



CUCINA SELECTION UK  
2011-2012

## Cucina Selection

This collection of built-in appliances has been specially selected for suitability in the contract market. These products combine elegance and advanced technology to provide style and reliability, satisfying the needs of the most discerning customer. With cooking, refrigeration, dishwashing, laundry, sinks and taps the Cucina Selection offers the contract buyer a complete kitchen portfolio.



The Cucina Selection is made up of a range of selected products designed specifically with the contract market in mind. The new range offers both existing products in addition to a number of exciting new models that further extend the range, providing an extensive and comprehensive choice for any new kitchen. Alternative and additional products to those in this collection are featured in the Smeg main range, which can be viewed at [www.smeguk.com](http://www.smeguk.com)



### Ovens

A squared design is featured throughout the Cucina single oven range and all stainless steel models are finger friendly. These ovens all have a generous 60 litre capacity, including an easy clean interior enamel finish, more effectively placed lamps and roof liners as standard. The SCP496 ovens have a Pyrolytic cleaning function which works by heating the inside of the oven to 500°C, at which temperature any grease stuck to the walls is simply burnt off. SC485 models include a cleaning function called Vapor clean, designed to make oven cleaning a simple task.

In addition to the single ovens there are double ovens for both in column and under worktop installation, a built-in microwave oven with grill, and a 90cm dual fuel stainless steel range cooker with two ovens. Double ovens and the range cooker have been renewed with increased cavities, and the DOSC54X has an impressive **68 litre maxi plus** main oven.



### Hobs

Enabling professional cooking, the SI3644B 60cm induction hob is a quick reacting appliance that also reduces energy consumption making this a superb choice for any kitchen. Providing further versatility of range options the SE32X 30cm electric hob is designed with two plates making it ideal for the more compact kitchen, whilst the 90cm SRV596-5 gas hob with black enamel pan stands and control knobs, is the widest hob in the Cucina selection allowing a much greater usable space for the consumer.



### Hoods

Intended to present the finest blend of elegance and functionality the Cucina hoods are composed of the highest grade stainless steel adding to their modern and contemporary design. The range includes the impressive KI90C-1 90cm Island hood which boasts an extraction rate of 660 m<sup>3</sup>/h. In addition to chimney hoods the Cucina selection also offers a range of integrated hoods including the telescopic KSET61, and canopy hood KSEG51, ideal for compact kitchens. All Cucina hoods can be operated in either a ducted or recirculation mode.



### Refrigeration

The majority of Cucina refrigeration models now achieve an A+ energy rating for energy efficiency. This selection offers a number of in-column and under worktop refrigeration products, presenting the consumer with plenty of choice. These integrated appliances discreetly merge into a kitchen, creating a simple and chic appearance.

New to the 2011-2012 Cucina brochure are two freestanding American side by side refrigerator-freezers featuring a dispenser for cold water and ice, either crushed or cubed. Both models are completely frost free and the SS55PTLH1 features a home bar, where bottles and cans can be stored.

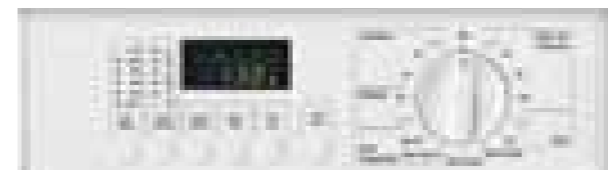

A series of special programmes and functions have been added to traditional programmes to provide the best washing care. Programmes can be customised by selecting various options such as temperature and spin speed, that make doing the laundry easier and more efficient.



### Dishwashers

The DI607C is a fully integrated 7-place dishwasher with an ergonomic compact horizontal design. This appliance has a variety of options for installation; in-column, under the counter, in suspended kitchen furniture, and into a standard 60cm aperture. The DDC6 and DIC6 feature a new hydraulic system that provides a reduction in water consumption, whilst the DIC4 is a triple A rated fully integrated 45cm model. All 60cm models within the Cucina range feature the Orbital wash system, which distributes water evenly throughout the cavity, ensuring an excellent wash quality and a greatly reduced noise level.

### Laundry

All laundry products in the Cucina selection feature large load capacities. The integrated washing machine model has an ample load capacity of 7kg whilst the washer dryer models have a wash load capacity of either 6kg for the integrated model or 7kg for the freestanding model.

### Sinks & Taps

Cucina sinks are manufactured in high grade stainless steel with an impressive bowl depth of 180mm. They are reversible, and are available in single bowl single drainer, or one and a half bowl single drainer versions. Cucina taps are produced with a sleek chrome finish in either a single lever or dual flow mixer tap design to perfectly harmonize with Smeg sinks. A variety of sink accessories in the main range can also be purchased to complement the Cucina sinks.

**DOSC54X**

60CM ELECTRIC MULTIFUNCTION DOUBLE OVEN, FINGER-FRIENDLY ST/STEEL ENERGY EFFICIENCY CLASS AA



Energy rating A  
4 functions lower main oven



Electronic clock/programmer  
Tangential cooling system  
Closed door grilling  
Removable inner door glasses  
5 cooking levels  
Easy clean enamel interior  
Oven capacity: gross - 79 litres, net - 68 litres  
Forced air convection: 0.79kW/h

Energy rating A  
4 functions upper auxiliary oven

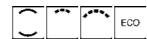

Variable grill  
Air cooling system  
Closed door grilling  
Removable inner door glasses  
3 cooking levels  
Easy clean enamel interior  
Oven capacity: gross - 41 litres, net - 33 litres  
Conventional: 0.59kW/h

Nominal power: 4.60 kW  
30 Amp power supply required

STANDARD ACCESSORIES:  
2 x Extra deep tray  
2 x Chrome shelf  
2 x Grill mesh  
Roof liner for auxiliary oven



OPTIONAL EXTRAS  
Pair of fully extractable telescopic guides GTIT  
Pair of partially extractable telescopic guides GT1P  
Pizza Shovel PALPZ  
Pizza Stone PRTX  
Stay clean liners (for main oven) PC68

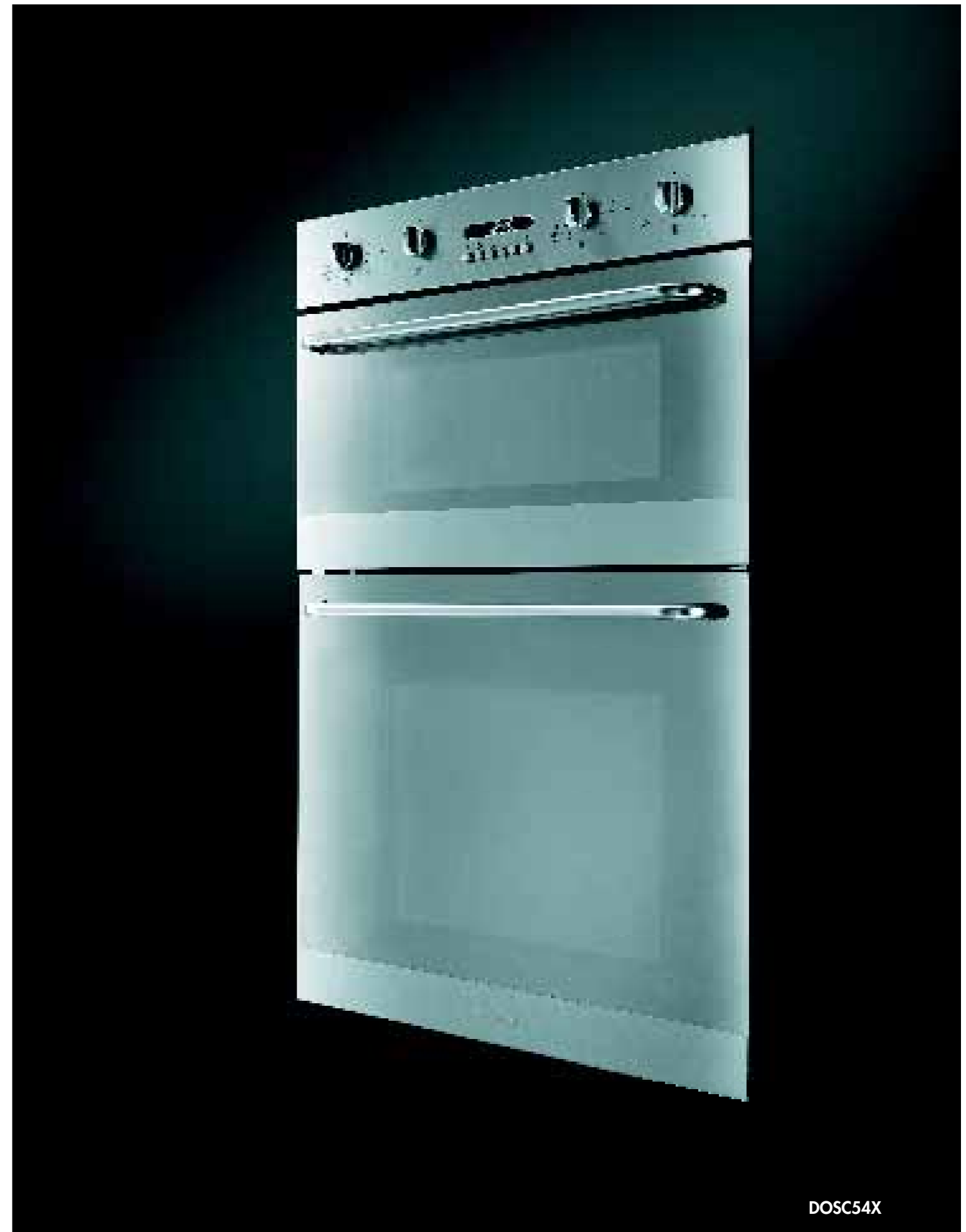
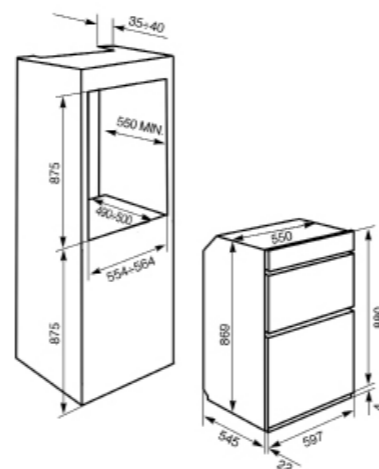

DOSC54X

**DUSC54X**

60CM DOUBLE UNDER COUNTER ELECTRIC MULTIFUNCTION OVEN, FINGER-FRIENDLY ST/STEEL ENERGY EFFICIENCY CLASS AA



Energy rating A  
4 functions lower main oven



Electronic clock/programmer  
Tangential cooling system  
Closed door grilling  
4 cooking levels  
Easy clean enamel interior  
Removable inner door glasses  
Oven capacity: gross - 70 litres, net - 60 litres  
Forced air convection: 0.79 kW/h

Energy rating A  
4 functions upper auxiliary oven

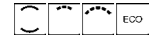

Variable grill  
Air cooling system  
Closed door grilling  
3 cooking levels  
Easy clean enamel interior  
Removable inner door glasses  
Oven capacity: gross - 41 litres, net - 33 litres  
Conventional: 0.59kW/h

Nominal power: 5.50 kW  
30 Amp power supply required

STANDARD ACCESSORIES:  
2 x Extra deep tray  
2 x Grill mesh  
2 x Chrome shelf  
Stay clean liners for main oven  
Roof liner for auxiliary oven

OPTIONAL EXTRAS  
Pair of fully extractable telescopic guides **GTIT**  
Pair of partially extractable telescopic guides **GT1P**  
Pizza Shovel **PALPZ**  
Pizza Stone **PRTX**



**FME20EX3**

MICROWAVE OVEN, FINGER-FRIENDLY STAINLESS STEEL



5 power levels  
Microwave output power 850W  
Quartz grill (1.0kW)  
Oven capacity: 20 litres

Dimensions without frame:  
340mm D x 485mm W x 320mm H

Nominal power: 2.75kW  
Kit for build-in installation included



MICROWAVE

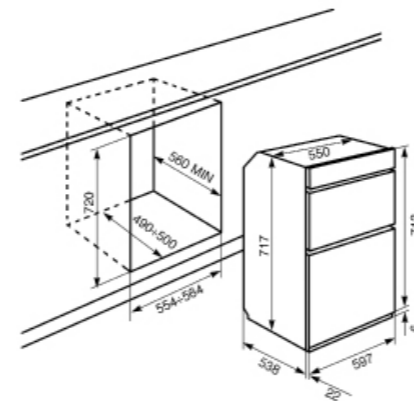

**DUSC54X** NB: Due to the restricted space remaining beneath the work surface above this oven unit, care must be taken when selecting a hob to ensure it will fit

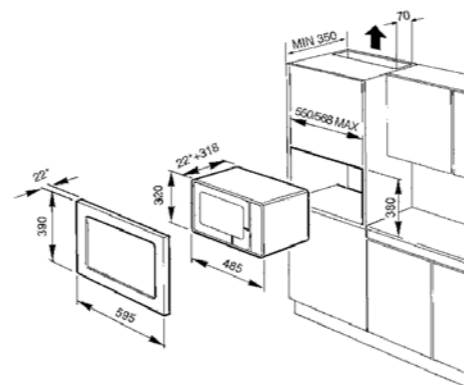

**FME20EX3**



**DUSC54X**

**SCP496X-8**

60CM PYROLITIC MULTIFUNCTION OVEN,  
FINGER FRIENDLY ST/STEEL  
ENERGY EFFICIENCY CLASS A



8 Functions



- Electronic programmer
- Tangential cooling system
- Closed door grilling
- Quadruple glazed removable door
- Delay timer
- Minute minder
- Easy clean enamel interior
- 4 cooking levels
- Removable inner door glass
- Pyrolitic cleaning from 1.5h to 3h**
- ECO pyroclean 1.5h
- Rapid pre-heating

Oven capacity: gross - 68 litres, net - 60 litres  
Forced air convection: 0.89 kW/h  
Conventional: 0.71 kW/h  
Nominal power: 3.00kW  
**13 Amp power supply required**

STANDARD ACCESSORIES:

- Roasting/grill pan
- Grill mesh
- Chrome shelf
- Roof liner

OPTIONAL EXTRAS:

- Pair of fully extractable telescopic guides **GT1T**
- Pair of partially extractable telescopic guides **GT1P**
- Pizza stone with handles **PRTX**
- Folding pizza shovel **PALPZ**

MODELS AVAILABLE

- St/steel **SCP496X-8**
- Black **SCP496N-8**

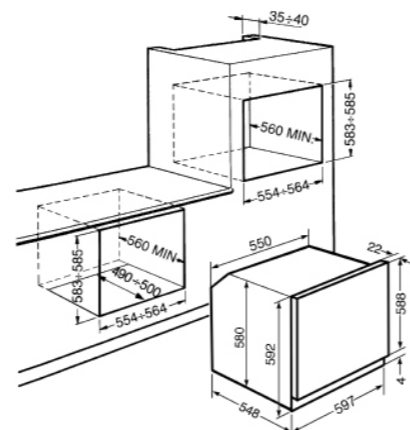

**SCP496X-8**

**SC485X-8**

60CM MULTIFUNCTION OVEN,  
FINGER FRIENDLY ST/STEEL  
ENERGY EFFICIENCY CLASS A



8 functions



- Full width grill
- Electronic clock/timer
- Tangential cooling system
- Closed door grilling
- Easy clean enamel interior
- 4 cooking levels
- Removable inner door glass
- Vapor clean programme

Oven capacity: gross - 70 litres, net - 60 litres  
Forced air convection: 0.79 kW/h  
Conventional: 0.91 kW/h  
Nominal power: 3.00 kW  
**13 Amp power required**

STANDARD ACCESSORIES:

- Roasting/grill pan
- Chrome shelf
- Grill mesh
- Roof liner

OPTIONAL EXTRAS:

- Pair of fully extractable telescopic guides
- Pair of partially extractable telescopic guides
- Stay clean liners
- Pizza stone with handles
- Folding pizza shovel

GT1T

GT1P

PC60

PRTX

PALPZ



**SC485N-8**

60CM MULTIFUNCTION OVEN,  
BLACK  
ENERGY EFFICIENCY CLASS A



Specification is the same as SC485X-8, but in black.

**SC436X-8**

60CM FAN OVEN,  
FINGER FRIENDLY ST/STEEL  
ENERGY EFFICIENCY CLASS A



6 functions



- Full or half width grill
- Fan with grill
- Closed door grilling
- Minute minder with automatic switch off
- Tangential cooling system
- Easy clean enamel interior
- 4 cooking levels
- Removable inner door glass

Oven capacity: gross - 68 litres, net - 60 litres  
Forced air convection: 0.79 kW/h  
Nominal power: 3.00 kW  
**13 Amp power required**

STANDARD ACCESSORIES:

- Roasting/grill pan
- Chrome shelf
- Grill mesh
- Roof liner

OPTIONAL EXTRAS:

- Pizza stone with handles
- Folding pizza shovel

PRTX  
PALPZ

MODELS AVAILABLE

- St/steel SC436X-8
- Black SC436N-8

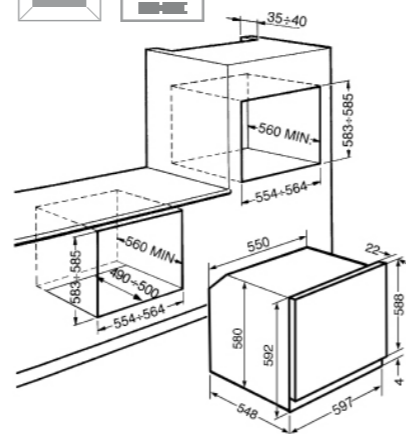

SC436N-8

**SRV596-5**

90CM GAS HOB, ST/STEEL



5 burners  
 Rear left: 3.10 kW  
 Front left: 1.05 kW  
 Centre: Ultra-rapid 3-way burner: 5.00 kW (3.90 + 1.10kW)  
 Rear right: 1.65 kW  
 Front right: 1.65 kW

St/Steel base  
 Silver controls  
 Enamelled pan stands  
 Black burner caps

Automatic electronic ignition  
 Safety valves  
 Adaptable for LPG

Nominal power: 11.55 kW  
 Total connected load: < 1.00 kW

**SE706S3**

70CM GAS HOB, ST/STEEL



5 burners  
 Rear left: 2.55 kW  
 Front left: 1.05 kW  
 Centre: 3.90 kW  
 Rear right: 1.65 kW  
 Front right: 1.65 kW

St/Steel base  
 Black controls  
 Enamelled pan stands  
 Black burner caps

Automatic electronic ignition  
 Safety valves  
 Adaptable for LPG

Nominal power: 11.00 kW  
 Total connected load: < 1.0 kW

MODELS AVAILABLE  
 St/steel with black pan stands  
 and black controls **SE706S3**  
 St/steel with black pan stands  
 and st/steel controls **SE706SX3**

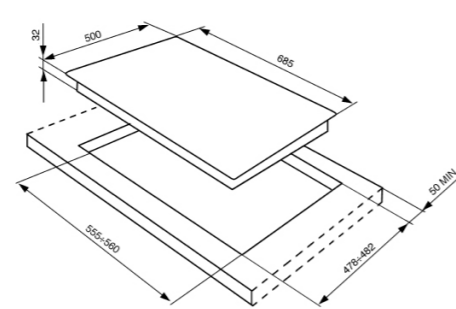
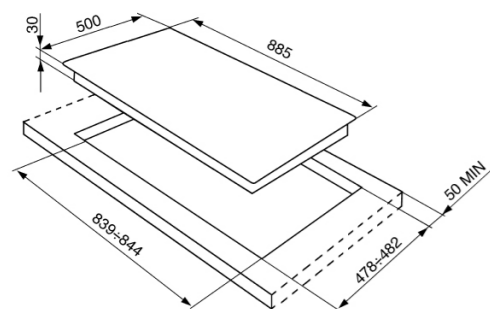

**SV564-3**

60CM GAS HOB, ST/STEEL



4 burners  
 Rear left: 3.10kW  
 Front left: 1.05kW  
 Rear right: 1.65kW  
 Front right: 1.65kW

St/steel base  
 Silver controls  
 Enamelled pan stands  
 Black burner caps

Automatic electronic ignition  
 Safety valves  
 Adaptable for LPG

Nominal power: 7.55kW  
 Total connected load: c.0.54 kW

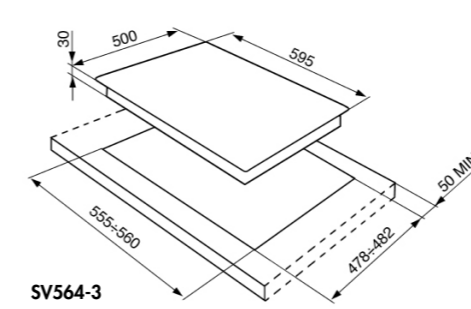

**SV564-3**

**SER64SNX3**

60CM GAS HOB, ST/STEEL



4 burners  
 Rear left: 1.65 kW  
 Front left: 4.05 kW Ultra-rapid triple  
 flame burner  
 Rear right: 1.65 kW  
 Front right: 1.05 kW

St/Steel base  
 St/Steel controls  
 Enamelled pan stands  
 Black burner caps

Automatic electronic ignition  
 Safety valves  
 Adaptable for LPG

Nominal power: 8.04 kW  
 Total connected load: c. 0.54 kW

MODELS AVAILABLE  
 St/steel with ultra rapid burner  
 and safety valves **SER64SNX3**  
 St/steel with safety valves **SE64SNX3**  
 Black with safety valves **SE64SNE3**

**SE64SNX3**

60CM GAS HOB, ST/STEEL



4 burners  
 Rear left: 1.65 kW  
 Front left: 3.10 kW  
 Rear right: 1.65 kW  
 Front right: 1.05 kW

St/steel base  
 St/steel controls  
 Enamelled pan stands  
 Black burner caps

Automatic electronic ignition  
 Safety valves  
 Adaptable for LPG

Nominal power: 7.55kW  
 Total connected load: c.0.54 kW

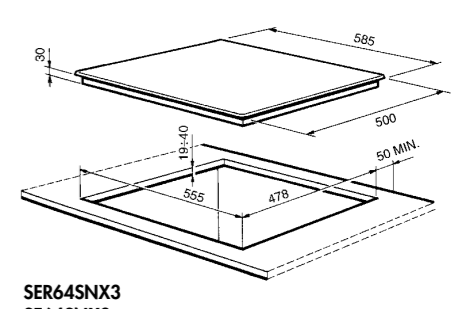

**SER64SNX3  
 SE64SNX3**

**SI3644B**

60CM TOUCH CONTROL INDUCTION HOB WITH ANGLED EDGE GLASS



4 full power induction zones  
 Front left: ø 210/100mm, 1.85kW – booster 2.3kW  
 Rear left: ø 180/100mm, 1.65kW – booster 2.3kW  
 Rear right: ø 210/100mm, 1.80kW – booster 2.3kW  
 Front right: ø 160/100mm, 1.25kW – booster 2.0kW

"Suprema" black ceramic glass  
 4 boosters  
 9 power levels  
 Electronic timer which can be used with all zones  
 Residual heat indicators  
 Automatic safety cut-out  
 Child safety lock

Nominal power 7.2 kW  
 30 Amp power supply required

NB: Only pans with a ferrrous (magnetic) base are suitable for induction hobs

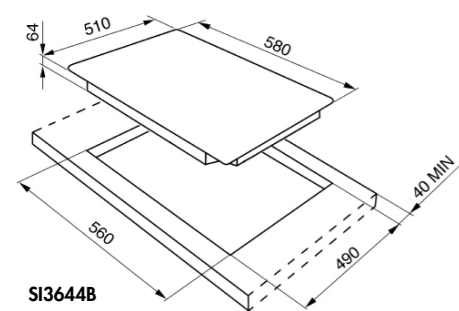

SI3644B

**SE2640TD2**

60CM TOUCH CONTROL CERAMIC HOB WITH STRAIGHT EDGE GLASS

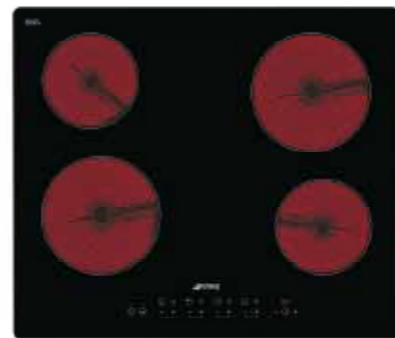

4 "High-light" radiant cooking zones  
 Rear left: ø 140mm, 1.20 kW  
 Front left: ø 180mm, 1.80 kW  
 Rear right: ø 180mm, 1.80 kW  
 Front right: ø 140mm, 1.20 kW

"Suprema" black ceramic glass  
 9 power levels  
 Independent timer  
 Residual heat indicators  
 Automatic safety cut-out  
 Child safety lock

Nominal power: 6.20 kW  
 30 Amp power supply required

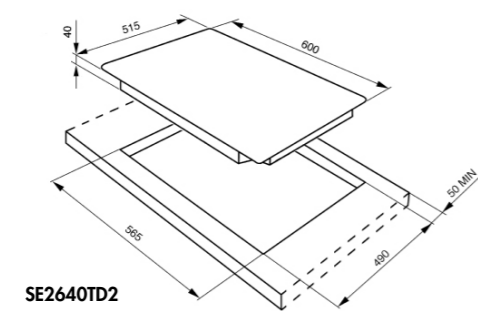

SE2640TD2

**SE660X1**

60CM CERAMIC HOB WITH ANGLED EDGE GLASS

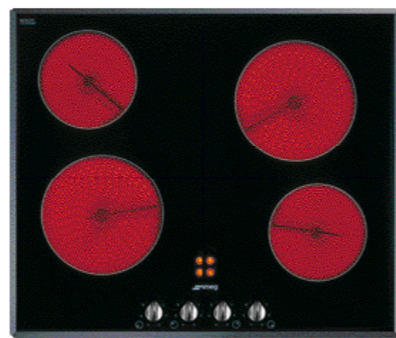

4 "High-light" radiant cooking zones  
 Rear left: ø 140mm, 1.20 kW  
 Front left: ø 180mm, 1.80 kW  
 Rear right: ø 180mm, 1.80 kW  
 Front right: ø 140mm, 1.20 kW

Front stainless steel controls to match Cucina ovens  
 "Suprema" black ceramic glass  
 Residual heat indicators  
 Automatic safety cut-out

Nominal power: 6.00kW  
 30 Amp power supply required

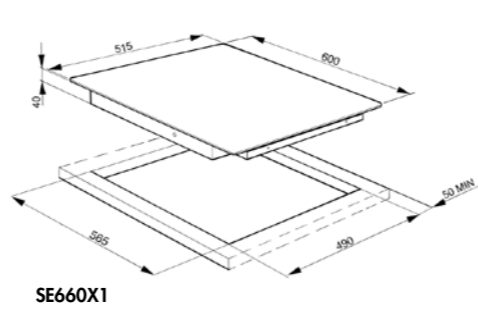

SE660X1



SE660X1

**SE32X**

30CM ELECTRIC HOB,  
ST/STEEL



2 plate electric hob  
Rear fast plate: ø 180mm,  
2.00 kW  
Front fast plate: ø 145mm,  
1.50 kW

Nominal power: 3.50 kW  
30 Amp power supply  
required

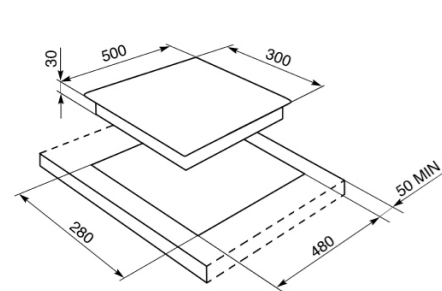

SE32X

**SE435X-1**

60CM ELECTRIC HOB, ST/STEEL



4 plate electric hob  
2 fast plates  
Rear left: ø 145mm, 1.50 kW  
Front left: ø 180mm, 1.50 kW  
Rear right: ø 180mm, 2.00 kW  
Front right: ø 145mm, 1.00 kW

Nominal power 6.00kW  
30 Amp power supply required

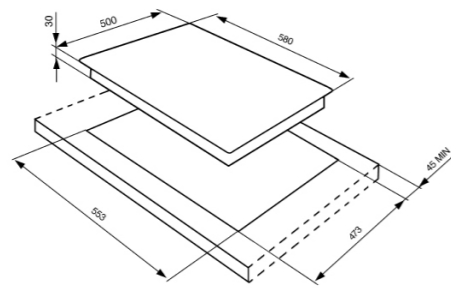

SE435X-1

**CC92MX8**

90CM COOKER WITH DOUBLE OVEN AND  
GAS HOB, ST/STEEL  
ENERGY EFFICIENCY CLASS AA



MAIN OVEN:  
Energy rating A  
7 functions



Oven capacity: gross - 70 litres, net - 60 litres  
Digital electronic clock/programmer  
Tangential cooling system  
Closed door grilling  
Easy clean enamel interior  
Vapor clean  
Conventional: 0.80kW/h  
Forced air convection: 0.69kW/h

AUXILIARY OVEN:  
Energy rating A  
4 functions



Oven capacity: gross - 35 litres, net - 27 litres  
Variable grill  
Closed door grilling  
Tangential cooling system  
Easy clean enamel interior  
Conventional: 0.59kW/h

HOB:  
5 burner gas hob  
Rear left: 1.80kW  
Front left: Rapid 3.0kW  
Centre: Ultra rapid 3.5kW  
Rear right: 1.75kW  
Front right: 1.00 kW  
Automatic ignition  
Safety valves  
Enamelled pan stands  
Adaptable for LPG

Silver feet and black plinth provided

Nominal power: 4.30 kW  
30 Amp power supply required



STANDARD ACCESSORIES:  
MAIN OVEN:  
Extra deep tray  
Grill mesh  
Chrome shelf

AUXILIARY OVEN:  
Roasting/grill pan  
Grill mesh  
Chrome shelf

OPTIONAL EXTRAS  
Splashback  
Pizza stone  
Pizza shovel  
Wok support  
Teppanyaki grill plate

**KIT90X**  
**PRTX**  
**PALPZ**  
**WOKGHU**  
**TBX6090**

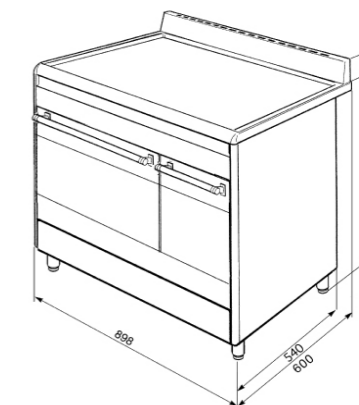

NB: Height with plinth installed is fixed at 900mm

**KI90C-1**

90CM ISLAND HOOD, ST/STEEL



1 high performance motor 250W  
 3 speeds  
 4 halogen lights (20W each)  
 3 aluminium grease filters  
 Internal re-circulation possible  
 Vent outlet ø 150mm  
 Nominal power: 330W

Speed	Extraction rate IEC 61591 (m³/h)	Noise Level IEC 60704-2-13 dB(A)
I	260	45
II	405	56
III	660	68

OPTIONAL EXTRAS:  
 Charcoal filter           KITFC155  
 Simple ducting kit        SP150  
 Comprehensive ducting kit   SP150FLAT

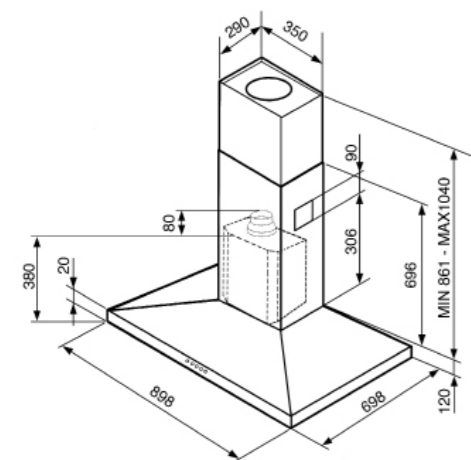

**KSE91X**

90CM CHIMNEY HOOD, ST/STEEL



1 high performance motor, 115W  
 3 speeds  
 3 grease filters (dishwasher safe)  
 Upper section glass aesthetic  
 Internal re-circulation possible  
 Vent outlet: ø 150mm  
 Nominal power: 195W

Speed	Extraction rate IEC 61591 (m³/h)	Noise Level IEC 60704-2-13 dB(A)
I	240	44
II	340	52
III	437	54

OPTIONAL EXTRAS:  
 Charcoal filter           KIT1C  
 Simple ducting kit        SP150  
 Comprehensive ducting kit   SP150FLAT

MODELS AVAILABLE  
 90cm width                KSE91X  
 70cm width (2 filters)   KSE71X  
 60cm width (2 filters)   KSE61X

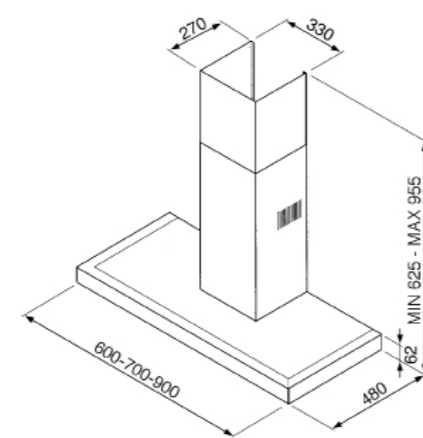

**KSE91X**

**KSED92X**

90CM CHIMNEY HOOD, ST/STEEL



1 high performance motor, 195W  
3 speeds  
3 metal grease filters  
Internal re-circulation possible  
Vent outlet: ø 120mm  
Nominal power 275W

Speed	Extraction rate IEC 61591 (m³/h)	Noise Level IEC 60704-2-13 dB(A)
I	255	45
II	280	49
III	350	58

OPTIONAL EXTRAS:  
Charcoal filter **FLT2**  
Simple ducting kit **SP215**  
Comprehensive ducting kit **SP217**

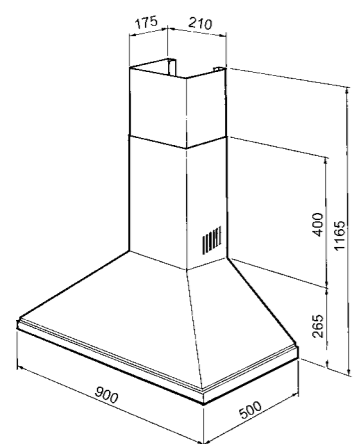

**KSED62X**

60CM CHIMNEY HOOD, ST/STEEL



1 high performance motor, 195W  
3 speeds  
2 metal grease filters  
Internal re-circulation possible  
Vent outlet: ø 120mm  
Nominal power 275W

Speed	Extraction rate IEC 61591 (m³/h)	Noise Level IEC 60704-2-13 dB(A)
I	255	45
II	280	49
III	350	58

OPTIONAL EXTRAS:  
Charcoal filter **FLT2**  
Simple ducting kit **SP215**  
Comprehensive ducting kit **SP217**

MODELS AVAILABLE  
60cm width **KSED62X**  
70cm width **KSED72X**

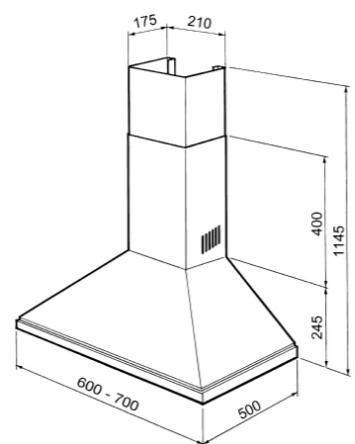

**KSET61**

60CM TELESCOPIC HOOD, ST/STEEL EFFECT



1 high performance motor, 160W  
2 speeds  
2 lights (40W each)  
2 metal grease filters  
Internal recirculation possible  
Vent outlet ø 120mm  
Nominal power 240W

Speed	Extraction rate IEC 61591 (m³/h)	Noise Level IEC 60704-2-13 dB(A)
I	233	45
II	332	54

OPTIONAL EXTRAS:  
Charcoal filters **KITC3C x 2**  
Simple ducting kit **SP215**  
Comprehensive ducting kit **SP217**

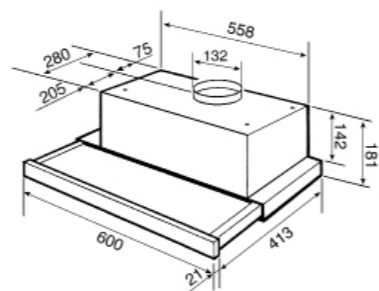

**KSEI62**

60CM INTEGRATED HOOD



1 high performance motor, 150W  
3 speeds  
2 lights (40W each)  
1 metal grease filter  
Internal re-circulation possible  
Vent outlet ø 120mm  
Nominal power 230W

Speed	Extraction rate IEC 61591 (m³/h)	Noise Level IEC 60704-2-13 dB(A)
I	135	54
II	175	61
III	270	65

OPTIONAL EXTRAS:  
Charcoal filter **KITFC31**  
Simple ducting kit **SP215**  
Comprehensive ducting kit **SP217**

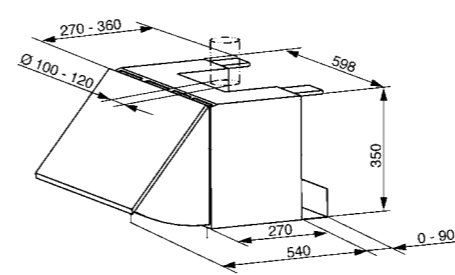

**KSEC61X**

60CM STANDARD HOOD



1 high performance motor, 125W  
3 speeds  
2 metal grease filters  
Internal re-circulation possible  
Vent outlet ø 120mm  
Nominal power 205W

Speed	Extraction rate IEC 61591 (m³/h)	Noise Level IEC 60704-2-13 dB(A)
I	116	39
II	142	43
III	240	56

OPTIONAL EXTRAS:  
Charcoal filter **KITC2R**  
Simple ducting kit **SP215**  
Comprehensive ducting kit **SP217**

MODELS AVAILABLE  
St/steel **KSEC61X**  
Black **KSEC61NE**

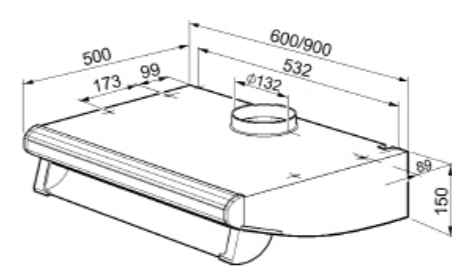

**KSEG51**

52CM CANOPY HOOD



1 high performance motor, 80W  
3 speeds  
2 lights (40W each)  
1 metal grease filter  
Internal re-circulation possible  
Vent outlet ø 120mm  
Nominal power 160W

Speed	Extraction rate IEC 61591 (m³/h)	Noise Level IEC 60704-2-13 dB(A)
I	140	49
II	160	52
III	210	56

OPTIONAL EXTRAS:  
Charcoal filter **KITFC142**  
Simple ducting kit **SP215**  
Comprehensive ducting kit **SP217**

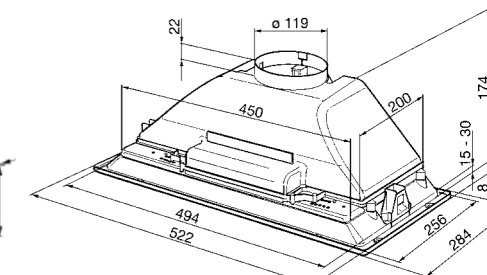

**SS55PTLH1**

AMERICAN SIDE BY SIDE REFRIGERATOR-FREEZER WITH SOFT-TOUCH HOME BAR, ST/STEEL EFFECT  
ENERGY EFFICIENCY CLASS A+



Gross capacity: 600 litres  
LCD display and soft-touch control panel  
Ice and water dispenser  
Internal water filter  
**Soft-touch home bar**  
Holiday function  
Child lock function

REFRIGERATOR:  
Fresh food capacity: 365 litres  
"Extra Fresh" zone with soft-touch control  
2 drawers with humidity control  
Chrome wine rack  
4 temperature sensors  
Comprehensive door storage

FREEZER: **★★★★**  
Frozen food capacity: 173 litres  
**Completely frost free**  
Fast freeze  
2 drawers  
4 glass shelves  
4 temperature sensors  
Comprehensive door storage

Energy efficiency class: A+  
Energy consumption: 440 kW/h per year  
Climatic class: N  
Freezing capacity: 12kg/24h  
Thaw time: 17 h

Nominal power: 0.9kW



**SS55PTE1**

AMERICAN SIDE BY SIDE REFRIGERATOR-FREEZER, ST/STEEL EFFECT  
ENERGY EFFICIENCY CLASS A+



Gross capacity: 600 litres  
LED display and soft-touch control panel  
Ice and water dispenser  
Internal water filter  
Holiday function  
Child lock function

REFRIGERATOR:  
Fresh food capacity: 365 litres  
3 drawers with humidity control  
Chrome wine rack  
4 temperature sensors  
Comprehensive door storage

FREEZER: **★★★★**  
Frozen food capacity: 173 litres  
**Completely frost free**  
Fast freeze  
2 drawers  
4 glass shelves  
4 temperature sensors  
Comprehensive door storage

Energy efficiency class: A+  
Energy consumption: 440 kW/h per year  
Climatic class: N  
Freezing capacity: 12kg/24h  
Thaw time: 17 h

Nominal power: 0.9kW

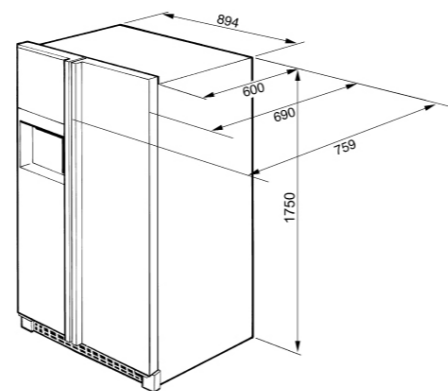

**CR325APL1**

INTEGRATED IN COLUMN COMBINED REFRIGERATOR & FREEZER  
ENERGY EFFICIENCY CLASS A+



Gross capacity: 278 litres  
Tropicalized compressor  
Reversible doors  
Sliding rail fitting  
Adjustable thermostat

REFRIGERATOR:  
Fresh food capacity: 201 litres  
Automatic defrost  
4 adjustable glass shelves  
Glass fruit and vegetable cover  
2 fruit and vegetable containers  
Comprehensive door storage

FREEZER: **★★★★**  
Frozen capacity: 72 litres  
3 drawers

Energy efficiency class: A+  
Energy consumption: 292 kW/h per year  
Climatic class: SN-ST  
Freezing capacity: 6kg/24h  
Thaw time: 19 h

Nominal Power: 1.4kW

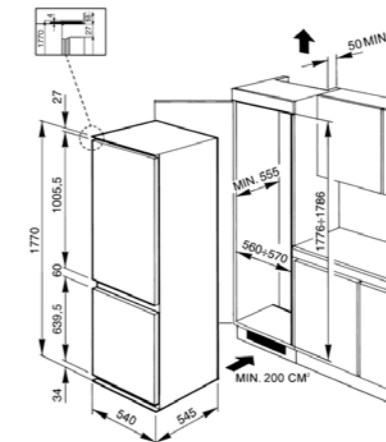

**CR5050AP**

INTEGRATED IN COLUMN COMBINED REFRIGERATOR & FREEZER  
ENERGY EFFICIENCY CLASS A+



Gross capacity: 277 litres  
Reversible doors  
Sliding rail fitting

REFRIGERATOR:  
Fresh food capacity: 162 litres  
3 adjustable glass shelves  
Glass fruit and vegetable cover  
2 fruit and vegetable containers  
Comprehensive door storage

FREEZER: **★★★★**  
Frozen food capacity: 95 litres  
4 drawers  
Ice cube tray

Energy efficiency class: A+  
Energy consumption: 285 kW/h per year  
Climatic class: SN-ST  
Freezing capacity: 4.5kg/24h  
Thaw time: 19 h

Nominal power: 1.4kW

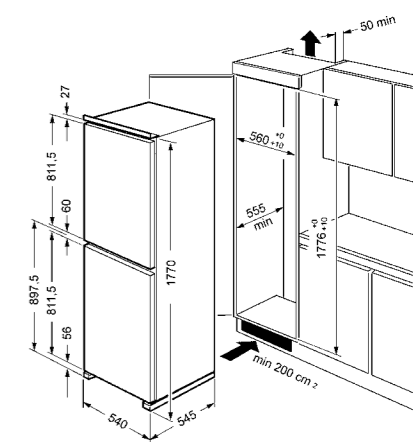

**UKFL164AP**

INTEGRATED IN COLUMN LARDER REFRIGERATOR  
ENERGY EFFICIENCY CLASS A+



Gross capacity: 146 litres  
Reversible door

REFRIGERATOR  
Fresh food capacity: 145 litres  
Automatic defrost  
3 adjustable glass shelves  
1 fixed glass shelf  
2 fruit & vegetable containers  
Comprehensive door storage

Possible combination with UKVI144AP freezer

Energy efficiency class: A+  
Energy consumption: 120 kW/h per year  
Climatic class: ST  
Nominal power: 0.50kW



**UKFL167AP**

IN COLUMN REFRIGERATOR WITH ICE-BOX  
ENERGY EFFICIENCY CLASS A+



Gross capacity: 131 litres  
Reversible door

REFRIGERATOR  
Fresh food capacity: 114 litres  
Automatic defrost  
2 adjustable glass shelves  
1 fixed glass shelf  
2 vegetable containers  
Comprehensive door storage

FREEZER  
Frozen food capacity: 17 litres  
Ice cube tray

Energy efficiency class: A+  
Energy consumption: 175 kW/h per year  
Climatic class: ST  
Freezing capacity: 2kg/24h  
Thaw time: 12h  
Nominal power: 0.80kW



**UKVI144AP**

IN COLUMN FREEZER  
ENERGY EFFICIENCY CLASS A+



Gross capacity: 103 litres  
Reversible door

FREEZER  
Frozen food capacity: 86 litres  
4 drawers  
Fast freezing function and button  
Acoustic alarm

Possible combination with UKFL164AP larder Refrigerator

Energy efficiency class: A+  
Energy consumption: 186kW/h per year  
Climatic class: N-ST  
Freezing capacity: 9kg/24h  
Thaw time: 15h  
Nominal power: 0.80kW

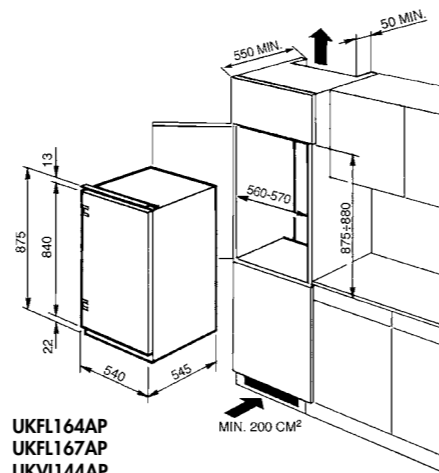

**LF1700C**

INTEGRATED UNDERWORKTOP LARDER REFRIGERATOR  
ENERGY EFFICIENCY CLASS A



Gross capacity: 144 litres  
Reversible door

REFRIGERATOR  
Fresh food capacity: 143 litres  
Automatic defrost  
3 adjustable glass shelves  
Fruit and vegetable compartment  
Further door storage

Energy efficiency class: A  
Energy consumption: 139 kW/h per year  
Climatic class: SN  
Nominal power: 0.70kW

**FR1650C**

INTEGRATED UNDERWORKTOP FREEZER  
ENERGY EFFICIENCY CLASS A



Gross capacity: 96 litres  
Reversible door

FREEZER  
Frozen food capacity: 86 litres  
3 Storage drawers  
Fast freezing function

Energy efficiency class: A  
Energy consumption: 204kW/h per year  
Climatic class: SN  
Freezing capacity: 8kg/24h  
Thaw time: 17 hours  
Nominal power: 0.90kW



**RF1500C**

INTEGRATED UNDERWORKTOP REFRIGERATOR WITH ICE-BOX  
ENERGY EFFICIENCY CLASS A



Gross capacity: 130 litres  
Reversible door

REFRIGERATOR  
Fresh food capacity: 105 litres  
Automatic defrost  
2 adjustable glass shelves  
Fruit and vegetable storage compartment

FREEZER  
Frozen food capacity: 21 litres  
Ice cube tray

Energy efficiency class: A  
Energy consumption: 208kW/h per year  
Climatic class: ST  
Nominal power: 0.80kW

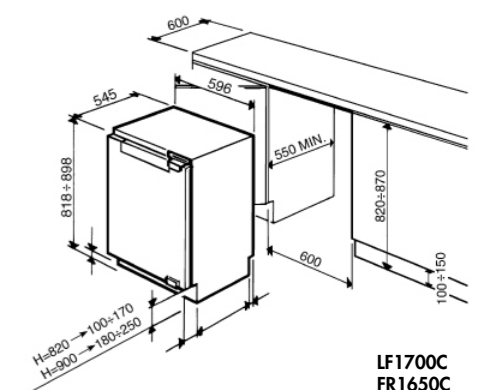

**DDC6**

60CM DRAWER LINE DISHWASHER,  
FINGER-FRIENDLY ST/STEEL  
ENERGY EFFICIENCY CLASS AAA



12 place settings  
5 programmes, inc. rapid 27 min wash  
4 temperatures (45° 55° 65° 70°)

3 Buttons:  
On/Off  
Programme selection  
Start/Pause

Lights:  
On/Off  
Programme Selection

Orbital spray system  
Partial Acquastop  
Concealed heating element  
Maximum plate diameter: 30cm  
Average wash time approximately 100 mins  
Adjustable water softener  
Self balancing door hinges  
Graphite baskets

Eco programme EN50242  
Water: 12 litres  
Energy: 1.05kWh  
Energy efficiency: A  
Washing performance: A  
Drying performance: A  
Noise level 50 dB (A) re 1 pW  
Nominal power: 1.9kW

Maximum furniture door weight 7.5kg  
Minimum furniture door weight 2.5kg



**DIC6**

60CM FULLY INTEGRATED DISHWASHER  
ENERGY EFFICIENCY CLASS AAA



12 place settings  
5 programmes  
4 temperatures (45° 55° 65° 70°)

2 Buttons:  
On/Off  
Programme selection

Lights:  
Programme Selection

Orbital spray system  
Partial Acquastop  
Concealed heating element  
Maximum plate diameter: 30cm  
Average wash time approximately 100 mins  
Adjustable water softener  
Self balancing door hinges  
Graphite baskets

Eco programme EN50242  
Water: 12 litres  
Energy: 1.05kWh  
Energy efficiency: A  
Washing performance: A  
Drying performance: A  
Noise level 48 dB (A) re 1 pW  
Nominal power: 1.9kW

Maximum furniture door weight 7.5kg  
Minimum furniture door weight 2.5kg

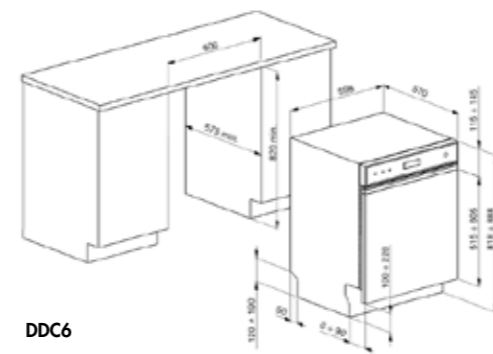

**DDC6**

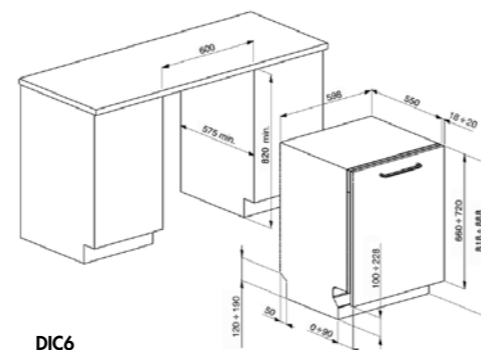

**DIC6**

**DI607C**

60CM FULLY INTEGRATED HORIZONTAL DISHWASHER  
ENERGY EFFICIENCY CLASS AAA



7 place settings  
10 programmes, inc. rapid power wash  
5 temperatures (38° 45° 55° 65° 70°)

5 Buttons:  
On/Off  
Programme selection  
Delay Timer 9h  
Selector for multi action tablets  
Additional programmes

Lights:  
Salt  
Rinse aid

Orbital spray system  
Total Acquastop  
Concealed heating element  
Maximum plate diameter: 32cm  
Average wash time approximately 100 mins  
Adjustable water softener  
Self balancing door hinges  
Graphite basket with anti-drip device  
St/steel filter

Eco programme EN50242  
Water: 10 litres  
Energy: 0.69kWh  
Energy efficiency: A  
Washing performance: A  
Drying performance: A  
Noise level 46 dB (A) re 1 pW  
Nominal power: 1.9kW

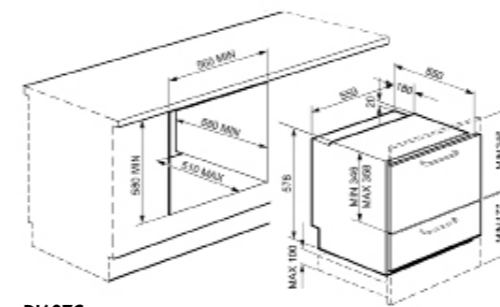

**DI607C**

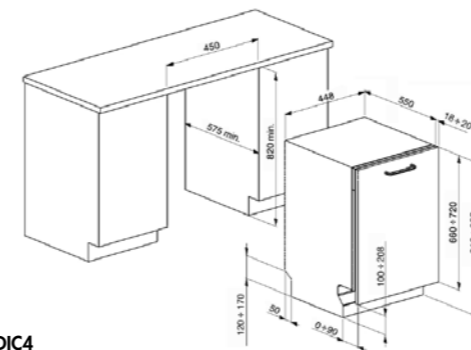

**DIC4**

**DIC4**

45CM FULLY INTEGRATED DISHWASHER  
ENERGY EFFICIENCY CLASS AAA



10 place settings  
5 programmes  
4 temperatures (45° 55° 65° 70°)

2 Buttons:  
On/Off  
Programme selection

Lights:  
Salt  
Rinse aid

Shuttle spray system  
Partial Acquastop with double hose  
Concealed heating elements  
Maximum plate diameter: 30cm  
Average wash time approximately 100 mins  
Adjustable water softener  
Self balancing door hinges  
Graphite baskets  
St/steel filter

Eco programme EN50242  
Water: 13 litres  
Energy: 1.01 kWh  
Energy efficiency: A  
Washing performance: A  
Drying performance: A  
Noise level 50 dB(A) re 1 pW  
Nominal power: 1.9kW

Maximum furniture door weight 7.5kg  
Minimum furniture door weight 2.5kg

NB: DIC4 was previously marketed as DI410C



**WDF12C7**

FREE-STANDING WASHER/DRYER, WHITE  
ENERGY EFFICIENCY CLASS BA



Electronic display includes 24h delay timer  
6 buttons: Start/pause, drying, confirm options, options selector, spin speed selector, temperature selector  
On/off & programme control  
Door opening release

Electronic display shows programme selected and progression

15 washing programmes including Special programmes; mix, shirts, gym, night, softener and **super fast 15 min.**  
Customised options; variable temperature, spin speed, option selector, and FlexiTime  
2 drying programmes  
Variable spin speed up to 1200rpm  
**Max washing capacity: 7Kg dry laundry**  
**Max drying capacity: 4Kg**  
Condenser drying  
St/steel drum and polypropylene tank  
Self clean detergent drawer  
Extra large 300mm porthole  
Automatic variable load

Consumption:  
For washing only: water: 47 litres, energy: 1.19kW/h  
For complete 7Kg wash + 2 sessions of 4Kg drying: water: 103 litres, energy: 5.44kW/h  
Nominal power: 2.00kW

Energy efficiency class: B  
Washing performance: A

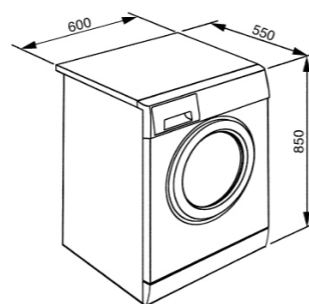

**WDI12C6**

FULLY INTEGRATED WASHER/DRYER  
ENERGY EFFICIENCY CLASS BA



Electronic display includes 24h delay timer  
6 buttons: Start/pause, drying, delay timer, confirm options, options selector, spin speed selector  
On/off & programme control  
Door opening release

Electronic display shows programme selected and progression

12 washing programmes including Special programmes; mixed fabrics, super fast 15 min.  
Customised options; variable temperature, spin speed, and option selector  
2 drying programmes  
Variable spin speed up to 1200rpm  
**Max washing capacity: 6Kg dry laundry**  
**Max drying capacity: 4Kg**  
Condenser drying  
St/steel drum and polypropylene tank  
Self clean detergent drawer  
Extra large 300mm porthole  
Automatic variable load  
Total Acquastop

Consumption:  
For washing only: water: 47 litres, energy: 1.02kW/h  
For complete 6Kg wash + 2 sessions of 4Kg drying: Water 90 litres, energy: 4.85kW/h  
Nominal power: 2.00kW

Energy efficiency class: B  
Washing performance: A

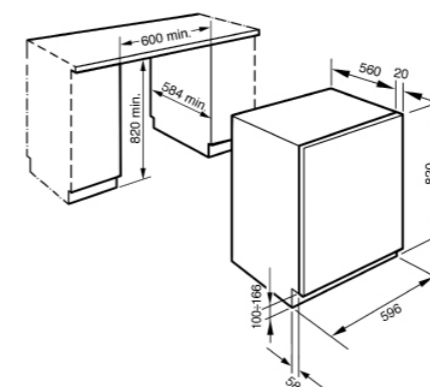

**WMI12C7**

FULLY INTEGRATED WASHING MACHINE  
ENERGY EFFICIENCY CLASS AAB



Electronic display includes 24h delay timer  
6 buttons: start/pause, child lock, delay timer, confirm options, option selector, spin speed  
On/off & Programme control  
Door opening release

Electronic display shows programme selected and progression

15 washing programmes including Special programmes; mixed 30°C and super fast 15 min  
Customised options; variable temperature, spin speed, and option Selector  
Variable spin speed up to 1200rpm  
**Max 7Kg of dry laundry**  
St/steel drum and polypropylene tank  
Self clean detergent drawer  
Extra large 300mm porthole  
Automatic variable load  
Total Acquastop

Consumption:  
Water: 47 litres  
Energy: 1.19kW/h  
Nominal power: 2.00kW

Energy efficiency class: A  
Washing performance: A  
Spin drying performance: B

**CUR150**

1.5 BOWL SINGLE DRAINER REVERSIBLE ST/STEEL INSET SINK



1.5 bowl single drainer inset sink  
 Bowl depth: 1x190mm 1x130mm  
 Bowl width: 1x340mm 1x 165mm  
 Drain: 2x3.5"

STANDARD ACCESSORIES:  
 Overflow  
 Drain  
 Gaskets  
 Fixing Clips  
 Dishwasher Drain Tap

**CUR100**

SINGLE BOWL SINGLE DRAINER REVERSIBLE ST/STEEL INSET SINK



Single bowl single drainer inset sink  
 Bowl depth: 1x190mm  
 Bowl width: 1x340mm  
 Drain: 2x3.5"

STANDARD ACCESSORIES:  
 Overflow  
 Drain  
 Gaskets  
 Fixing Clips  
 Dishwasher Drain Tap

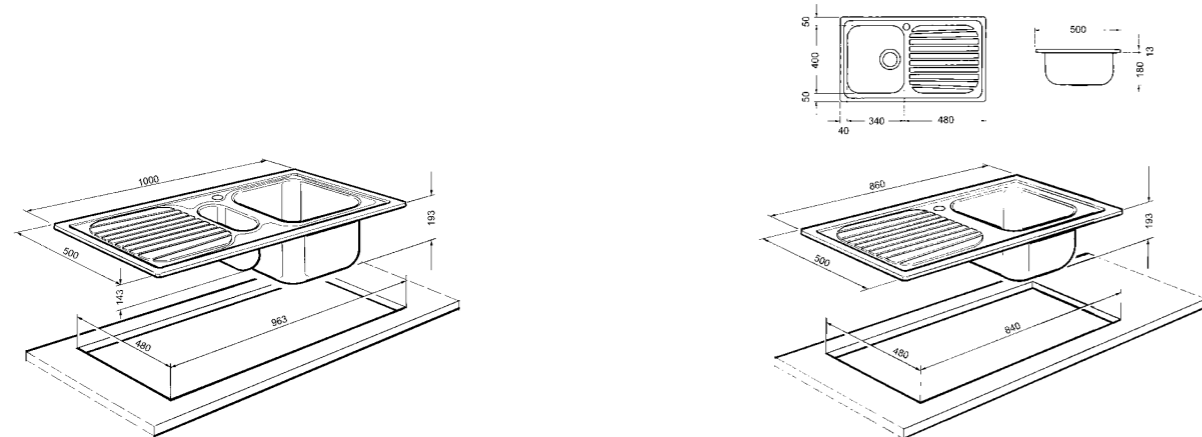

**PALERMO**

SINGLE LEVER MIXER TAP



Single lever mixer  
 Chrome finish  
 Swivel spout  
 Aerator  
 Ceramic disc cartridge  
 Braided stainless steel connection hoses

**RIMINI-2**

DUAL FLOW MIXER TAP



Dual flow mixer  
 Chrome finish  
 Swivel spout  
 Spout with anti-splash  
 Quarter turn ceramic disc valve  
 Copper connection tails

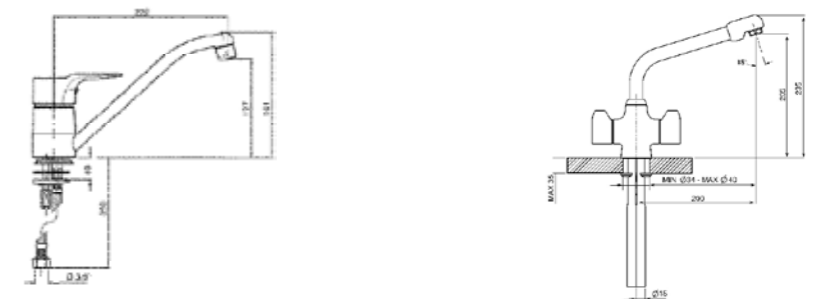

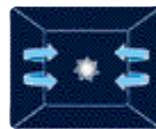

 **UPPER AND LOWER ELEMENT ONLY:**  
A traditional cooking method best suited for single items located in the centre of the oven. The top of the oven will always be hottest. Ideal for roast, fruit cakes, bread etc.

 **FAN WITH LOWER ELEMENT:**  
This combination completes cooking more quickly of foods that are ready on the surface, but require more cooking inside, without further

 **DEFROST:**  
Both symbols refer to the same function. The circulation of enables quicker thawing of frozen food, without the use of any heat. Ideal for use prior to cooking of ready-made dishes, or cream filled products etc.

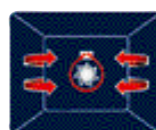
 **LOWER HEATING ELEMENT ONLY:**  
Ideal for foods that require extra base temperature without browning, e.g. pastry dishes, pizza. Also suitable for slow cooking of stews and casseroles.

 **CIRCLAIRE:**  
The combination of the fan and circular element around it gives a hot air cooking method. This provides many benefits including no preheat if cook time is more than 20 minutes, no flavour transfer when cooking different foods at the same time, less energy, and shorter cook times. Good for all types of food.

 **FAN:**  
As above but with thermostat set a '0'.

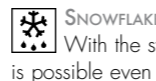
 **SNOWFLAKE:**  
With the switch on this symbol, no heating is possible even if the thermostat is turned.

 **GRILL ELEMENT/HALF GRILL:**  
For rapid cooking and browning of foods. Best results can be obtained by using the top shelf for small items, the lower shelves for larger ones, such as chops or sausages. For half grill heat is generated only at the centre of the element, so is ideal for smaller quantities.

 **CIRCLAIRE WITH UPPER AND LOWER ELEMENTS:**  
The use of the fan with both elements allows food to be cooked quickly and effectively, ideal for large joints that require thorough cooking. It offers a similar result to rotisserie, moving the heat around the food, instead of moving the food itself, enabling any size or shape to be cooked.

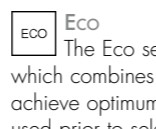
 **ECO**  
The Eco setting is a fast preheat function, which combines grill, fan and lower element to achieve optimum energy efficiency. Only to be used prior to selecting the main cook function.

 **FAN WITH GRILL ELEMENT:**  
The fan reduces the fierce heat from the grill, providing an excellent method of grilling various foods, chops, steaks, sausages etc. giving even browning and heat distribution, without drying out the food. The top two levels recommended for use, and the lower part of the oven can be used to keep items warm at the same time, an excellent facility when cooking a grilled breakfast. Half grill (centre portion only) is ideal for small quantities of food.

 **FAN WITH UPPER AND LOWER ELEMENTS:**  
The elements combined with the fan aim to provide more uniform heat, a similar method to conventional cooking, so pre-heat is required. Most suitable for items requiring slow cooking methods.

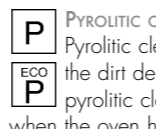
 **PYROLITIC CLEANING:**  
Pyrolytic cleaning at 500°C destroys all the dirt deposits inside the oven. The Eco pyrolytic cleaning function can be selected when the oven has a lighter build up of dirt. This function has a maximum duration of 1.5 hours.

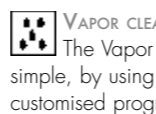
 **VAPOR CLEAN**  
The Vapor Clean function makes cleaning simple, by using steam generated using a customised programme.

SYMBOLS

 This symbol indicates that during pyrolytic cleaning the outer door glass will become no hotter than 55°C.





**FAST FREEZE**  
This option is particularly useful when you want to freeze a large quantity of fresh food.

 Closed door grilling and cooking keeps cooking smells inside the oven and out of the kitchen, ensures a safe cooking environment and reduces energy consumption.



**FROST FREE**  
This system prevents ice forming on the sides of the appliance. Frost free products do not require defrosting.

 Oven with 60 litre maxi cavity has 18% more usable space than previous models.

 Oven with 68 litre maxi plus capacity has up to 35% more usable space than previous models.



The Energy Savings Trust only recommends products with the best energy efficiency ratings within the category.

Quality, Environmental and Occupational Health & Safety Management Systems

All Smeg factories are ISO9001, ISO14001 and OHSAS 18001 certified, ensuring that the highest standards of quality are continually maintained whilst actively responding to all environmental issues relating to manufacture. The materials and components used to produce smeg products undergo strict quality control testing, and care is taken to source recyclable materials wherever possible. These management systems enable Smeg to provide complete assurance that all products meet superior standards whilst respecting the environment. The workforce is not forgotten – the occupational health and safety assessment scheme promotes a safe and healthy working environment, aids legislative compliance and helps improve overall performance.



UNI EN ISO 9001



UNI EN ISO 14001



OHSAS 18001

Whereas every effort has been made to ensure that the information contained in our literature is correct at time of going to print, this brochure should not be regarded as an infallible guide to current specification, nor does it constitute an offer for sale of any particular product.



**Smeg (UK) Limited**

3 Milton Park, Abingdon  
Oxon OX14 4RN  
[www.smeguk.com](http://www.smeguk.com)

**Information line**

Tel. 0844 5579907 Fax. 0844 5579337

**Trade enquiries**

Tel. 0844 5570070 Fax. 0844 5574355

**Service & Spare Parts**

Tel. 0844 5579907 Fax. 0844 5579336