



Smeg philosophy

Distinctive domestic appliances developed in collaboration with leading architects of the world. Products that express "Made in Italy" style by perfectly combining design, performance, and attention to detail. Smeg. Technology with style.

OVERVIEW	2
OPERA COOKERS	8
SYMPHONY COOKERS	14
CONCERT COOKERS	18
ACCESSORIES	26
CHARTS AND FUNCTIONS	28



Smeg was established in 1948 as an enamelling plant, working with metals; the acronym of Smeg (Smalterie Metallurgiche Emiliane Guastalla) serves as a memory of the initial activity carried out by the Company.

SMEG COOKERS,
CHOOSING QUALITY



Smeg cookers are design icons, combining style and remarkable performance in every way.

AN AMPLE RANGE

A passion for cooking deserves an outstanding cooker, with a harmonious blend of practicality and style. Inspired by the cookers used by the world's great chefs, Smeg offers genuine design icons where style and elegance go hand in hand with extreme versatility.

Available in a number of different dimensions from 60cm wide to 150cm, Smeg cookers are guaranteed to satisfy every space requirement.

The range includes cookers with diverse capacities, from the smallest 27 litre capacity to an ample 109 litres. Choose from single, double (horizontal or vertical) and triple ovens, with a gas, ceramic or induction hob-top. Available in three diverse designs – Opera, Symphony or Concert – and in a number of different finishes, all with their own style-coordinated hood and splashback, they present a complete item of furniture with which you can personalise your environment.

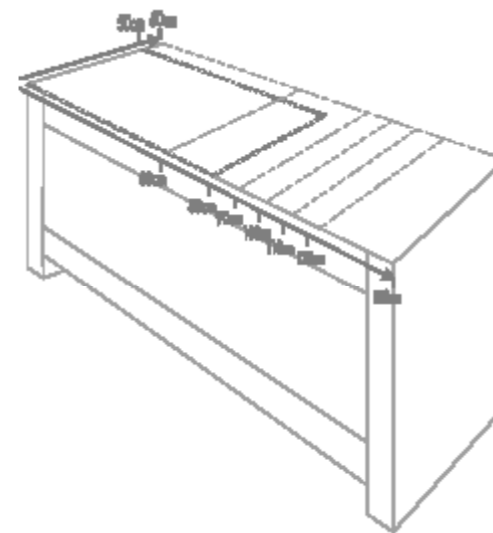

DOUBLE OVEN

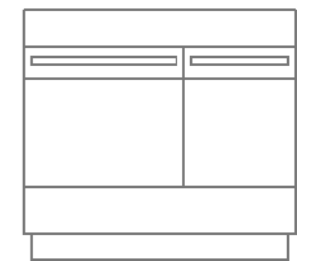

SIDE BY SIDE OVENS

Smeg cookers can be elegantly slotted in between other fitted kitchen furniture for a distinctive choice that is totally safe, thanks to the excellent insulation and outer cooling system that prevents the sides of Smeg cookers from over-heating.

Colours

Smeg appliances are constantly in line with the latest design trends. All features are designed to combine ease of use with innovation and research. These cookers are appealing, practical yet distinctive and styled to enhance the appearance of modern kitchens. Various colour options allow you to select a cooker that will coordinate perfectly with your kitchen. Smeg cookers are available in gloss black, st/steel or gloss cream finish.



ST/STEEL



GLOSS BLACK



GLOSS CREAM

Low energy consumption



Almost all the ovens in Smeg cookers are **A energy rated**, designed to perform at maximum efficiency while reducing energy consumption to the minimum.

The maxi plus 68 litre oven is capacious enough to be deemed a large rather than a medium oven, yet can save up to 20% of the energy used when compared with other large ovens.

GAS HOB TOPS

Spacious and practical, Smeg hob tops offer **multiple burner solutions** and can also be adapted for LPG.

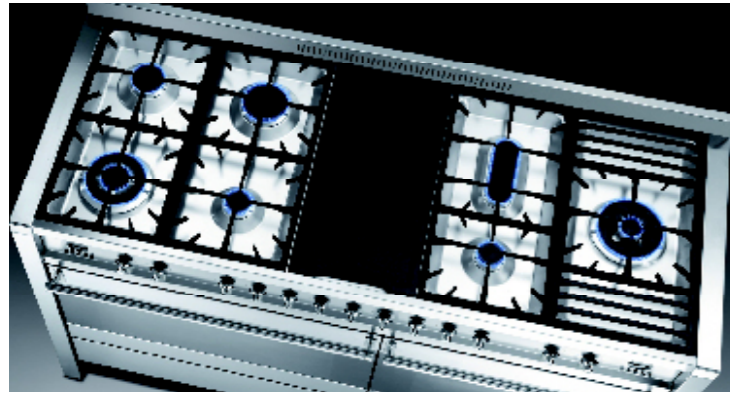

Gas hob tops each include at least one ultra rapid burner, an auxiliary burner and a mix of rapid and semi rapid burners. Ultra Rapid burners provide 3 solutions in 1, consisting of a double crown created by pairing a rapid burner with an auxiliary which function separately or together providing up to 4.5kW of power. Some models include an **elliptical burner** designed to cook fish, and many also feature a special **Teflon-coated cast iron griddle** - a genuine indoor barbecue! Just a little water under the plate stops food residues sticking to the st/steel underneath. All gas hobs have **safety valves**, and feature flat heavy duty cast iron pan stands.

Cooking accessories

A range of accessories helps make your Smeg cooker even more flexible.



A special **wok support** is ideal for lovers of oriental cuisine as it supports a wok perfectly.



The teppanyaki grill plate offers a different cooking style option, using a hot plate to grill food and seal in the flavours.

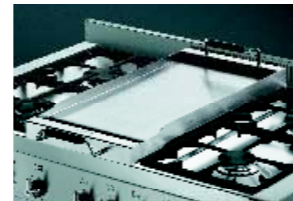

Contains spillages

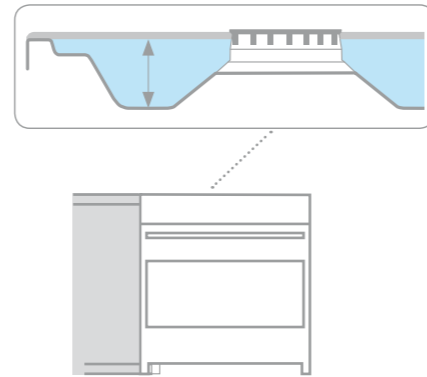

In contrast to many traditional cookers, all Smeg hob tops have an **anti-overflow feature**, with the 90 cm models capable of holding 4.5 litres. This special feature avoids spills of liquid thus protecting the kitchen furniture on either side.

FOCUS ON OVENS

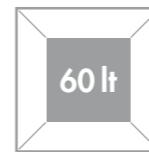
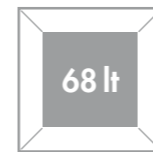

The 60cm ovens have become either maxi plus 68 litres net (79 litres gross) or maxi 60 litres net (68 litres gross) and these offer considerable extra space in the oven and all feature a special base designed to take a pizza stone.

Extra Space

Many cookers now have MAXI cavities providing greater usable space inside the oven. Features such as 5 cooking positions (for 68 litres cavities), telescopic shelves (for some models) and better side lighting (68 litre models have 2 halogen lamps) are included.



Safe Cook



Closed door grilling and cooking is an important feature in Smeg ovens, keeping cooking smells inside the oven and out of the kitchen, ensuring a safe cooking environment and **reducing energy consumption**. This is made possible as Smeg incorporate its excellent air cooling system in all cookers. Many models include a switch which automatically turns off the power when the door is open, maintaining minimum energy consumption.

Air cooling system

The fresh forced air recirculation system means that the door and its components inside the oven remain cool, ensuring greater safety and a longer life for your appliance. The cooling system remains in operation even when cooking is finished, continuing to function with the oven switched off, so as to dissipate the heat that has accumulated inside.

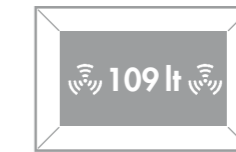

Also of note are the single oven 80cm and 90cm cookers with **extra wide** ovens, in particular the double fan 90cm oven, with an extremely generous capacity of 109 litres net (126 litres gross). These models are ideal for large families or batch baking.

CLEANING MADE SIMPLE

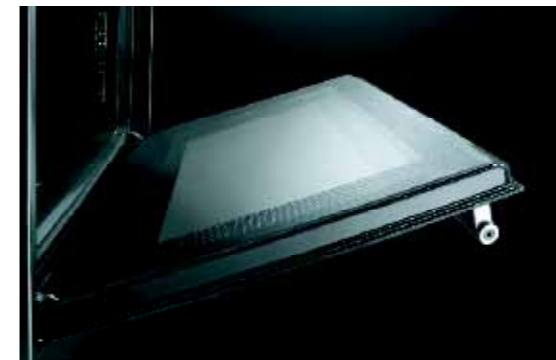

Many models feature the **all glass inner door**, with a completely flat surface to facilitate cleaning, and newly updated models include two **removable inner door glasses**, which are easily detached for cleaning. A number of cookers have **removable roof liners**, which simply slide out for cleaning, and can even be put in the dishwasher.

P Ovens with **pyrolytic cleaning** are becoming ever more popular, as consumers realise that they have free time to spend more usefully while the oven cleans itself automatically. A Smeg cooker with a single pyrolytic oven and a gas hob only requires a **standard 13 amp plug**, since it uses no more than 3 kW to complete the pyrolytic cleaning process.



Many models with the maxi cavity ovens which do not feature pyrolytic cleaning offer the Vapor Clean programme instead, which uses steam to loosen the deposits on the oven interior and at the end of the programme the cavity can be simply wiped clean.

ELECTRIC HOB TOPS



Ceramic hob

Cookers with ceramic hobs can be found in the Symphony and Concert ranges in both 60 and 90cm widths. The varied heating zones range from a single 145mm diameter to a dual oval zone of between 190mm and 290mm, suitable for a fish kettle or large oval pan. The ceramic hobs have automatic safety cut-outs and individual residual heat indicators for all the cooking zones.



Induction hob

Induction hobs can be found within the Opera and Symphony ranges, and they have been teamed up with ovens with pyrolytic cleaning to make an outstanding combination. Ferrous based pans must be used for induction cooking, which means the surface of the hob is not heated, instead it only picks up residual heat from the pan base making cleaning so much easier and enables the hob top to remain **hygienically clean**. The **quick reaction** of the cooking zones and the increased safety of the cooking system make induction hobs a superb choice for professional cooking with **energy consumption reduced** to a minimum.

CUSTOM FIT

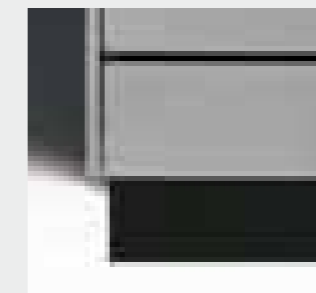

Most Symphony and Concert cookers have been re-designed at the base to give custom options on the style and height. Each cooker is supplied with a set of 4 stainless steel adjustable feet and black metal plinth sections. The feet can be used alone, allowing the overall cooker height to vary between 880mm and 915mm, or if the standard 900mm height is required and the style of a sleek black plinth preferred, then the optional plinth sections can be fitted.

COOKERS WITH REAL AESTHETIC APPEAL

Opera Cookers, style leaders

Clever combinations of features, technology and style have produced the **truly versatile** series of Smeg Opera Cookers. The serious cook can select a beautiful design object to enhance the kitchen, which can reflect the skill of its owner by providing excellent culinary results from its **wealth of functions and features**.



The **stylish analogue clock** with electronic programming, as well as adding an exclusive touch of class, offers a convenient cooking solution, allowing you to program the start and stop of cooking times.

Cast iron pan stands for a stylish finish guarantee maximum safety with more stability so that pans can be easily moved from burner to burner. Opera Cookers can be co-ordinated with a matching splashback and hood to complete the elegant look.

Apart from the 90cm models with a single extra large 70 litre capacity oven, all Opera range cookers have two ovens. Main ovens are multifunction, with capacities between 60 and 70 litres, all featuring a **comprehensive choice of oven functions**. All auxiliary ovens feature grills and conventional cooking, while some models also offer a rotisserie and can be fitted with a plate rack as an accessory. Furthermore a spacious drawer under all ovens provides a convenient solution to tidy away kitchen utensils.

Concert Cookers, distinctive design

This comprehensive collection of cookers combines **clean design lines** with high quality components and the result is a selection of appliances which are practical, **easy to use** and which produce excellent results for today's cook.



The Concert collection has a distinctive design with a softly rounded top, flat cast iron pan stands or ceramic hob, in a variety of widths and depths. Classic controls and solid stylish doors with characteristic Classic handles complete the design, which co-ordinates well with other Smeg appliances.



Symphony cookers, the perfect kitchen partner

The aesthetic style of the Symphony range conveys the look and feel of a **specialist kitchen** in a domestic environment. By using Classic elements in its design, this range is **extremely versatile** and able to co-ordinate with a wide range of Smeg products.



The Symphony collection includes versions in 60cm and 90cm widths with gas, ceramic and induction hobs, in addition to the original 110cm 4 cavity range cooker. The 90cm and 60cm models in the Symphony range feature ovens with pyrolytic cleaning wherever possible offering added convenience to the consumer.



The Symphony range is characterised by a contemporary and **distinctive square design** and introduced the first four cavity Smeg cooker before adding other size options in the series. Featuring distinctive **ergonomic control knobs** and stainless steel handles, this range is a clear extension of the Classic family. The cookers offer the ability to achieve excellent culinary results using an extensive **array of functions** and features that allow for simultaneous cooking of a diverse range of foods at varying temperatures.

COORDINATED COOK ZONE WITH NEW GLASS SPLASHBACKS & UPSTANDS



The Smeg range now includes a number of eye-catching glass splashbacks and upstands. Eye catching, hygienic, and easy to fit, they are available in 8 stunning colours and finishes chosen specifically to complement the Smeg product range and create a completely personalised cook zone with striking aesthetic impact.

They are also an extremely cost effective alternative to tiles and result in a smooth and seamless finish. For more information please see page 27 or visit www.smeguk.com.

A5-8

150CM "OPERA" DUAL CAVITY COOKER WITH GAS HOB & ELECTRIC GRIDDLE, ST/STEEL
ENERGY RATING AA



MAIN OVEN:
9 functions



Oven capacity: gross - 90 litres, net - 70 litres
Analogue LED electronic clock/programmer
Air cooling system
Closed door grilling
Triple glazed removable door
Rotisserie
Stay clean liners

AUXILIARY OVEN:
8 functions



Oven capacity: Gross 68 litres, net 60 litres
Analogue LED electronic clock/programmer
Triple glazed removable door
Air cooling system
Closed door grilling
Special pizza cooking function
Stay clean liners

Pull out full width storage drawer

HOB:

7 Burners + Griddle
Rear left: 1.80kW
Front left: Ultra Rapid 4.2kW
Rear left centre: Rapid 3.0kW
Front left centre: 1.00kW
Electric griddle: 1.60kW with Teflon coated plate
Rear right centre: Fishburner 1.90kW
Front right centre: 1.00kW
Right centre: Ultra Rapid dual flame 3-way burner 4.5kW (3.5+1.0kW)



Heavy duty cast iron pan stands
Chrome wok support
Automatic electronic ignition
Safety valves
LPG adaptable

Power supply required: dedicated cooker circuit fused at 40/45 amp

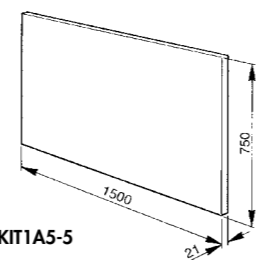
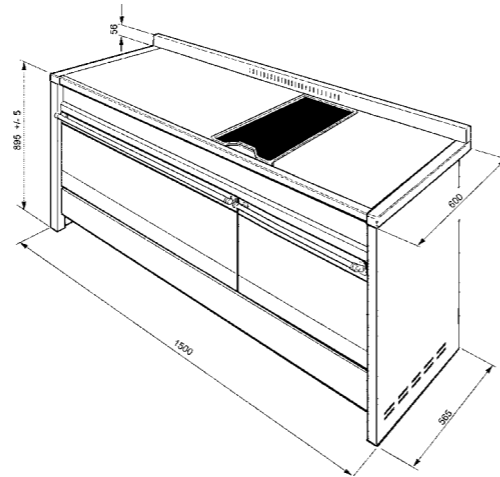

KIT1A5-5

A4BL-8

120CM "OPERA" DUAL CAVITY COOKER WITH GAS HOB & ELECTRIC GRIDDLE, GLOSS BLACK
ENERGY RATING AA



MAIN OVEN:
9 functions



Oven capacity: gross 68 litres, net 60 litres
Analogue LED electronic clock/programmer
Air cooling system
Closed door grilling
Triple glazed removable door
Rotisserie
Stay clean liners

AUXILIARY OVEN:
6 functions



Oven capacity: Gross 61 litres, net 54 litres
Minute minder
Air cooling system
Closed door grilling
Triple glazed removable door
Special pizza cooking function
Stay clean liners

Pull out full width storage drawer

HOB:

6 Burners + Griddle
Rear left: 1.80kW
Front left: Ultra Rapid 4.2kW
Rear centre: Rapid 3.0kW
Front centre: 1.0 kW
Electric griddle: 1.60kW with Teflon coated plate
Rear right: Fishburner 1.90kW
Front right: 1.0 kW



Heavy duty cast iron pan stands
Chrome wok support
Automatic electronic ignition
Safety valves
Adaptable for LPG

Power supply required: dedicated cooker circuit fused at 30 amp or a 32 amp circuit breaker

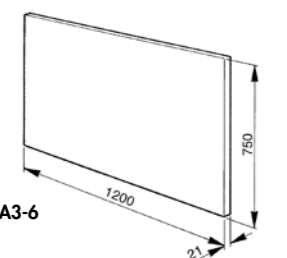
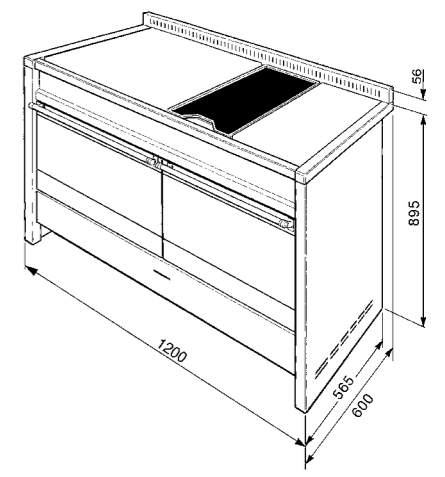

KIT1A3-6



A4-8
St/steel

For additional information see pages 28-32

A3-7

120CM "OPERA" DUAL CAVITY COOKER WITH GAS HOB & ELECTRIC GRIDDLE, ST/STEEL
ENERGY RATING AA



MAIN OVEN:
9 functions



- Oven capacity: gross - 90 litres, net - 70 litres
- Analogue LED electronic clock/programmer
- Air cooling system
- Closed door grilling
- Triple glazed removable door
- Rotisserie
- Stay clean liners

AUXILIARY OVEN (STATIC OVEN):
4 functions

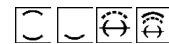

- Oven capacity: gross - 42 litres, net - 35 litres
- Air cooling system
- Closed door grilling
- Triple glazed removable door
- Rotisserie
- Variable grill

Pull out full width storage drawer beneath the ovens

- HOB:
- 6 Burners + Griddle
 - Rear left: 1.80kW
 - Front left: Ultra Rapid 4.2kW
 - Rear centre: Rapid 3.0kW
 - Front centre: 1.05kW
 - Electric griddle 1.60kW with Teflon coated plate
 - Rear right: Fishburner 1.90kW
 - Front right: 1.05kW
 - Heavy duty cast iron pan stands
 - Chrome wok support
 - Automatic electronic ignition
 - Safety valves
 - Adaptable for LPG

Power supply required: dedicated cooker circuit fused at 30 amp or a 32 amp circuit breaker

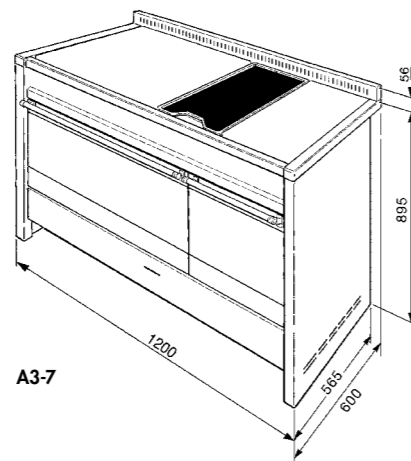

A3-7

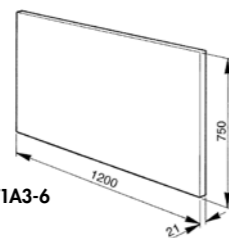

KITIA3-6

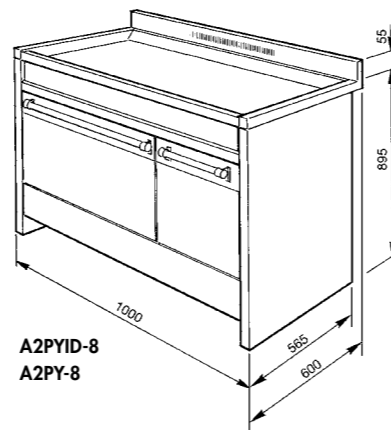

A2PYID-8
A2PY-8

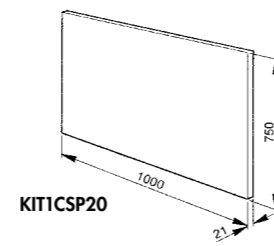

KITCSP20

For additional information see pages 28-32

A2PYID-8 PYROLITIC AND INDUCTION

100CM "OPERA" DUAL CAVITY COOKER WITH MULTIFUNCTION PYROLITIC OVEN & INDUCTION HOB, ST/STEEL
ENERGY RATING AA



MAIN OVEN:
10 functions



- Oven capacity: gross - 68 litres, net - 60 litres
- Analogue LED electronic clock/programmer
- Air cooling system
- Closed door grilling
- Quadruple glazed removable door
- Rotisserie
- Pyrolytic cleaning

AUXILIARY OVEN:
6 Functions

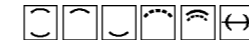

- Oven capacity: gross - 35 litres, net - 27 litres
- Air cooling system
- Closed door grilling
- Quadruple glazed removable door
- Rotisserie

Pull out full width storage drawer beneath the ovens

- HOB:
- 5 'full power' induction zones including
 - Right front: Ø 210 - 2.3 kW (booster 3.2 kW)
 - Right rear: Ø 145 - 1.4 kW (booster 1.8 kW)
 - Centre front: Ø 180 - 1.85 kW (booster 2.5 kW)
 - Left rear: Ø 145 - 1.4 kW (booster 1.8 kW)
 - Left front: Ø 210 - 2.3 kW (booster 3.2 kW)
 - Electronic pan detector for each zone
 - Low heat position on each zone to keep food warm
 - Residual induction heat indicators
 - Automatic safety cut-out

Power supply required: dedicated cooker circuit - consult a qualified electrician



A2PY-8 PYROLITIC

100CM "OPERA" DUAL CAVITY COOKER WITH MULTIFUNCTION PYROLITIC OVEN & GAS HOB, ST/STEEL
ENERGY RATING AA



MAIN OVEN:
10 functions



- Oven capacity: gross - 68 litres, net - 60 litres
- Analogue LED electronic clock/programmer
- Air cooling system
- Closed door grilling
- Quadruple glazed removable door
- Rotisserie
- Pyrolytic cleaning

AUXILIARY OVEN (STATIC OVEN):
6 functions



- Oven capacity: gross - 35 litres, net - 27 litres
- Air cooling system
- Closed door grilling
- Triple glazed removable door
- Rotisserie

Pull out full width storage drawer beneath the ovens

- HOB:
- 6 burners
 - Rear left: Ultra Rapid 4.2kW
 - Front left: 1.8kW
 - Rear centre: 1.8kW
 - Front centre: 1.0kW
 - Rear right: Rapid 3.0kW
 - Front right: Ultra Rapid 4.2kW
 - Heavy duty cast iron pan stands
 - Chrome wok support
 - Automatic electronic ignition
 - Safety valves
 - Adaptable for LPG

Power supply required: dedicated cooker circuit fused at 30 amp or a 32 amp circuit breaker



A2BL-8

100CM "OPERA" DUAL CAVITY COOKER WITH MULTIFUNCTION OVEN & GAS HOB, GLOSS BLACK
ENERGY RATING AA



MAIN OVEN:
8 functions



Oven capacity: Gross 68 litres, net 60 litres
Analogue LED electronic clock/programmer
Air cooling system
Closed door grilling
Triple glazed removable door
Stay clean liners

AUXILIARY OVEN (STATIC OVEN):
6 functions

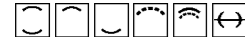

Oven capacity: gross - 35 litres, net - 27 litres
Air cooling system
Closed door grilling
Triple glazed removable door
Rotisserie

Pull out full width storage drawer beneath the ovens

HOB:

6 burners
Rear left: Ultra Rapid 4.2kW
Front left: 1.8kW
Rear centre: 1.8kW
Front centre: 1.00kW
Rear right: Rapid 3.0kW
Front right: Ultra Rapid 4.2kW
Heavy duty cast iron pan stands
Chrome wok support
Automatic electronic ignition
Safety valves
Adaptable for LPG

Power supply required: dedicated cooker circuit fused at 30 amp or a 32 amp circuit breaker



A2-8
St/steel



For additional information see pages 28-32

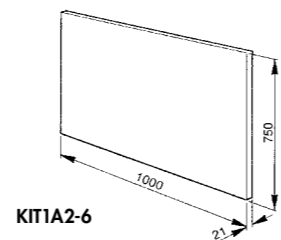
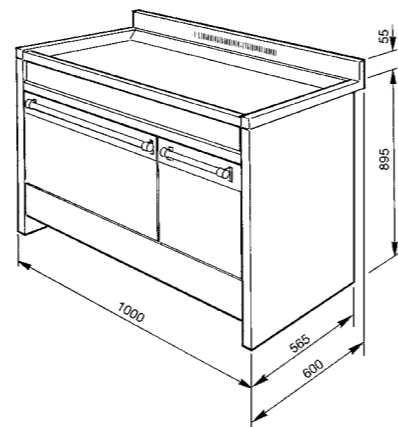

KITIA2-6

A1P-9

90CM "OPERA" COOKER WITH MULTIFUNCTION OVEN & GAS HOB, GLOSS CREAM
ENERGY RATING A



OVEN:
9 functions



Oven capacity: gross - 90 litres, net - 70 litres
Analogue LED electronic clock/ programmer
Air cooling system
Closed door grilling
Triple glazed removable door
Rotisserie
Stay clean liners
Storage drawer beneath the oven

HOB:

6 burners
Rear left: Rapid 3.0kW
Front left: Ultra Rapid 4.2kW
Rear centre: Fishburner 1.9kW
Front centre: 1.05kW
Rear right: Rapid 3.0kW
Front right: 1.8kW
Heavy duty cast iron pan stands
Chrome wok support
Automatic electronic ignition
Safety valves
Adaptable for LPG

Power supply required: 13 Amp fused plug



A1-7
St/steel



A1BL-7
Gloss black

A1PYID-7 PYROLITIC AND INDUCTION

90CM "OPERA" COOKER WITH MULTIFUNCTION PYROLITIC OVEN & INDUCTION HOB, ST/STEEL
ENERGY RATING A



OVEN:
10 functions



Oven capacity: gross - 90 litres, net - 70 litres
Analogue LED electronic clock/ programmer
Air cooling system
Closed door grilling
Quadruple glazed removable door
Pyrolytic cleaning
Rotisserie
Storage drawer beneath the oven

HOB:

5 "full power" induction zones, including
Right front: Ø 145 - 1.1 kW (booster 2.2 kW)
Right rear: Ø 210 - 2.3 kW (booster 3.7 kW)
Centre front: Ø 260 - 2.4 kW (booster 3.7 kW)
Left rear: Ø 180 - 1.85 kW (booster 3.0 kW)
Left front: Ø 145 - 1.1 kW (booster 2.2 kW)
Automatic safety cut-out
Residual heat indicators
Low heat position on each zone for keeping food warm

Power supply required: dedicated cooker circuit - consult a qualified electrician

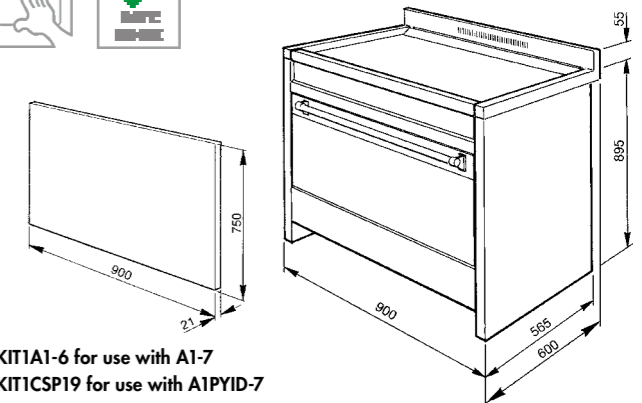

KITIA1-6 for use with A1-7
KITICSP19 for use with A1PYID-7

SY4110-8

110cm "SYMPHONY" DUAL FUEL FOUR CAVITY RANGE COOKER,
STAINLESS STEEL
ENERGY RATING AA



MAIN OVEN - TOP RIGHT:
7 functions



Oven capacity: gross 68 litres, net 60 litres
Digital electronic clock/programmer
Air cooling system
Closed door grilling
Double glazed removable door
Vapor Clean

AUXILIARY OVEN (STATIC OVEN) - LOWER LEFT:
6 functions



Oven capacity: gross 68 litres, net 60 litres
Air cooling system
Closed door grilling
Double glazed removable door

GRILL COMPARTMENT - TOP LEFT:



Oven capacity: gross - 35 litres, net 27 litres
Air cooling system
Closed door grilling
Full variable grill
Double glazed removable door
Max grill power: 2.7kW

Storage drawer - lower right:

Internal dimensions:
H160 x W375 x D390mm

HOB:

6 burners
Rear left: 1.00kW
Front left: Ultra Rapid burner 4.0kW
Rear Centre: 1.75kW
Front Centre: 1.00kW
Rear right: Rapid burner 3.00kW
Front right: 1.75kW
Warming zone 130°C

Heavy duty cast iron pan stands
Automatic electronic ignition
Safety valves
Adaptable for LPG

Power supply required: dedicated cooker circuit fused at 40/45 amp

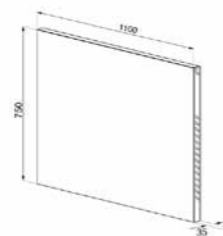
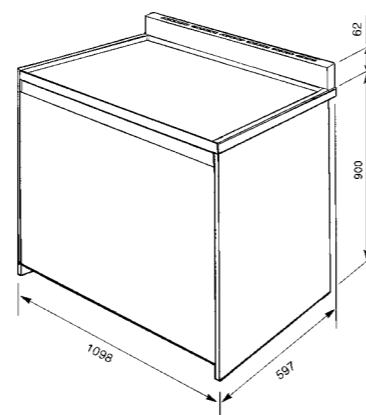

KITS110X8

For additional information see pages 28-32



SY4110BL8
KITS110X8
KSE110BL

SY92IPX8 PYROLITIC AND INDUCTION

90CM 'SYMPHONY' DUAL CAVITY COOKER WITH MULTIFUNCTION **PYROLITIC** OVEN AND INDUCTION HOB, ST/STEEL
ENERGY RATING AA



Photo shows legs & plinth fitted

SY92PX8 PYROLITIC

90CM 'SYMPHONY' DUAL CAVITY COOKER WITH MULTIFUNCTION **PYROLITIC** OVEN AND GAS HOB, ST/STEEL
ENERGY RATING AA



Photo shows legs only fitted

BOTH MODELS THIS PAGE:

MAIN OVEN:
10 functions



SY92IPX8 oven capacity: gross 79 litres, net 68 litres

SY92PX8 oven capacity: gross 79 litres, net 68 litres

Digital electronic clock/programmer

Air cooling system

Closed door grilling

Removable roof liner

Removable inner door glasses

Quadruple glazed removable door

Rotisserie

Pyrolytic cleaning



AUXILIARY OVEN (STATIC OVEN):
4 functions

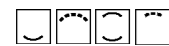

Oven capacity: gross - 35 litres, net - 27 litres

Air cooling system

Closed door grilling

Storage compartment beneath the ovens

St/steel feet and black plinth provided

SY92IPX8 HOB:

5 full power **induction** zones

Rear left: Ø 180mm, 1.85 kW (booster 3.0kW)

Front left: Ø 145mm, 1.1 kW (booster 2.2 kW)

Centre: Ø 260mm, 2.4 kW (booster 3.7 kW)

Rear right: Ø 210mm, 2.3 kW (booster 3.7 kW)

Front right: Ø 145mm, 1.1 kW (booster 2.2 kW)

Power supplies required:

SY92IPX8: dedicated cooker circuit - consult a qualified electrician

SY92PX8: dedicated cooker circuit fused at 30 Amp, or a 32 Amp circuit breaker

SY92PX8 HOB

6 burners

Rear left: 1.0kW

Front left: Ultra Rapid 4.0kW

Rear Centre: 1.75kW

Front Centre: 1.0kW

Rear right: Rapid 3.0kW

Front right: 1.75kW

Heavy duty cast iron pan stands

Safety valves

Automatic ignition

Adaptable for LPG

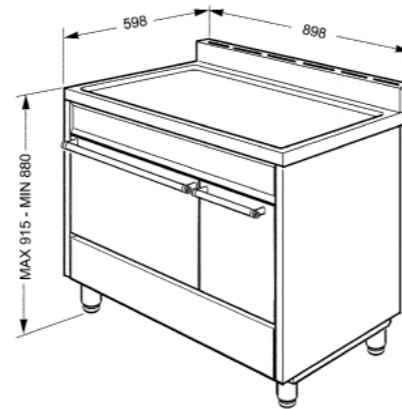

NB: Height with plinth installed is fixed at 900mm

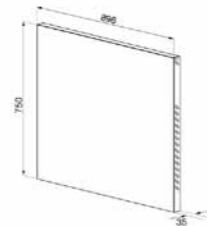

SY92IPX8 - Splashback KITC9X
SY92PX8 - Splashback KITC9X



SY62MX8 - Splashback KITC6X
SY6CPX8 - Splashback KITC6X

For additional information see pages 28-32

SY62MX8

60CM 'SYMPHONY' COOKER WITH DOUBLE OVEN AND GAS HOB, ST/STEEL
ENERGY RATING AA



MAIN OVEN:
7 functions



Oven capacity: gross - 68 litres, net - 60 litres

Digital electronic clock/programmer

Air cooling system

Closed door grilling

Removable roof liner

Removable inner door glasses

Double glazed removable door

Vapor clean

AUXILIARY OVEN (STATIC OVEN):
4 functions

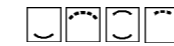

Oven capacity: Gross 41 litres, net 27 litres

Air cooling system

Closed door grilling

Removable roof liner

Double glazed removable door

HOB:

4 burners

Rear left: 1.8kW

Front left: Ultra Rapid 4.0kW

Rear right: 1.8kW

Front right: 1.0kW

Heavy duty cast iron pan stands

Safety valves

Automatic ignition

Adaptable for LPG

Power supply required:

dedicated cooker circuit fused at 30 Amp, or a 32 Amp circuit breaker

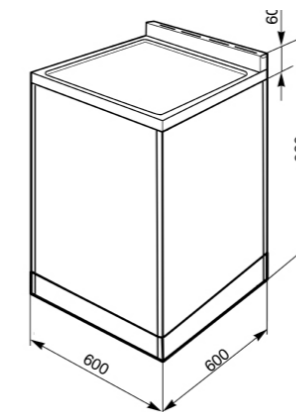

SY6CPX8 PYROLITIC

60CM 'SYMPHONY' COOKER WITH **PYROLITIC** OVEN AND CERAMIC HOB, ST/STEEL
ENERGY RATING A



Photo shows legs only fitted

OVEN:
10 functions



Oven capacity: gross - 79 litres, net - 68 litres

Digital electronic clock/programmer

Air cooling system

Removable roof liner

Closed door grilling

Removable inner door glasses

Quadruple glazed removable door

Pyrolytic cleaning

Storage compartment beneath the oven

St/steel feet and black plinth provided

HOB:

4 Highlight radiant zones, including 2 dual zones

Rear left: Ø 145mm, 1.2 kW

Front left dual zone: Ø 120/210mm, 0.75/2.2 kW

Rear right dual zone: Ø 170/265mm, 1.4/2.2 kW

Front right: Ø 180mm, 1.8 kW

Residual heat indicators

Automatic safety cut-out

Power supply required:

dedicated cooker circuit

- consult a qualified electrician

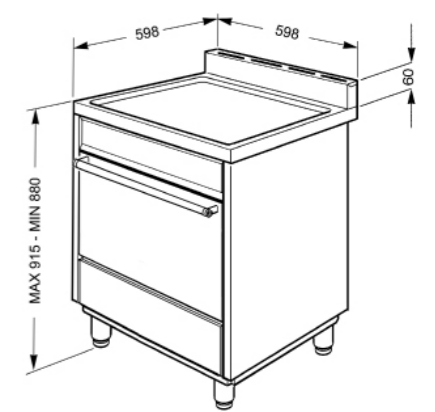
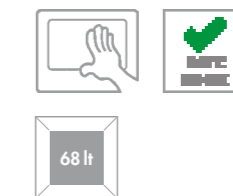

NB: Height with plinth installed is fixed at 900mm

SUK92MP9

90CM "CONCERT" COOKER WITH DOUBLE OVEN & GAS HOB, GLOSS CREAM ENERGY RATING AA



Photo shows legs & plinth fitted

MAIN OVEN:
7 functions



Oven capacity: gross - 70 litres, net - 60 litres
Digital electronic clock/programmer
Air cooling system
Closed door grilling
Removable inner door glasses
Vapor clean

AUXILIARY OVEN (STATIC OVEN):
4 functions

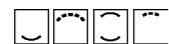

Oven capacity: gross - 35 litres, net - 27 litres
Air cooling system
Closed door grilling

Storage compartment beneath the ovens
St/steel feet and black plinth provided

HOB:

5 burners
Rear left: 1.8kW
Front left: Rapid 3.0kW
Centre: Ultra Rapid 3.5kW
Rear right: 1.8kW
Front right: 1.0kW
Heavy duty cast iron pan stands
Automatic electronic ignition
Safety valves
Adaptable for LPG

Power supply required: dedicated cooker circuit fused at 30 Amp, or a 32 Amp circuit breaker

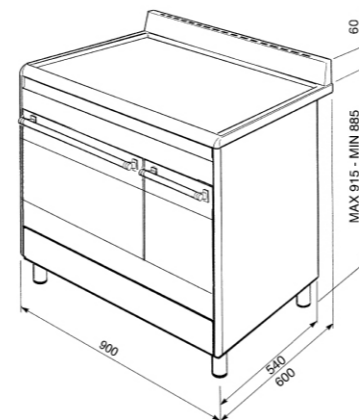

NB: Height with plinth installed is fixed at 900mm

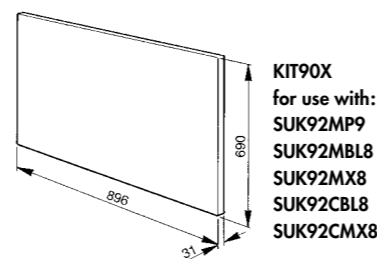

SUK92MBL8
Gloss black

SUK92MX8
St/steel

SUK92CBL8

90CM "CONCERT" COOKER WITH DOUBLE OVEN & CERAMIC HOB, GLOSS BLACK ENERGY RATING AA



Photo shows legs only fitted

MAIN OVEN:
7 functions



Oven capacity: gross - 70 litres, net - 60 litres
Digital electronic clock/programmer
Air cooling system
Closed door grilling
Removable inner door glasses
Vapor Clean

AUXILIARY OVEN (STATIC OVEN):
4 functions



Oven capacity: gross - 35 litres, net - 27 litres
Air cooling system
Closed door grilling

Double storage compartment beneath the ovens
St/steel feet and black plinth provided

HOB:

5 radiant 'High-Light' zones, including 2 dual
Rear left: Ø 195mm, 2.0kW
Front left: Ø 140mm, 1.2kW
Central dual zone: Ø 170/265mm, 1.4/2.2kW
Rear right dual zone: Ø 140/210mm, 0.75/2.2kW
Front right: Ø 140mm, 1.2kW
Residual heat indicators
Automatic safety cut-out

Power supply required: dedicated cooker circuit - consult a qualified electrician



SUK92CMX8
St/steel

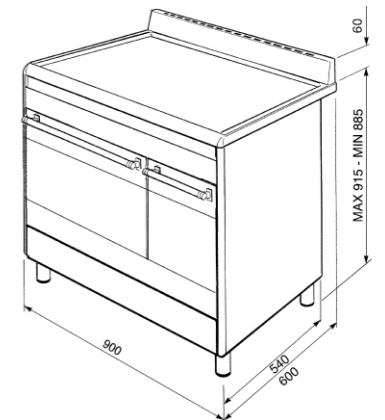

NB: Height with plinth installed is fixed at 900mm

For additional information see pages 28-32

SUK91MFX7

90CM "CONCERT" COOKER WITH MULTIFUNCTION OVEN & GAS HOB, ST/STEEL
ENERGY RATING B



OVEN:
6 functions

-
- Oven capacity: gross - 126 litres, net - 109 litres
- Digital electronic clock/programmer
- Extra wide oven
- Double fan cooking
- Air cooling system
- Closed door grilling
- Variable grill
- Rotisserie
- Storage compartment beneath the oven

HOB:
5 burners
Rear left: 1.75kW
Front left: Rapid 3.0kW
Centre: Ultra Rapid 3.5kW
Rear right: 1.75kW
Front right: 1.0kW
Heavy duty cast iron pan stands
Safety valves
Automatic electronic ignition
Adaptable for LPG

Power supply required: dedicated cooker circuit fused at 30 Amp or a 32 Amp circuit breaker

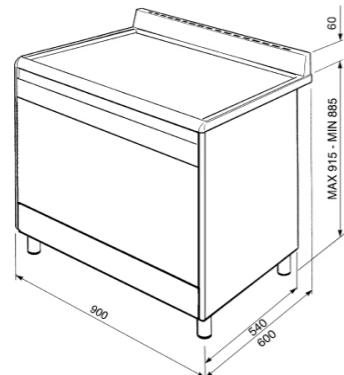

SUK91MBL7
Gloss black

SUK91CMX7

90CM "CONCERT" COOKER WITH MULTIFUNCTION OVEN & CERAMIC HOB, ST/STEEL
ENERGY RATING B



OVEN:
6 functions

-
- Oven capacity: gross - 126 litres, net - 109 litres
- Digital electronic clock/programmer
- Extra wide oven
- Double fan cooking
- Air cooling system
- Closed door grilling
- Variable grill
- Rotisserie
- Storage compartment beneath the oven

HOB:
5 radiant 'High-Light' zones, including 2 dual
Rear left: Ø 195mm, 2.0kW
Front left: Ø 140mm, 1.2kW
Central dual zone: Ø 170/265mm, 1.4/2.2kW
Rear right dual zone: Ø 140/210mm, 1.4/2.2kW
Front right: Ø 140mm, 1.2kW
Residual heat indicators
Automatic safety cut-out

Power supply required: Dedicated cooker circuit - consult a qualified electrician

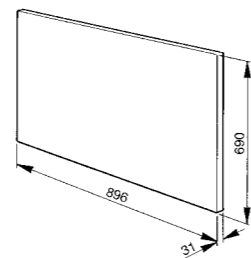

KIT90X
for use with:
SUK91MFX7
SUK91MBL7
SUK91CMX7

SUK81MBL5

80CM "CONCERT" COOKER WITH MULTIFUNCTION OVEN & GAS HOB, GLOSS BLACK
ENERGY RATING A



OVEN:
6 functions

-
- Oven capacity: gross - 109 litres, net - 78.5 litres
- Digital electronic clock/programmer
- Extra wide oven
- Cooling fan
- Variable grill
- Rotisserie
- Air cooling system
- Closed door grilling
- Storage compartment beneath the oven

HOB:
5 burners
Rear left: 1.75kW
Front left: Rapid 2.3kW
Centre: Ultra Rapid 3.5kW
Rear right: 1.75kW
Front right: 1.0kW
Heavy duty cast iron pan stands
Safety valves
Automatic electronic ignition
Adaptable for LPG

Power supply required: 13 Amp fused plug



SUK81MFX5
St/steel

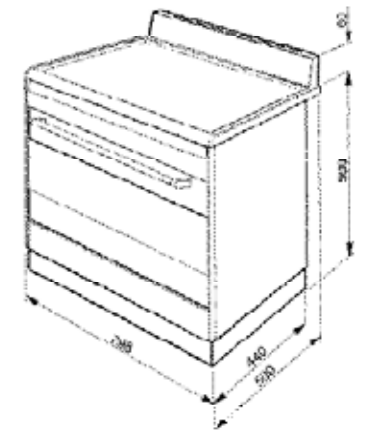

For additional information see pages 28-32

SUK62MX8

60CM "CONCERT" COOKER WITH DOUBLE OVEN & GAS HOB, ST/STEEL
ENERGY RATING AA



MAIN FAN OVEN:
 Circulaire

Oven capacity: gross - 70 litres, net - 60 litres
Digital electronic clock/programmer
Air cooling system
Removable inner door glass

AUXILIARY OVEN (STATIC OVEN):

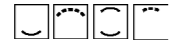

4 functions
Oven capacity: gross 41 litres, net 27 litres
Air cooling system
Closed door grilling

HOB:
4 burners
Rear left: 1.8kW
Front left: Ultra Rapid 4.0kW
Rear right: 1.8kW
Front right: 1.0kW
Heavy duty cast iron pan stands
Safety valves
Automatic electronic ignition
Adaptable for LPG

Power supply required: dedicated cooker circuit fused at 30 Amp, or a 32 Amp circuit breaker



SUK62MBL8
Gloss black

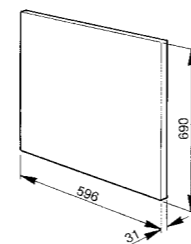

KIT60X
for use with:
SUK62MX8
SUK62MBL8
SUK62CBL8
SUK62CMX8

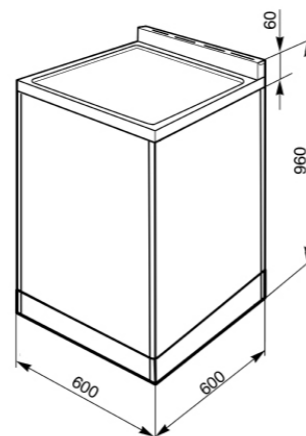

SUK62CBL8

60CM "CONCERT" COOKER WITH DOUBLE OVEN & CERAMIC HOB, GLOSS BLACK
ENERGY RATING AA



MAIN FAN OVEN:
 Circulaire

Oven capacity: gross - 70 litres, net - 60 litres
Digital electronic clock/programmer
Air cooling system
Removable inner door glass

AUXILIARY OVEN (STATIC OVEN):

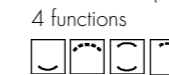

4 functions
Oven capacity: gross 41 litres, net 27 litres
Air cooling system
Closed door grilling

HOB:
4 "High-Light" cooking zones including one 2-way circular zone and one oval dual zone
Rear left: Ø 145mm, 1.2kW
Front left: Ø 120/210mm, 0.75/2.2kW
Rear right: Ø 170/265mm, 1.4/2.2kW
Front right: Ø 180mm, 1.8kW
Residual heat indicators

Power supply required: dedicated cooker circuit - consult a qualified electrician



SUK62CMX8
St/steel

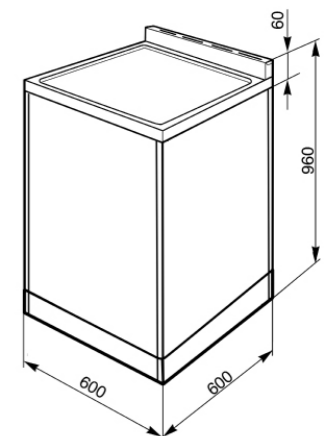

For additional information see pages 28-32

SUK61PX8

PYROLITIC

60CM "CONCERT" COOKER WITH MULTIFUNCTION
Pyrolitic OVEN & GAS HOB, ST/STEEL
 ENERGY RATING A



Photo shows legs & plinth fitted

OVEN:
 10 functions



- Oven capacity: gross - 79 litres, net - 68 litres
- Digital electronic clock/programmer
- Air cooling system
- Fully variable grill
- Closed door grilling
- Quadruple glazed removable cooler door
- Removable inner door glasses**
- Rotisserie
- Pyrolitic cleaning**

Storage compartment beneath the oven
 St/steel feet and black plinth provided

- HOB:
- 4 burners
 - Rear left: 1.75kW
 - Front left: Ultra Rapid 4.0kW
 - Rear right: 1.75kW
 - Front right: 1.0kW
 - Heavy duty cast iron pan stands
 - Safety valves
 - Automatic electronic ignition
 - Adaptable for LPG

Power supply required: 13 Amp fused plug

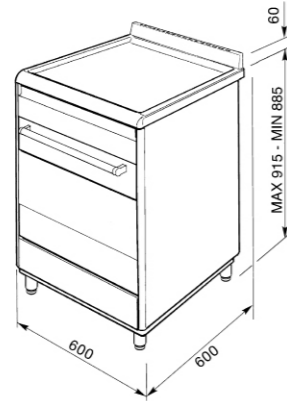

NB: Height with plinth installed is fixed at 900mm

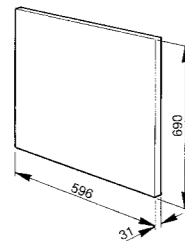

KIT60PX
 for use with:
SUK61PX8

SUK61MBL8

60CM "CONCERT" COOKER WITH MULTIFUNCTION OVEN &
 GAS HOB, GLOSS BLACK
 ENERGY RATING A



Photo shows legs only fitted

OVEN:
 7 functions



- Oven capacity: gross - 79 litres, net - 68 litres
- Digital electronic clock/programmer
- Air cooling system
- Fully variable grill
- Closed door grilling
- Removable inner door glass**
- Vapor clean**

Storage compartment beneath the oven
 St/steel feet and black plinth provided

- HOB:
- 4 burners
 - Rear left: 1.75kW
 - Front left: Ultra Rapid 4.0kW
 - Rear right: 1.75kW
 - Front right: 1.0kW
 - Heavy duty cast iron pan stands
 - Safety valves
 - Automatic electronic ignition
 - Adaptable for LPG

Power supply required: 13 Amp fused plug



NB: Height with plinth installed is fixed at 900mm



SUK61MX8
 St/steel

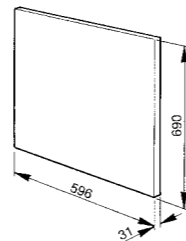

KIT60X
 for use with:
SUK61MBL8
SUK61MX8

For additional information see pages 28-32



SUK61PX8

COOKING ACCESSORIES

Smeg offers a variety of accessories for cookers, which enhance the appliances and provide added flexibility.

GTA-6

3 LEVEL TELESCOPIC SHELF SET

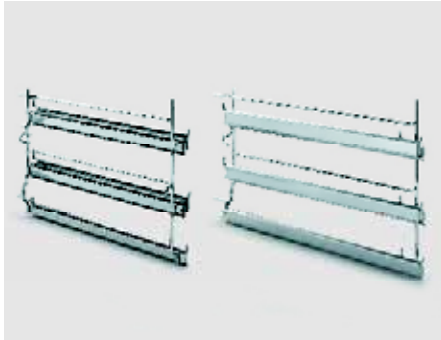

Telescopic shelf set with 3 levels suitable for use with A1-7 and A3-7

GT1T

1 LEVEL TELESCOPIC SHELF - TOTAL EXTRACTION

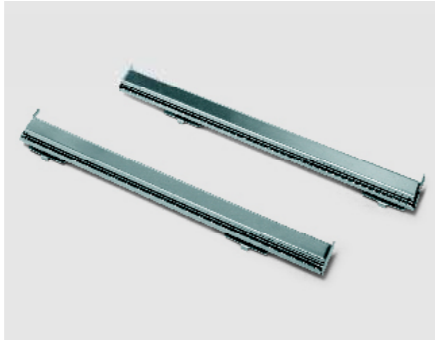

Pair of fully extractable telescopic guides suitable for use on some cookers with Maxi cavities.

Also Available: **GT1P** Telescopic shelf set with 1 partially extractable level

PRTX

PIZZA STONE WITH HANDLES



Refractory pizza stone with handle suitable for use with all Maxi ovens.

Also Available:
PALPZ Pizza shovel with fold away handle
PPR2 Universal pizza stone without handles

GO120

CAST IRON OPEN GRIDDLE FOR BARBECUE



The GO120 is intended to replace the Teflon plate on Opera range cookers with the electric griddle, to convert it to a barbecue.

GC120

CAST IRON RIBBED GRIDDLE



The GC120 can replace a pan stand on Opera 120cm & 150cm dual fuel range cookers to provide a griddle plate.

TPKX

TEPPANYAKI GRILL PLATE

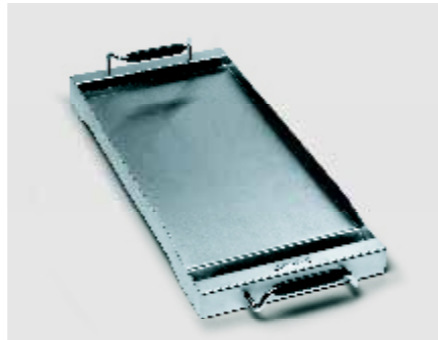

Stainless steel grill plate designed for cooking Teppanyaki dishes. Suitable for all Opera cookers with gas hobs.

TBX6090

TEPPANYAKI GRILL PLATE



The TBX6090 is a stainless steel grill plate, designed for cooking teppanyaki dishes. Suitable for Symphony and Concert cookers with cast iron pan stands.

PR7A2

PLATE WARMING RACK FOR 7 PLATES



The PR7A2 is a chrome 7-plate warming rack which fits the small oven in the A2 and SUK92 range cookers. A slightly larger 9-plate version, the PR9A3, fits the A3 Opera cooker.

WOKGHU

WOK SUPPORT



The WOKGHU offers additional stability when using a wok. Suitable for cookers with cast iron pan stands.

GLASS SPLASHBACKS & UPSTANDS



A number of eye-catching glass splashbacks have been introduced to the Smeg range, that are available in a wide choice of inspiring colours, finishes and sizes to enhance the diverse range of appliances.

The 8 colours available particularly complement the iconic Smeg 50's Retro appliances as well as Black, Cream and Stainless Steel products. There are also matching 140mm high upstands available which can be fitted on the wall behind the worktop. These can be cut to size by the installer to ensure a perfect fit.



Splashbacks are a practical addition to any kitchen as they are easy to clean, with no grout lines to collect dirt or grease. They are also a very cost effective alternative to tiles that are simple and easy to install and result in a smooth and seamless finish.

The table below shows the various colours and dimensions available.

DIMENSIONS	SPLASHBACKS				UPSTANDS
	60cm W x 75cm H	75cm W x 75cm H	75cm W x 32cm H	90cm W x 75cm H	2 x 100cm W x 14cm H
GLASS COLOUR	MODEL NOS	MODEL NOS	MODEL NOS	MODEL NOS	MODEL NOS
BLACK	SPG6075NE	SPG7575NE	SPG7532NE	SPG9075NE	UPGNE
CREAM	SPG6075P			SPG9075P	UPGP
RED	SPG6075R			SPG9075R	UPGR
PASTEL BLUE	SPG6075AZ			SPG9075AZ	UPGAZ
LIME	SPG6075VE			SPG9075VE	UPGVE
SILVER	SPG6075S	SPG7575S		SPG9075S	UPGS
MATT WHITE	SMG6075B	SMG7575B	SMG7532B	SMG9075B	UMGB
MATT BLACK	SMG6075NE	SMG7575NE	SMG7532NE	SMG9075NE	UMGNE

OPERA COOKERS

	A5	A4	A3	A2P	A2	A1	A1P
Colour Option (Gas Hob)							
Stainless Steel	A5-8	A4-8	A3-7		A2-8	A1-7	
Stainless Steel (pyrolytic cleaning)				A2PY-8			
Black		A4BL-8			A2BL-8	A1BL-7	
Cream						A1P-9	
Colour Option (Induction Hob)							
Stainless Steel (pyrolytic cleaning)				A2PYID-8			A1PYID-7
Technical data							
Nominal power (Gas models)	7.7 kW	7.5 kW	6.8 kW	5.3kW	5.3kW	3.0kW	
Nominal power (Induction model)				14.7kW			12.6kW
Conventional kW/h (main oven)	1.13 kW/h	0.86 kW/h	1.13 kW/h	0.82kW/h	0.86kW/h	1.13kW/h	1.13kW/h
Conventional kW/h (auxiliary oven)	0.85 kW/h	0.91 kW/h	0.70 kW/h	0.59kW/h	0.59kW/h		
Forced air convection kW/h (main)	0.99 kW/h	0.75 kW/h	0.99 kW/h	0.75kW/h	0.75kW/h	0.99kW/h	0.99kW/h
Forced air convection kW/h (auxiliary)	0.79 kW/h	0.79 kW/h					
Standard Accessories Main oven							
Roasting/Grill pan	•	•	•	•	•	•	•
Grill Mesh	•	•		•	•	•	•
Chrome Shelf	2	•	2	•	•	2	2
Non-Stick tray	•		•			•	•
Rotisserie kit	•	•	•			•	•
Roof Liner		•		•	•		
Enamelled tray		•			•		
Wok Support			•			•	
Stay clean liners	•	•	•		•	•	
Standard Accessories Auxiliary oven							
Roasting/Grill pan	•	•	•	•	•		
Grill Pan Handle				•	•		
Grill Mesh	•	•	•	•	•		
Chrome Shelf	•	•	•	•	•		
Rotisserie kit				•	•		
Pizza Stone	•	•					
Pizza Shovel	•	•					
Roof Liner	•	•		•	•		
Enamelled tray							
Stay clean liners	•	•					
Optional Extras							
Splashback (Stainless steel)	KIT1A5-5	KIT1A3-6	KIT1A3-6	KIT1CSP20	KIT1A2-6	KIT1A1-6	KIT1CSP19
Splashback (Polished St/steel - to match black models)					KIT1A2SE6	KIT1A1SE6	
Kickplate (Stainless steel)	KIT2A5-5	KIT2A4-8	KIT2A3-2	KIT2A2-8	KIT2A2-8	KIT2A1-2	KIT2A1-2
Kickplate (Gloss Black)		KIT2A4BL8			KIT2A2BL8	KIT2A1N-6	
Kickplate (Cream)						KIT2A1P-2	
Chimney hood (Stainless steel)	KD150X-2	KD120X-2	KD120X-2	KD100X-2	KD100X-2	KD90X-2	KD90X-2
Chimney hood (Gloss black)					KD100N-2	KD90N-2	
Chimney hood (Cream)						KSED95P-9	
Height extension kit (Stainless steel) - extra 5cm	KIT3-6	KIT3-6	KIT3-6	KIT3-6	KIT3-6	KIT3-6	KIT3-6
Height extension kit (Gloss black)		KIT3N6			KIT3N6	KIT3N6	
Deep kickplate (Stainless steel)	KIT4A5-5	KIT4A4-8	KIT4A3	KIT4A2-8	KIT4A2-8	KIT4A1	KIT4A1-2
Deep kickplate (Gloss black)		KIT4A4BL8			KIT4A2BL8	KIT4A1N-6	
Telescopic shelf set (Total extraction)	GT1T	GT1T	GTA-6	GT1T	GT1T	GTA-6	GTA-6
Telescopic shelf set (Partial extraction)	GT1P	GT1P		GT1P	GT1P		
Plate rack (auxiliary oven)			PR9A3	PR7A2	PR7A2		
Wok Support (Gas Model)	WOKGHU	WOKGHU	WOKGHU	WOKGHU	WOKGHU	WOKGHU	
Teppanyaki grill plate (gas hobs)	TPKX	TPKX	TPKX	TPKX	TPKX	TPKX	
Cast iron open griddle	GO120	GO120	GO120				
Cast iron ribbed griddle	GC120	GC120	GC120				
Pizza stone	PRTX	PRTX	PRTX	PRTX	PRTX	PRTX	PRTX
Pizza shovel	PALPZ	PALPZ	PALPZ	PALPZ	PALPZ	PALPZ	PALPZ

SYMPHONY COOKERS

	SY4110	SY92IPX8	SY92PX8	SY62MX8	SY6CPX8
Colour Options (Gas Hob)					
Stainless Steel	SY4110-8			SY62MX8	
Stainless Steel (pyrolytic cleaning)			SY92PX8		
Black	SY4110BL8				
Colour Option (Ceramic or Induction Hob)					
Stainless Steel (pyrolytic cleaning)		SY92IPX8			SY6CPX8
Technical data					
Main oven net capacity (litres)	60	68	68	60	68
Auxiliary oven net capacity (litres)	60	27	27	27	
Grill compartment	27				
Nominal power	8.7 kW	15.8kW	5.2kW	5.4kW	10.4kW
Conventional kW/h (main oven)	0.79 kW/h	0.84kW/h	0.84kW/h	0.80kW/h	0.84kW/h
Conventional kW/h (auxiliary oven oven)	0.79 kW/h	0.59kW/h	0.59kW/h	0.59kW/h	
Forced air convection kW/h (main)	0.80 kW/h	0.88kW/h	0.88kW/h	0.69kW/h	0.88kW/h
Standard Accessories Main oven					
Roasting/Grill pan	•	•	•	•	•
Extra deep tray	•	•	•	•	•
Grill Mesh	•	•	•	•	•
Chrome Shelf	•	•	•	•	•
Non-Stick tray	•				
Telescopic shelf		GTIP	GTIP	GTIP	GTIP
Rotisserie kit		•	•	•	•
Roof Liner	•	•	•	•	•
Wok Support					
Standard Accessories Auxiliary oven					
Roasting/Grill pan	•	•	•	•	•
Grill Mesh	•	•	•	•	•
Chrome Shelf	•	•	•	•	•
Enamelled tray	•				
Roof Liner	•			•	
Cooker base & height					
Fixed plinth at base (cooker height 900mm)	•			•	
4 St/steel legs (cooker height 880-915mm) or optional plinth (cooker height 900mm)		•	•		•
Optional Extras					
Splashback (Stainless steel)	KITS110X8	KITC9X	KITC9X	KITC6X	KITC6X
Chimney hood (Stainless steel)	KSE110X	K90X/KFV90	K90X/KFV90	KFV60	KFV60
Chimney hood (Gloss black)	KSE110BL				
Teppanyaki grill plate	TBX6090		TBX6090	TBX6090	
Telescopic shelf set (Total extraction)	GT1T	GT1T	GT1T	GT1T	GT1T
Telescopic shelf set (Partial extraction)	GT1P	GT1P	GT1P	GT1P	GT1P
Plate rack (auxiliary oven)		PR7A2	PR7A2		
Wok Support	WOKGHU		WOKGHU	WOKGHU	
Stay clean liners (Main)	PC60			PC60	
Pizza stone	PRTX	PRTX	PRTX	PRTX	PRTX
Pizza shovel	PALPZ	PALPZ	PALPZ	PALPZ	PALPZ

HIGH POWERED COOKERS

When selecting an appliance with a nominal power in excess of 7.2kW, a qualified electrician should be consulted to check the suitability of the circuit within the property where the connection is intended to be made. Recent wiring developments can allow larger high powered appliances to be installed safely in homes by experts. All such appliances must be installed by a qualified electrician.

CONCERT COOKERS

	SUK92	SUK91	SUK81	SUK62	SUK61	SUK61
Colour Options (Gas Hob)						
Stainless Steel	SUK92MX8	SUK91MFX7	SUK81MFX5	SUK62MX8		SUK61MX8
Stainless Steel (pyrolytic cleaning)					SUK61PX8	
Black	SUK92MBL8	SUK91MBL7	SUK81MBL5	SUK62MBL8		SUK61MBL8
Cream	SUK92MP9					
Colour Option (Ceramic Hob)						
Stainless Steel	SUK92CMX8	SUK91CMX7		SUK62CMX8		
Black	SUK92CBL8			SUK62CBL8		
Technical data						
Main oven net capacity (litres)	60	109	78,5	60	68	68
Auxiliary oven net capacity (litres)	27			27		
Nominal power (Gas hob)	4.3kW	4.1kW	3.0kW	5.4kW	3.0kW	3.0kW
Nominal power (ceramic hob)	13.3kW	13.4kW		12.8kW		
Conventional kW/h (main oven)	0.80kW/h	1.19kW/h	1.15kW/h		0.84kW/h	0.83kW/h
Conventional kW/h (auxiliary oven)	0.59kW/h			0.59kW/h		
Forced air convection kW/h (main)	0.69kW/h	1.25kW/h	0.99kW/h	0.59kW/h	0.88kW/h	0.74kW/h
Standard Accessories Main oven						
Roasting/Grill pan	•	•	•		•	
Extra deep tray	•			•	•	•
Grill Pan Handle						
Grill Mesh	•	•	•	•	•	•
Chrome Shelf	•	•	•	•	•	•
Non-Stick tray		•	•			
Telescopic shelf						
Rotisserie kit		•	•			
Roof Liner	•					
Wok Support (gas hob models only)	•			•	•	•
Standard Accessories Auxiliary oven						
Grill Mesh	•			•		
Chrome Shelf	•			•		
Non-Stick tray	•			•		
Roof Liner				•		
Cooker base & height						
Fixed plinth at base (cooker height 900mm)		•	•	•		
4 St/steel legs (cooker height 880-915mm) or optional plinth (cooker height 900mm)	•				•	•
Optional Extras						
Splashback (Stainless steel)	KIT90X	KIT90X		KIT60X	KIT60PX	KIT60X
Chimney hood (Stainless steel)	KSED95X-1	KSED95X-1		KSED65X-1	KSED65X-1	KSED65X-1
Chimney hood (Cream)	KSED95P-9					
Teppanyaki grill plate (gas models only)	TBX6090	TBX6090	TBX6090	TBX6090	TBX6090	TBX6090
1 level telescopic shelf (total extraction)	GTIT			GTIT	GTIT	GTIT
2 level telescopic shelf (partial extraction)	GT1P			GT1P	GT1P	GT1P
Plate rack (auxiliary oven)	PR7A2					
Wok Support (gas models only)	WOKGHU	WOKGHU	WOKGHU	WOKGHU	WOKGHU	WOKGHU
Stay clean liners (Main)	PC60			PC60		PC68
Pizza stone	PRTX	PRTX	PRTX	PRTX	PRTX	PRTX
Pizza shovel	PALPZ	PALPZ	PALPZ	PALPZ	PALPZ	PALPZ

HIGH POWERED COOKERS

When selecting an appliance with a nominal power in excess of 7.2kW, a qualified electrician should be consulted to check the suitability of the circuit within the property where the connection is intended to be made. Recent wiring developments can allow larger high powered appliances to be installed safely in homes by experts. All such appliances must be installed by a qualified electrician.

COOKER SELECTION AT A GLANCE



Cooker width	Model no	FINISH			HOB TYPE			NO. OF OVENS			MAIN OVEN pyrolytic cleaning
		stainless steel	gloss black	gloss cream	gas	induction	ceramic	1	2	3	
OPERA RANGE											
150cm	A5-8	•			•					•	
120cm	A4-8	•			•					•	
	A4BL-8		•		•					•	
	A3-7	•			•					•	
100cm	A2PYID-8	•			•	•				•	•
	A2PY-8	•			•					•	•
	A2-8	•			•					•	
	A2BL-8		•		•					•	
90cm	A1PYID-7	•			•	•				•	•
	A1-7	•			•					•	
	A1BL-7		•		•					•	
	A1P-9			•	•					•	
SYMPHONY RANGE											
110cm	SY4110-8	•			•						•
	SY4110BL8		•		•						•
90cm	SY92IPX8	•			•	•				•	•
	SY92PX8	•			•					•	•
60cm	SY62MX8	•			•					•	
	SY6CPX8	•			•		•	•			•
CONCERT RANGE											
90cm	SUK92MX8	•			•					•	
	SUK92MBL8		•		•					•	
	SUK92MP9			•	•					•	
	SUK92CMX8	•					•			•	
	SUK92CBL8		•				•			•	
	SUK91MFX7	•			•			•		•	
	SUK91MBL7		•		•			•		•	
	SUK91CMX7	•					•			•	
80cm	SUK81MFX5	•			•					•	
	SUK81MBL5		•		•					•	
60cm	SUK62MX8	•			•					•	
	SUK62MBL8		•		•					•	
	SUK62CMX8	•					•			•	
	SUK62CBL8		•				•			•	
	SUK61PX8	•			•					•	•
	SUK61MX8	•			•					•	
	SUK61MBL8		•		•					•	



GLASS SPLASHBACKS

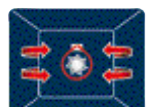

DIMENSIONS	60cm W x 75cm H	75cm W x 75cm H	75cm W x 32cm H	90cm W x 75cm H	2 x 100cm W x 14cm H
GLASS COLOUR	MODEL NOS	MODEL NOS	MODEL NOS	MODEL NOS	MODEL NOS
BLACK	SPG6075NE	SPG7575NE	SPG7532NE	SPG9075NE	UPGNE
CREAM	SPG6075P			SPG9075P	UPGP
RED	SPG6075R			SPG9075R	UPGR
PASTEL BLUE	SPG6075AZ			SPG9075AZ	UPGAZ
LIME	SPG6075VE			SPG9075VE	UPGVE
SILVER	SPG6075S	SPG7575S		SPG9075S	UPGS
MATT WHITE	SMG6075B	SMG7575B	SMG7532B	SMG9075B	UMGB
MATT BLACK	SMG6075NE	SMG7575NE	SMG7532NE	SMG9075NE	UMGNE



UPSTANDS



OVEN FUNCTIONS



  **Circulaire:**
The combination of the fan and circular element around it gives a hot air cooking method. This provides many benefits including no preheat if cook time is more than 20 minutes, no flavour transfer when cooking different foods at the same time, less energy, and shorter cook times. Good for all types of food.



  **Circulaire with upper and lower elements:**
The use of the fan with both elements allows food to be cooked quickly and effectively, ideal for large joints that require thorough cooking. It offers a similar result to rotisserie, moving the heat around the food, instead of moving the food itself, enabling any size or shape to be cooked.



  **Circulaire with lower element:**
The addition of the lower element adds extra heat at the base for food which requires extra cooking.



  **Circulaire with upper element:**
Similar to fan with upper element with the added cooking speed of circulaire, ideal for dishes with a crispy topping.



  **Upper and lower element only:**
A traditional cooking method best suited for single items located in the centre of the oven. The top of the oven will always be hottest. Ideal for roast, fruit cakes, bread etc.

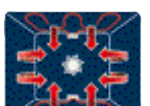

  **Lower heating element only:**
Ideal for foods that require extra base temperature without browning, e.g. pastry dishes, pizza. Also suitable for slow cooking of stews and casseroles.

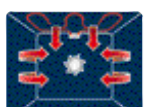

  **Top element only:**
Useful for browning the tops of dishes such as lasagne and potato or cheese topped recipes.

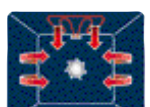

   **Grill element/Half grill:**
For rapid cooking and browning of foods. Best results can be obtained by using the top shelf for small items, the lower shelves for larger ones, such as chops or sausages. For half grill heat is generated only at the centre of the element, so is ideal for smaller quantities.

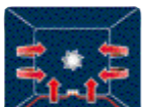

  **Fan with upper and lower elements:**
The elements combined with the fan aim to provide more uniform heat, a similar method to conventional cooking, so pre-heat is required. Most suitable for items requiring slow cooking methods.

  **Fan with upper element:**
The same functionality as top element only but will distribute the heat around the cavity allowing for plate warming etc at the same time.

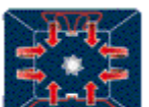
   **Fan with grill element:**
The fan reduces the fierce heat from the grill, providing an excellent method of grilling various foods, chops, steaks, sausages etc. giving even browning and heat distribution, without drying out the food. The top two levels recommended for use, and the lower part of the oven can be used to keep items warm at the same time, an excellent facility when cooking a grilled breakfast. Half grill (centre portion only) is ideal for small quantities of food.



  **Fan with lower element:**
This combination completes cooking more quickly of foods that are ready on the surface, but require more cooking inside, without further browning.



  **Pizza function:**
The simultaneous operation of these three elements ensures an optimum cooking facility when used with the Smeg pizza stone.

  **Defrost:**
Both symbols refer to the same function. The circulation of air enables quicker thawing of frozen food, without the use of any heat. Ideal for use prior to cooking of ready-made dishes, or cream filled products etc.

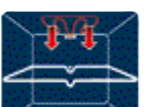
 **Snowflake:**
With the switch on this symbol, no heating is possible even if the thermostat is turned.

 **Fan:**
As above but with thermostat set a '0'.

  **Rotisserie:**
The rotisserie (where installed) works in combination with the grill element whilst constantly turning the food.

  These symbols allow use of the rotisserie with full or half grill.

 This symbol adds top heat to cook food more quickly.

 **Eco:**
The Eco setting is a fast preheat function, which combines grill, fan and lower element to achieve optimum energy efficiency. Only to be used prior to selecting the main cook function.

Quality, Environmental and Occupational Health & Safety Management Systems

All Smeg factories are ISO9001, ISO14001 and OHSAS 18001 certified, ensuring that the highest standards of quality are continually maintained whilst actively responding to all environmental issues relating to manufacture. The materials and components used to produce smeg products undergo strict quality control testing, and care is taken to source recyclable materials wherever possible. These management systems enable Smeg to provide complete assurance that all products meet superior standards whilst respecting the environment. The workforce is not forgotten – the occupational health and safety assessment scheme promotes a safe and healthy working environment, aids legislative compliance and helps improve overall performance.



UNI EN ISO 9001



UNI EN ISO 14001



OHSAS 18001

Whereas every effort has been made to ensure that the information contained in our literature is correct at time of going to print, this brochure should not be regarded as an infallible guide to current specification, nor does it constitute an offer for sale of any particular product.