

Smeg philosophy

Distinctive domestic appliances developed in collaboration with leading architects of the world. Products that express "Made in Italy" style by perfectly combining design, performance, and attention to detail. Smeg. Technology with style.

OVERVIEW	2
50'S RETRO STYLE	6
ST/STEEL	18
SIDE BY SIDE	21
CHARTS AND FUNCTIONS	22



Smeg was established in 1948 as an enamelling plant, working with metals; the acronym of Smeg (Smalterie Metallurgiche Emiliane Guastalla) serves as a memory of the initial activity carried out by the Company.

FREESTANDING FRIDGES, EXUDING STYLE



All Smeg free standing fridges are designed to enhance the environment they inhabit. Their lines, colours and materials blend beautifully with other furniture, lending a touch of style and prestige. The wide choice of different materials and colour effects can meet all sorts of tastes and bring originality and personality to any space.

GIVE PERSONALITY TO THE KITCHEN

Smeg fridges are more than just a commodity, freestanding refrigeration models are available in a **vast range of styles**, from contemporary stainless steel to bold retro aesthetics. They make a statement in any kitchen or perfectly complete a modern minimal design. Distinctive "Classic" style handles on some models coordinate well with many other "Classic" Smeg products.



ST/STEEL EFFECT

St/steel effect refrigerators have been added to the range which all have a flat door creating clean lines and an understated design. One of these, the FC34XPNF, also features a handle-less door design, further enhancing the simplicity and sleekness of these products.



SIDE-BY-SIDE

Smeg offers an American-style **side-by-side** fridge whose versatile dimensions are combined with the sort of elegance that is so typical of Italian design.



50'S RETRO STYLING

Beautiful bold finishes and soft round curves reminiscent of 1950's retro design, there are many colour options to choose from in the iconic Smeg FAB range from stylish white to vibrant red.

NEW FAB10 HOME BAR, THE ULTIMATE IN DRINKS STORAGE



New to the iconic FAB range is the FAB10 Home Bar. Developed by an intuition that goes beyond the traditional concept of a mini-fridge, the Home Bar has an innovative interior that maximises storage space within the appliance. The internal space is so flexible. There is specific housing for bottles, which can be placed either vertically or horizontally and there are shelves dedicated to housing cans, ensuring perfect placement of each type of drink. Available in a choice of three colours; Red, Cream or Black, which can add a splash of colour to your kitchen and create a cool and contemporary look.

SUPERB CRAFTSMANSHIP

Over the years Smeg have accumulated solid know-how and expertise to produce innovative appliances both in terms of design and technology. The interiors are designed to allow full use of the space available, and include numerous internal storage compartments, such as chiller sections and ice dispensers.

ADVANCED TECHNOLOGY

Features and performance



This compartment is ideal for keeping fish, meat, dairy products and other highly perishable foods fresh. The extra fresh compartment maintains a constant temperature between just above 0°C and +5°C, keeping the food fresher for longer.



AIR PLUS which keeps food fresher for longer. A fan in the refrigerator distributes cool air through vents to provide even cooling throughout the refrigerator, and returns the temperature to its optimum level quickly after the door has been opened.



The **Frost-free** refrigeration system ensures dry conditions by forced air circulation throughout the interior, moving between the freezer and refrigerator and preventing ice from forming on the sides. The flow of air can allow extra cool compartments in the refrigerator, useful for storing perishable items longer than usual.



In **No Frost** appliances forced air is circulated through the fridge and freezer sections separately using 2 evaporators, preventing ice forming on the sides. No Frost products have the most energy efficient frost prevention system where energy is not wasted unnecessarily, so they are more cost effective and efficient to run through the lifetime of the appliance.



The **FAST FREEZING** option is particularly useful when you want to freeze a large quantity of fresh food. Activating the fast freeze function a couple of hours before introducing the fresh food means that the freezer gets ready to work on full power, bringing the temperature right down.



The **AUTOMATIC DEFROST** system is a time saving device that works by automatically defrosting at regular intervals eradicating the need to defrost altogether.



Some refrigerators feature **LED INTERIOR LIGHTING** which illuminates the interior of the appliance. LED lighting is more energy efficient and lasts longer than traditional bulbs.



The **POWER SAVING MODE** is particularly useful in cases of prolonged absence from home such as holidays, as it allows you to disable the refrigerator and keep the freezer working which saves electricity.



Excellent insulation and special devices, specifically designed to muffle the sound generated during operation, keeps the noise to a minimum for maximum comfort in the environment.

Respect for the Environment



All Smeg refrigerators and freezers have at least an A+ energy rating. The major drive for innovation has made it possible for some models to achieve even greater energy efficiency, with an A++ rating. Ever sensitive to the need to safeguard the environment, Smeg has been offering highly reliable models for many years that are completely free of CFCs and HFCs, the gasses responsible for the hole in the ozone layer.

EXPLAINING THE EU ENERGY LABEL

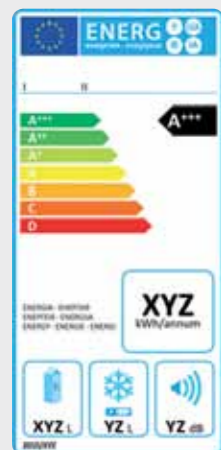

The new EU energy label provides consumers with accurate, recognisable and comparable information on domestic household products regarding energy consumption, performance and other essential characteristics. EU energy labels provide all the essential product information, particularly energy consumption, to enable consumers to compare products before purchase.

The revised labels now include:

- Energy rating from A+++ to D
- Annual energy consumption in kWh
- Capacity of all storage compartments in litres
- Capacity of frozen food storage compartments in litres
- Noise emissions in decibels

Revised European legislation introduced energy ratings up to A+++ to further differentiate between already energy efficient models and those incorporating the latest technological developments. For more information please visit www.newenergylabel.com.

SIDE-BY-SIDE: AMPLE SPACE



The American style side-by-side refrigerator-freezer offers a number of special features: an ice and water dispenser integrated elegantly into the door has been designed so that as much space as possible remains inside the freezer compartment. A modern LCD display makes it possible to adjust the functions selected and regulate the interior temperature settings without opening the door. This has a significant energy saving and a lower cooling loss.



EXTENDING THE REFRIGERATION SPACE



New to the Smeg freestanding refrigeration range are the UK26PXNF3 and UK35PX3. These appliances can be positioned side by side in order to create a large refrigeration space that maximises food storage capabilities.



The Freezer is also No Frost which means it does not require defrosting, a very handy feature.

A number of FAB28's and CVB20's (in Cream, Red, Orange and Black) can also be positioned next to each other to create the same effect.

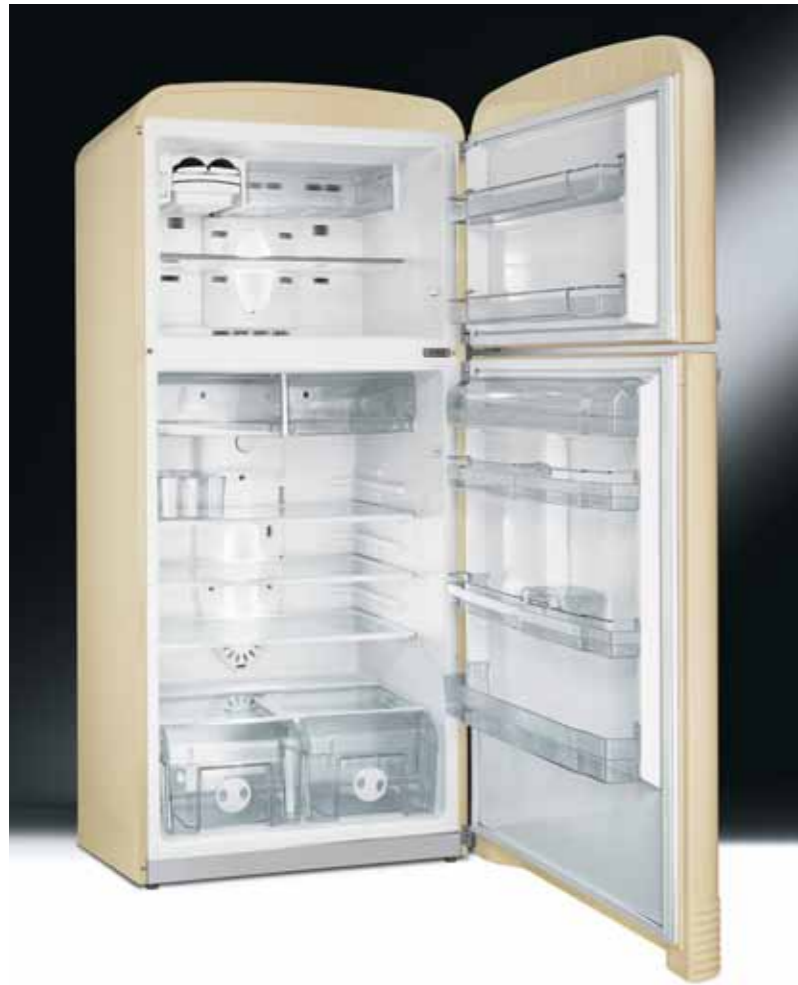

Gross capacity: 484 litres
 1 compressor
 2 adjustable thermostats
 Noise level: 43 dB(A) RE 1 pW

REFRIGERATOR:
 Fresh food capacity: 362 litres
 2 chiller compartments
 Automatic defrost
 3 adjustable glass shelves
 1 fixed glass shelf
 2 fruit & vegetable compartments

FREEZER: ****
 Frozen food capacity: 107 litres
 Manual ice making facility
 1 fast freezing compartment
 Completely frost free

All codes shown are right hand hinged.
 For left hand hinges add the letter S to the end of the code,
 ie FAB50PS

NB: These models are only available from selected
 dealers. For stockist details please see the website
www.smeguk.com.



FAB50B
White



FAB50X
Silver

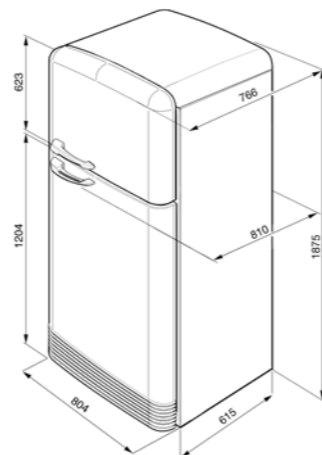

When positioning these appliances adjacent to a wall
 or kitchen unit a gap of 200mm must be left to allow the
 door to open.

For additional information see pages 22-23



FAB50B

FAB32RNR

50's RETRO STYLE REFRIGERATION-FREEZER, RED



FAB32RNC Cream



FAB32RNN Black

NO FROST VERSION



Gross capacity: 328 litres
2 adjustable thermostats
Noise level: 41 dB(A) RE 1 pV

REFRIGERATOR:

Fresh food capacity: 229 litres
Automatic defrost
3 adjustable glass shelves
1 fruit and vegetable container
1 covered storage box
1 chrome wine rack

FREEZER: ****

Frozen food capacity: 75 litres
2 drawers
1 fast freezing drawer
Ice cube tray

ONLY AVAILABLE IN THE FOLLOWING COLOURS:

Red FAB32RNR
Cream FAB32RNC
Black FAB32RNN

All codes shown are right hand hinged.
For left hand hinges replace R in code with L,
i.e FAB32LNR

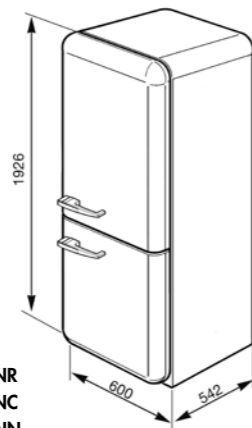

FAB32RNR
FAB32RNC
FAB32RNN

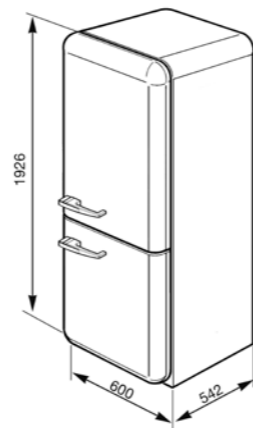

FAB32RFR
FAB32RFC
FAB32RFG
FAB32RFA
FAB32RFN
FAB32RFL
FAB32RFP

When positioning these appliances adjacent to a wall or kitchen unit a gap of 175mm must be left on the hinged side of the product to allow the door to open.

FAB32RFR

50's RETRO STYLE REFRIGERATOR-FREEZER, RED



FAB32RFC Cream



FAB32RFG Pastel Green



FAB32RFA Pastel Blue



FAB32RFN Black

FANNED VERSION



Gross capacity: 342 litres
2 adjustable thermostats
Noise level: 41 dB(A) RE 1 pV

REFRIGERATOR:

Fresh food capacity: 229 litres
Automatic defrost
3 adjustable glass shelves
1 fruit and vegetable container
1 covered storage box
1 chrome wine rack

FREEZER: ****

Frozen food capacity: 92 litres
2 drawers
1 fast freezing drawer

All codes shown are right hand hinged.
For left hand hinges replace R in code with L,
i.e FAB32LFR



FAB32RFL Lime Green



FAB32RFP Pink

FAB30RFC

50's RETRO STYLE REFRIGERATOR-FREEZER, CREAM



Gross capacity: 295 litres
Fast cooling switch
Noise level: 38 dB(A) RE 1 pW

REFRIGERATOR:
Fresh food capacity: 229 litres
Automatic defrost
3 adjustable glass shelves
1 fruit and vegetable container
1 covered storage box
1 chrome wine rack

FREEZER: ********
Frozen food capacity: 64 litres
1 adjustable shelf with ice cube tray

All codes shown are right hand hinged.
For left hand hinges replace R in code with L, i.e FAB30LFO

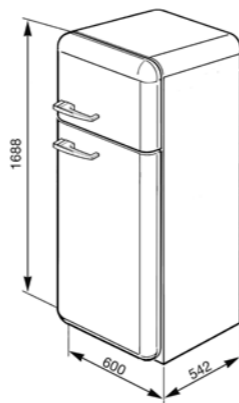

When positioning these appliances adjacent to a wall or kitchen unit a gap of 175mm must be left on the hinged side of the product to allow the door to open.



FAB30RFR Red



FAB30RFS Silver



FAB30RFP Pink



FAB30RFA Pastel Blue



FAB30RFG Green



FAB30RFO Orange



FAB30RFB Blue



FAB30RFN Black



FAB30RFL Lime Green

FAB28QP1

50's RETRO STYLE REFRIGERATOR WITH ICE COMPARTMENT, CREAM



Gross capacity: 256 litres
Tropicalized compressor
Climatic selector switch
Noise level: 39 dB(A) RE 1 pW

REFRIGERATOR:
Fresh food capacity: 222 litres
Automatic defrost
3 adjustable glass shelves
1 fruit and vegetable container
1 chrome wine rack

ICE BOX: ❄️❄️❄️❄️
Frozen food capacity: 26 litres
Ice cube tray

All codes shown are right hand hinged.
For left hand hinges replace Q in code with Y, i.e FAB28YB1

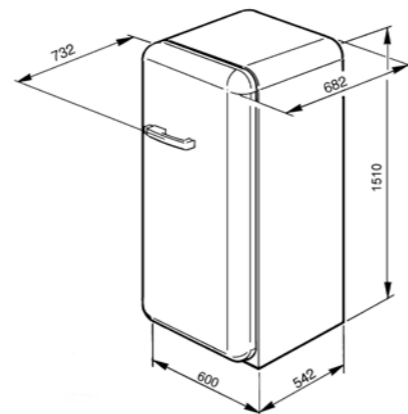

When positioning these appliances adjacent to a wall or kitchen unit a gap of 175mm must be left on the hinged side of the product to allow the door to open.

For additional information see pages 22-23



FAB28QG1 Yellow



FAB28QVE1 Lime Green



FAB28QO1 Orange



FAB28QNE1 Black



FAB28QRO1 Pink



FAB28QX1 Silver



FAB28QR1 Red



FAB28QBL1 Blue



FAB28QAZ1 Pastel Blue



FAB28QB1 White



FAB28QV1 Pastel Green

FAB28QCS1 SPECIAL EDITION

50's RETRO STYLE REFRIGERATOR WITH ICE COMPARTMENT,
COLOUR STRIPE



Gross capacity: 256 litres
Tropicalized compressor
Climatic selector switch
Noise level: 40 dB(A) RE 1 pW

REFRIGERATOR:
Fresh food capacity: 222 litres
Automatic defrost
3 adjustable glass shelves
1 fruit and vegetable container
1 chrome wine rack

ICE BOX: ❄️❄️❄️❄️
Frozen food capacity: 26 litres
Ice cube tray



FAB28QUJ1
Union Jack

FAB28RDB LIMITED EDITION

50's RETRO STYLE REFRIGERATOR WITH ICE COMPARTMENT,
DENIM

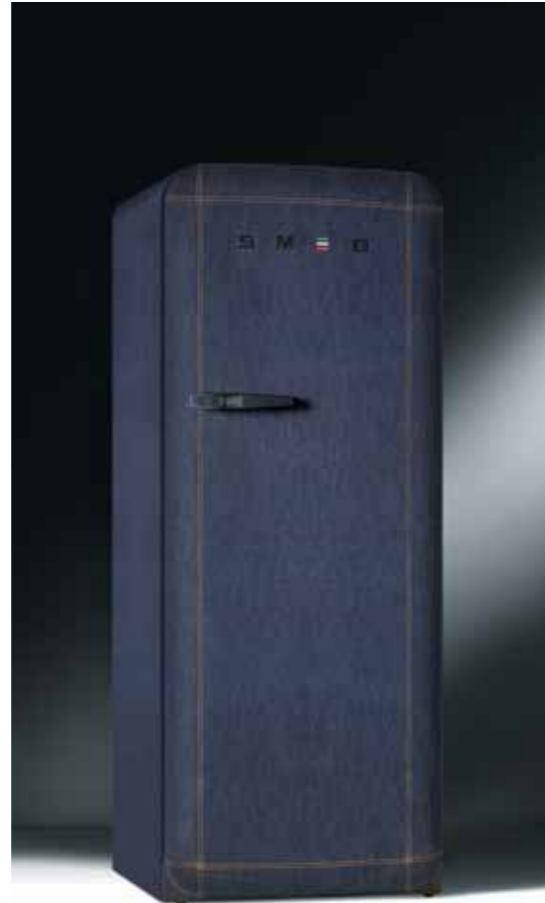

MODELS PICTURED ARE RIGHT HAND HINGED.

ALSO AVAILABLE WITH LEFT HAND HINGES:-
Colour stripe **FAB28YCS1**
Union Jack **FAB28YUJ1**

NB: The fabric of the Denim fridge, has been treated with PLASMA, a nano-technology, which protects the surface of the fridge from splashes of water, oil, milk and fruit juices.
The Denim FAB is **only available right hand hinged**.

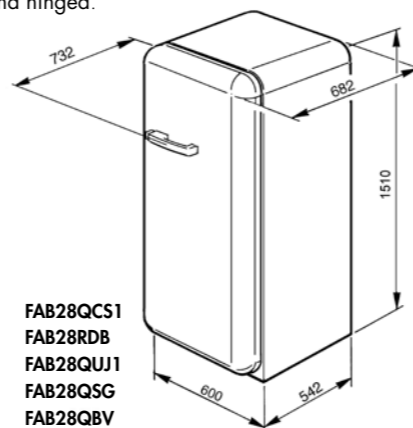

FAB28QCS1
FAB28RDB
FAB28QUJ1
FAB28QSG
FAB28QBV

When positioning these appliances adjacent to a wall or kitchen unit a gap of 175mm must be left on the hinged side of the product to allow the door to open.

FAB28QSG SPECIAL EDITION

50's RETRO STYLE REFRIGERATOR WITH ICE COMPARTMENT,
ENGLAND FLAG



Gross capacity: 256 litres
Tropicalized compressor
Climatic selector switch
Noise level: 40 dB(A) RE 1 pW

REFRIGERATOR:
Fresh food capacity: 222 litres
Automatic defrost
3 adjustable glass shelves
1 fruit and vegetable container
1 chrome wine rack

ICE BOX: ❄️❄️❄️❄️
Frozen food capacity: 26 litres
Ice cube tray

ALSO AVAILABLE WITH LEFT HAND HINGES:-
England Flag **FAB28YSG**

FAB28QBV LIMITED EDITION

50's RETRO STYLE REFRIGERATOR WITH ICE COMPARTMENT,
BLACK VELVET



Gross capacity: 256 litres
Tropicalized compressor
Climatic selector switch
Noise level: 40 dB(A) RE 1 pW

REFRIGERATOR:
Fresh food capacity: 222 litres
Automatic defrost
3 adjustable glass shelves
1 fruit and vegetable container
1 chrome wine rack

ICE BOX: ❄️❄️❄️❄️
Frozen food capacity: 26 litres
Ice cube tray

ALSO AVAILABLE WITH LEFT HAND HINGES:-
Black Velvet **FAB28YBV**

CVB20RR

50's RETRO STYLE UPRIGHT FREEZER, RED



CVB20RNE

50's RETRO STYLE UPRIGHT FREEZER, BLACK



CVB20RO

50's RETRO STYLE UPRIGHT FREEZER, ORANGE



Gross Capacity: 197 litres
Acoustic alarm
Noise level: 42 dB(A) RE 1 pW

FREEZER: ****
Frozen food capacity: 170 litres
Fast freezing button
2 ice cube trays
3 transparent drawers
2 transparent flaps

All codes shown are right hand hinged.
Also available with left hand hinges (L) i.e. CVB20LR

Whereas every effort is made to ensure that colours are matched, those of two adjacent appliances may seem to alter under different lighting conditions. Products dimensions should be checked when pairing a freezer with an existing fridge.

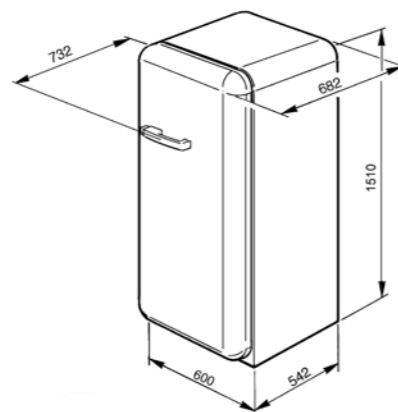

When positioning these appliances adjacent to a wall or kitchen unit a gap of 175mm must be left on the hinged side of the product to allow the door to open.

FAB10RR

50's RETRO STYLE REFRIGERATOR WITH ICE COMPARTMENT, RED



FAB10RUJ SPECIAL EDITION

50's RETRO STYLE REFRIGERATOR WITH ICE COMPARTMENT, UNION JACK



FAB10HRP HOME BAR

50's RETRO STYLE HOME BAR REFRIGERATOR, CREAM



Gross capacity: 120 litres
Climatic selector switch
Noise level: 37 dB(A) RE 1 pW

REFRIGERATOR:
Fresh food capacity: 107 litres
Automatic defrost
Adjustable thermostat
2 adjustable glass shelves
1 fruit and vegetable drawer

ICE BOX: ****
Frozen food capacity: 13 litres
Ice cube tray

All codes shown are right hand hinged.
For left hand hinges replace R in code with L, i.e. FAB10LP

CVB20RP

50's RETRO STYLE UPRIGHT FREEZER, CREAM



FAB10RP Cream
FAB10RNE Black
FAB10RO Orange

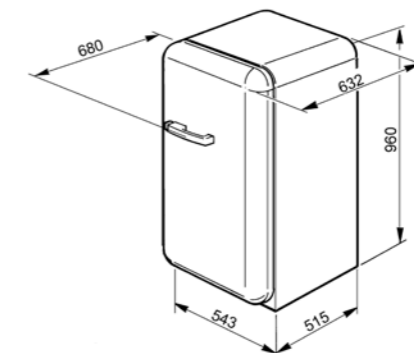

When positioning these appliances adjacent to a wall or kitchen unit a gap of 175mm must be left on the hinged side of the product to allow the door to open.



FAB10HRR Red
FAB10HRNE Black

For additional information see pages 22-23



UK26PXNF3
UK35PX3

UK26PXNF3

FREEZER WITH ST/STEEL EFFECT DOOR



Gross capacity: 265 litres
Noise level: 44 dB (A) RE 1 pW

FREEZER:
Frozen food capacity: 251 litres
5 drawers
2 shelves with flaps
Fast freeze function
Completely No Frost

Co-ordinates with UK35PX3

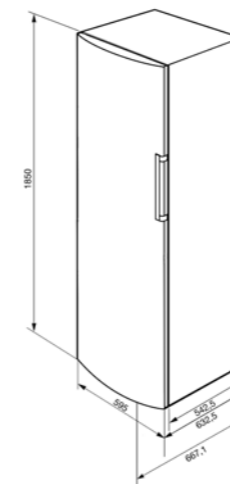

UK35PX3

UPRIGHT LARDER WITH ST/STEEL EFFECT DOOR



Gross capacity: 353 litres
Noise level: 40 dB (A) RE 1 pW

REFRIGERATOR:
Fresh food capacity: 349 litres
Automatic defrost
4 adjustable glass shelves
1 glass fruit and vegetable cover
2 fruit and vegetable containers
Comprehensive door storage

Co-ordinates with UK26PXNF3

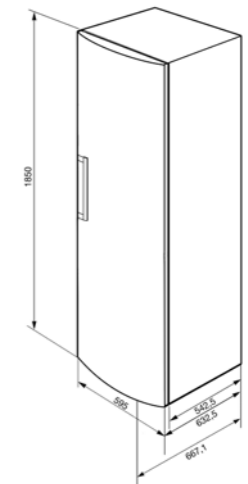

For additional information see pages 22-23

FC34XPNF

REFRIGERATOR FREEZER WITH ST/ST EFFECT DOORS



Gross capacity: 344 litres
Integrated handle
Noise level: 45 dB (A) RE 1 pW

REFRIGERATOR:

Fresh food capacity: 228 litres
Automatic defrost
3 adjustable glass shelves
1 glass fruit and vegetable cover
2 fruit and vegetable drawers

FREEZER:

Frozen food capacity: 90 litres
3 drawers
Completely No frost

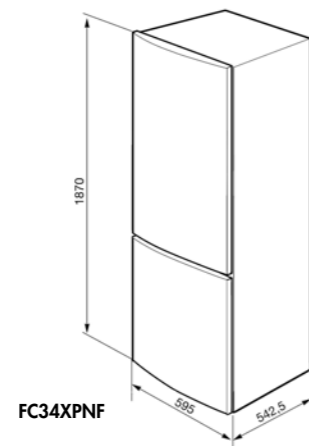

FC34XPNF

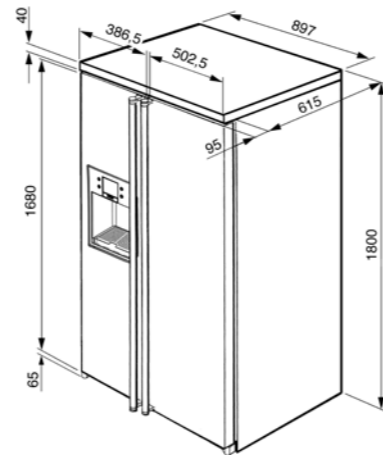

FA55PCIL3

For additional information see pages 22-23

FA55PCIL3

AMERICAN STYLE SIDE BY SIDE REFRIGERATOR-FREEZER,
FULLY CLAD IN ST/STEEL



FOR BOTH MODELS ON THIS PAGE:

Gross capacity: 600 litres
Noise level: 40 dB(A) RE 1 pW

LCD display and soft touch control panel
Ice and water dispenser
Power saving mode
Child lock function

REFRIGERATOR:

Fresh food capacity: 365 litres
"Extra Fresh" zone with soft-touch control
2 drawers with humidity control
Chrome wine rack
4 temperature sensors

FREEZER

Frozen food capacity: 173 litres
Completely frost free
Fast freeze
2 drawers
4 glass shelves
4 temperature sensors

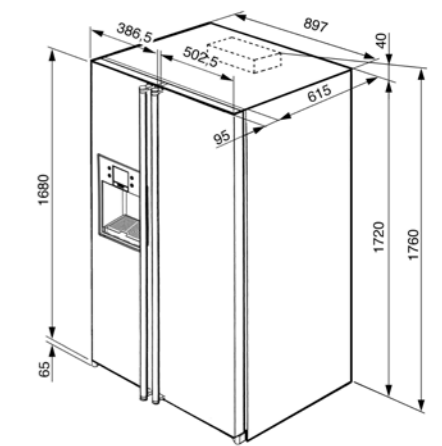
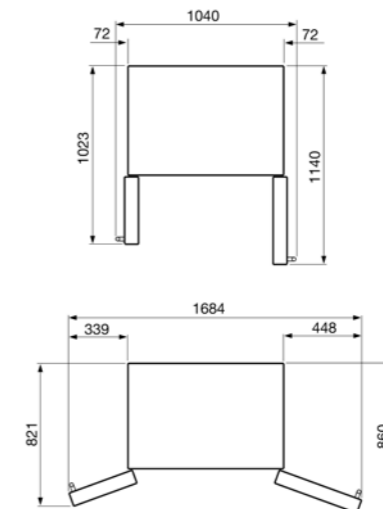

FA55XBIL3

FA55XBIL3

AMERICAN STYLE SIDE BY SIDE REFRIGERATOR-FREEZER,
ST/STEEL DOORS AND GRAPHITE SIDES



Model FA55XBIL3 can be built-in

REFRIGERATION

	Energy efficiency class	Energy consumption (Kw/h per year)	Climatic class	Freezing capacity (kg/24h)	Thaw time (h)	Reversible doors (Y/N)	Comprehensive door storage (Y/N)	Sliding rail or door-on-door fitting
Freestanding models								
FAB50	A+	419	SN-T	5	8	N	Y	N/A
FAB32 (both versions)	A++	229	SN-T	10	18	N	Y	N/A
FAB30	A++	212	SN-T	3	15	N	Y	N/A
FAB28	A++	180	N-ST	2	12	N	Y	N/A
FAB28QSG & FAB28QBV	A+	215	N-ST	2	12	N	Y	N/A
CVB20	A+	223	SN-ST	20	23	N	N	N/A
FAB10	A+	169	SN	2	10	N	N	N/A
FAB10H	A+	123	SN-T	N/A	N/A	N	Y	N/A
UK26PXNF3	A+	323	N-T	14	9	Y	N	N/A
UK35PX3	A+	150	N-T	14	8	Y	Y	N/A
FC34XPNF	A+	307	N	6	17	Y	N	N/A
FA55PCIL3	A+	461	N-T	12	5	N	Y	N/A
FA55XBIL3	A+	461	N-T	12	5	N	Y	N/A

Climatic Class

The climatic class indicates the range of ambient temperatures for which the appliance is suitable. It is important to select a refrigeration appliance specified for the environment in which it is to be situated.

Climatic Class	Min temp (°C)	Max temp (°C)
SN	10	32
N	16	32
ST	18	38
T	18	43

SYMBOLS



The cool n fresh compartment keeps food fresher for longer.



The fast freezing function brings the temperature of the compartment down when activated a few hours prior to usage.



LED interior lighting is a more energy efficient and long lasting way of illuminating the interior of the appliance.



Excellent insulation and special devices keep noise to a minimum.



The No Frost and Frost free systems prevent ice from forming so that no defrosting is required.



The automatic defrost system works by automatically defrosting at regular intervals eradicating the need to defrost altogether.



The power saving mode allows you to disable the refrigerator and keep the freezer working.



Air plus keeps food fresher for longer.

Quality, Environmental and Occupational Health & Safety Management Systems

All Smeg factories are ISO9001, ISO14001 and OHSAS 18001 certified, ensuring that the highest standards of quality are continually maintained whilst actively responding to all environmental issues relating to manufacture. The materials and components used to produce smeg products undergo strict quality control testing, and care is taken to source recyclable materials wherever possible. These management systems enable Smeg to provide complete assurance that all products meet superior standards whilst respecting the environment. The workforce is not forgotten – the occupational health and safety assessment scheme promotes a safe and healthy working environment, aids legislative compliance and helps improve overall performance.



UNI EN ISO 9001



UNI EN ISO 14001



OHSAS 18001



This catalogue is printed entirely on FSC® (Forest Stewardship Council®) certified paper that has been produced with cellulose sourced from forests that are managed responsibly, in accordance with rigorous environmental, social, economic and cultural standards.
<http://www.fsc.org/>

Whereas every effort has been made to ensure that the information and images contained in our literature are correct at time of going to print, this brochure should not be regarded as an infallible guide to current specification, nor does it constitute an offer for sale of any particular product.