



MAIN RANGE 2014-15

## Smeg philosophy

Distinctive domestic appliances developed in collaboration with leading architects of the world.

Products that express "Made in Italy" style by perfectly combining design, performance, and attention to detail.

Smeg. Technology with style.



Smeg was established in 1948 as an enamelling plant, working with metals; the acronym of Smeg (**S**malterie **M**etallurgiche **E**miliane **G**uastalla) serves as a memory of the initial activity carried out by the Company.



## Smeg Designer Collaborations

Style, for Smeg, is a distinct concept: the way a product communicates with its surroundings and enables users to interact with it.

Smeg have collaborated with established designers to produce a series of truly distinctive ovens and hobs to take centre stage in the heart of the home, offering a true statement of expression and individuality.



## PIANO DESIGN

The Piano Design Studio has applied architecture to household objects to create elegant and solid products with a refined and exclusive style. Finished with high quality polished stainless steel the Piano Design oven and hobs make a striking impact in any kitchen.

# F67-7

60CM "PIANO DESIGN" MULTIFUNCTION OVEN,  
POLISHED ST/STEEL



10 functions



- Analogue clock, with timer and cooking finish time alarm (oven switches off automatically)
- Fan for cooler touch door
- Closed door grilling
- Triple glazed door with heat reflective inner layer
- Light reflective stainless steel oven interior
- Door and oven exterior fan cooled
- Rapid heating variable grill
- Full width or 1/2 grill

Oven capacity: 53 litres

13 amp power supply required

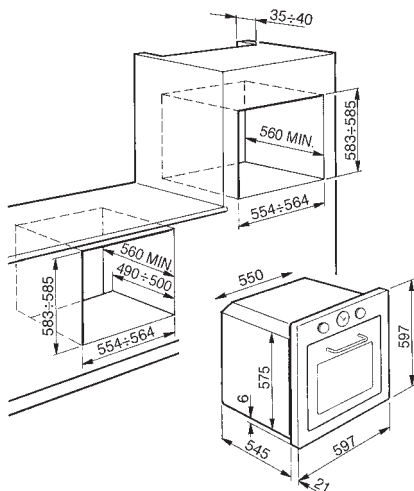

## EVERSHINE



New Piano hobs have an innovative invisible coating called Evershine. This treatment is applied to the surface of the pan stands and the tops of the burner caps to help prevent discolouration of the polished stainless steel.

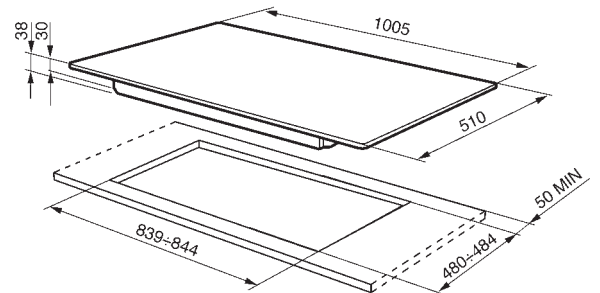

P106ES

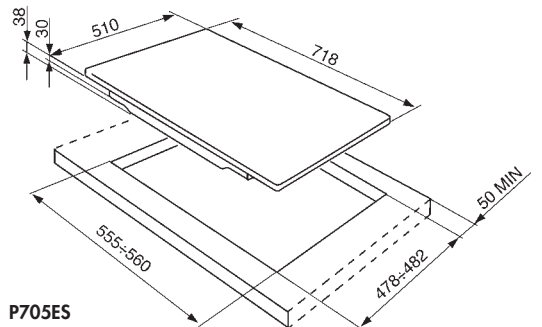

P705ES

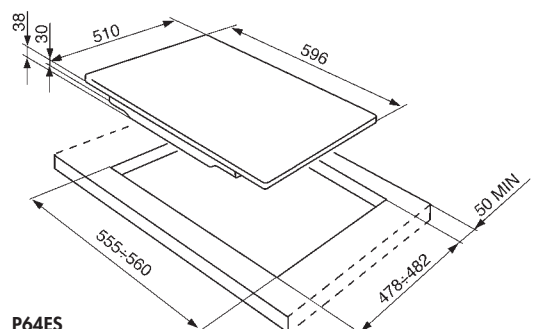

P64ES



## P106ES

100CM "PIANO DESIGN" GAS HOB, POLISHED ST/STEEL



6 burners  
 Left: Ultra Rapid burner 3.6kW  
 Centre rear left: 1.65kW  
 Centre front left: 1.0kW  
 Centre rear right: 2.3kW  
 Centre front right: 1.0kW  
 Right: Ultra Rapid burner 3.6kW

### Evershine finish

St/steel base  
 St/steel controls  
 St/steel pan stands  
 St/steel burner caps

Automatic electronic ignition  
 Safety valves  
 Adaptable for LPG



## P705ES

72CM "PIANO DESIGN" GAS HOB, POLISHED ST/STEEL



5 burners  
 Rear left: 2.3kW  
 Front left: 1.0kW  
 Centre: Ultra Rapid burner 3.6kW  
 Rear right: 1.65kW  
 Front right: 1.0kW

### Evershine finish

St/steel base  
 St/steel controls  
 St/steel pan stands  
 St/steel burner caps

Automatic electronic ignition  
 Safety valves  
 Adaptable for LPG



## P64ES

60CM "PIANO DESIGN" GAS HOB, POLISHED ST/STEEL



4 burners  
 Rear left: 2.3kW  
 Front left: 1.65kW  
 Rear right: Rapid burner 3.0kW  
 Front right: 1.0kW

### Evershine finish

St/steel base  
 St/steel controls  
 St/steel pan stands  
 St/steel burner caps

Automatic electronic ignition  
 Safety valves  
 Adaptable for LPG

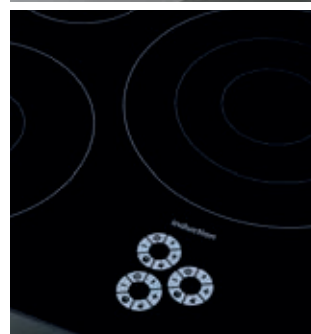

## MARC NEWSON DESIGN

Not just products, but creations. The limitless creativity of one of the most exciting designers in the world is now available as a Smeg aesthetic line. The Marc Newson product range is an excellent reflection of his signature style: that is, soft lines and extremely ergonomic designs that really make a statement in the kitchen.

# FP610AB

# PYROLITIC

60CM "MARC NEWSON" MULTIFUNCTION OVEN,  
MATT WHITE GLASS



10 functions Inc Circulaire with upper & lower element



- Digital electronic programmer with multi display
- Quadruple glazed removable cooler doors
- Removable inner door glass
- Electronic controls with child lock
- Air cooling system
- Closed door grilling**
- Rotisserie
- Pyrolitic Cleaning**
- Energy saving option - Ecologic**
- Easy clean enamel interior
- Rapid pre-heating**
- 2 halogen lamps
- Metal side supports, 5 cooking levels

Maxi plus oven GROSS capacity: 79 litres

Maxi plus oven NET capacity: 72 litres

13 Amp power supply required



FP610AN  
Matt black glass



FP610X  
St/steel

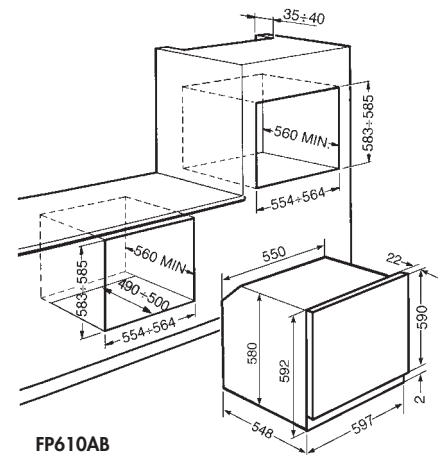

FP610AB  
F610AN  
F608X-1

## F610AN

60CM "MARC NEWSON" MULTIFUNCTION OVEN,  
MATT BLACK GLASS



11 functions Inc Circulaire with upper & lower element



- Digital electronic programmer with multi display
- Triple glazed removable doors
- Removable inner door glass
- Electronic controls with child lock
- Air cooling system
- Closed door grilling**
- Easy clean enamel interior
- Rapid pre-heating**
- 2 halogen lamps
- Metal side supports, 5 cooking levels
- Vapor clean function**

Maxi plus oven GROSS capacity: 79 litres  
Maxi plus oven NET capacity: 72 litres

13 Amp power supply required

## F608X-1

60CM "MARC NEWSON" MULTIFUNCTION OVEN,  
STAINLESS STEEL



6 functions Inc fan with upper & lower element



- Time-setting option: automatic end cooking
- Minute minder
- Double glazed removable door
- Removable inner door
- Air cooling system
- Closed door grilling**
- Easy clean enamel interior
- Interior light
- Metal side supports, 5 cooking levels

Maxi plus oven GROSS capacity: 79 litres  
Maxi plus oven NET capacity: 72 litres

13 Amp power supply required



F610X  
St/steel



F610AB  
Matt white glass



F608SB-1  
White



F608SN-1  
Black



## P755SB1

75CM "MARC NEWSON" GAS HOB, WHITE



5 burners  
 Rear left: 1.70 kW  
 Front left: 1.05 kW  
 Centre: Rapid burner 3.50 kW  
 Rear right: Rapid burner 2.60 kW  
 Front right: 1.05 kW

White enamelled base  
 Silver controls  
 Directional burners  
 Heavy duty cast iron pan stands

Automatic electronic ignition  
 Safety valves  
 Adaptable for LPG

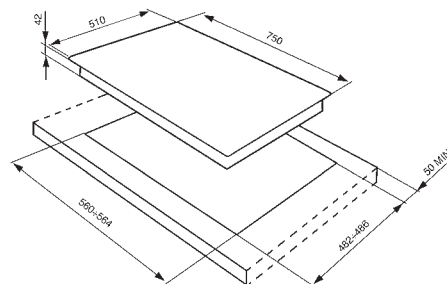

**P755X1**  
St/steel with silver controls



**P755SN1**  
Black enamel with silver controls



**P755AN1**  
Matt black glass on steel with silver controls



**P755AB1**  
Matt white glass on steel with silver controls



NB: All Marc Newson models are only available from selected dealers.  
 For stockist details please see the website [www.smeguk.com](http://www.smeguk.com)



## SI955D

90CM "MARC NEWSON" TOUCH CONTROL INDUCTION HOB WITH GREY GRAPHICS



5 zones including:  
 Rear left:  $\varnothing$  230/100mm, 2.4kW – booster 3.1kW  
 Front left:  $\varnothing$  160/100mm, 1.8kW – booster 2.2kW  
 Centre:  $\varnothing$  280/100mm, 2.8kW – booster 4.6kW  
 Rear right:  $\varnothing$  230/100mm, 2.4kW – booster 3.1kW  
 Front right:  $\varnothing$  160/100mm, 1.8kW – booster 2.2kW

Individual timers for each zone  
 15 power levels  
 Automatic pan recognition  
 Automatic safety cut-out

NB: Only pans with a ferrous (magnetic) base are suitable for induction hobs



SI955DR  
Red brick graphics



SI955DO  
Gold graphics

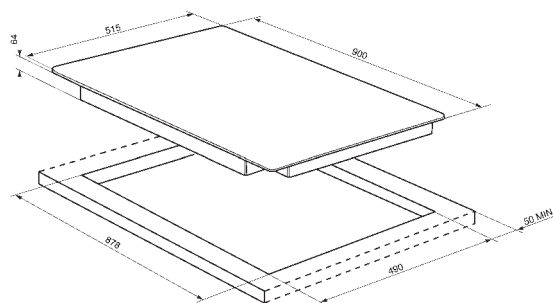

## SI933D

90CM "MARC NEWSON" TOUCH CONTROL INDUCTION HOB WITH GREY GRAPHICS



3 zones including:  
 Left:  $\varnothing$  280/100mm, 2.8kW – booster 4.6kW  
 Centre:  $\varnothing$  160/100mm, 1.8kW – booster 2.2kW  
 Right:  $\varnothing$  230/100mm, 2.4kW – booster 3.1kW

Individual timers for each zone  
 15 power levels  
 Automatic pan recognition  
 Automatic safety cut-out

NB: Only pans with a ferrous (magnetic) base are suitable for induction hobs

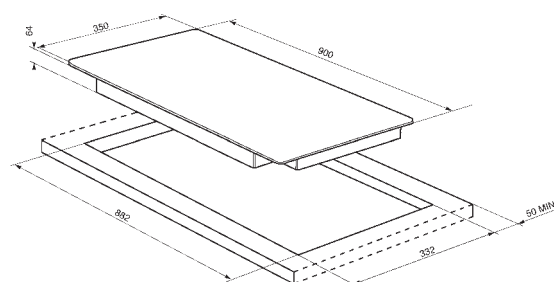



## SI733D

70CM MARC NEWSON™ TOUCH CONTROL INDUCTION HOB WITH HOB WITH GREY GRAPHICS



3 zones including:

Rear left:  $\varnothing$  160/100mm, 1.8kW – booster 2.2kW

Front left:  $\varnothing$  230/100mm, 2.4kW – booster 3.1kW

Right:  $\varnothing$  280/100mm, 2.8kW – booster 4.6kW

Individual timers for each zone

15 power levels

Automatic pan recognition

Automatic safety cut-out

NB: Only pans with a ferrous (magnetic) base are suitable for induction hobs

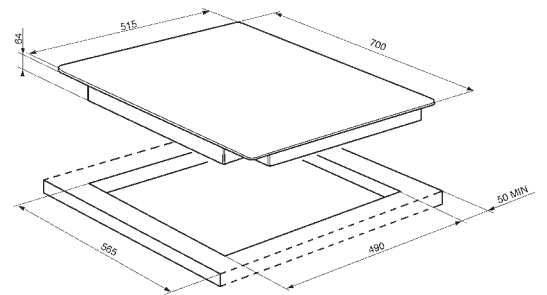

## SI644D

60CM MARC NEWSON™ TOUCH CONTROL INDUCTION HOB WITH GREY GRAPHICS



4 zones including:

Rear left:  $\varnothing$  180/100mm, 2.0kW – booster 2.8kW

Front left:  $\varnothing$  180/100mm, 2.0kW – booster 2.8kW

Rear right:  $\varnothing$  210/100mm, 2.0kW – booster 3.1kW

Front right:  $\varnothing$  160/100mm, 1.4kW – booster 2.0kW

Individual timers for each zone

15 power levels

Automatic pan recognition

Automatic safety cut-out

NB: Only pans with a ferrous (magnetic) base are suitable for induction hobs

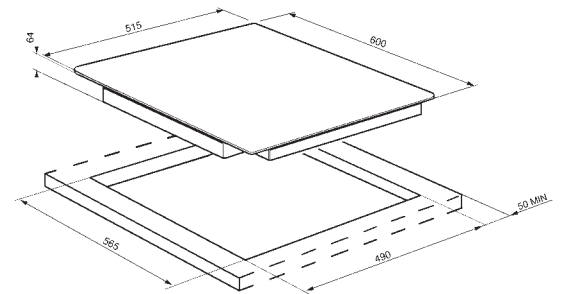

NB: All Marc Newson models are only available from selected dealers.  
For stockist details please see the website [www.smeguk.com](http://www.smeguk.com)



### SI633D

60CM MARC NEWSON™ TOUCH CONTROL INDUCTION HOB WITH GREY GRAPHICS



3 zones including:  
 Rear left: ø 160/100mm, 1.8kW – booster 2.2kW  
 Front left: ø 230/100mm, 2.4kW – booster 3.2kW  
 Right: ø 280/100mm, 2.8kW – booster 3.6kW

Individual timers for each zone  
 15 power levels  
 Automatic pan recognition  
 Automatic safety cut-out

NB: Only pans with a ferrous (magnetic) base are suitable for induction hobs

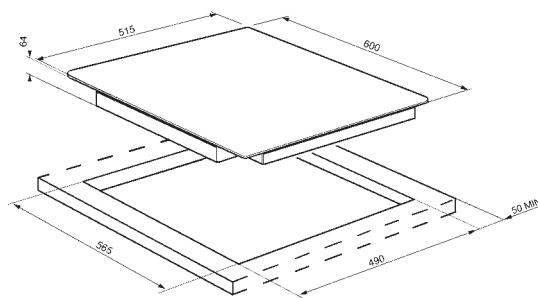

### SI321D

30CM MARC NEWSON™ TOUCH CONTROL INDUCTION HOB WITH GREY GRAPHICS



Individual timers for each zone  
 15 power levels  
 Automatic pan recognition  
 Automatic safety cut-out

2 zones including:  
 Rear: ø 210/100mm, 2.0kW – booster 3.1kW  
 Front: ø 160/100mm, 1.4kW – booster 2.0kW

NB: Only pans with a ferrous (magnetic) base are suitable for induction hobs

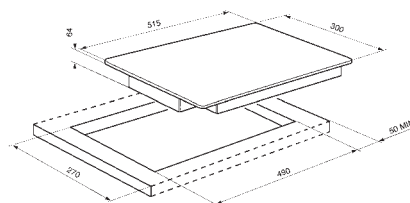



## CORTINA

The inspiration for the Cortina design came from master artisan wrought iron work traditionally produced in the Italian mountains. The style is characterised by interesting details which are reproduced in unusual combinations of colours and materials for a truly distinctive elegance.

# SF750RA

60cm 'CORTINA' MULTIFUNCTION OVEN, ANTIQUE COPPER WITH COPPER TRIM



11 functions, including Circulaire with upper & lower element



- Analogue clock, with automatic end cooking option
- Minute minder
- Triple glazed removable door
- Removable inner door
- Air cooling system
- Closed door grilling
- Easy clean enamel interior
- 2 halogen lamps
- Metal side supports, 5 cooking levels
- Vapor clean function

Maxi plus oven: GROSS capacity 79 litres  
 Maxi plus oven: NET capacity 72 litres

13 Amp power supply required



**SF750PO**  
 Cream with antique brass trim



**SF750PS**  
 Cream with antique silver trim



**SF750PX**  
 Cream with silver trim



**SF750AO**  
 Anthracite with antique brass trim



**SF750AS**  
 Anthracite with antique silver trim



**SF750OT**  
 Antique brass with brass trim



**SF750BS**  
 White with antique silver trim



**SF750RWX**  
 Red wine with silver trim

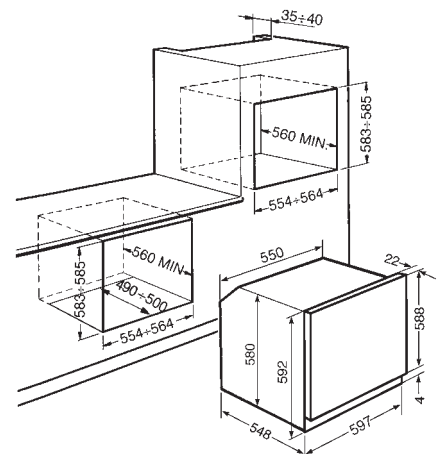

Technical drawing for ovens with codes beginning: SF750, SFP750 & SF700

## SF700PO

60CM 'CORTINA' MULTIFUNCTION OVEN, CREAM WITH ANTIQUE BRASS TRIM



6 cooking functions, including fan with upper & lower element



Analogue clock, with automatic end cooking option

Minute minder

Triple glazed removable door

Removable inner door

Air cooling system

Closed door grilling

Easy clean enamel interior

Interior light

Metal side supports, 5 cooking levels

Maxi plus oven: GROSS capacity 79 litres

Maxi plus oven: NET capacity 72 litres

13 Amp power supply required



**SF700BS**  
White with antique  
silver trim



**SF700AX**  
Anthracite with silver  
trim



## SR775PX

70cm 'CORTINA' GAS HOB CREAM, WITH SILVER & CREAM CONTROLS



5 burners:  
 Rear left: 2.50kW  
 Front left: 1.05kW  
 Centre: Ultra Rapid dual flame 3-way burner 5.00kW (3.90kW + 1.1kW)  
 Rear right: 1.65kW  
 Front right: 1.65kW

Cream base  
 Silver & cream controls  
 Heavy duty cast iron pan stands  
 Black burner caps

Electronic automatic ignition  
 Safety valves  
 Adaptable for LPG

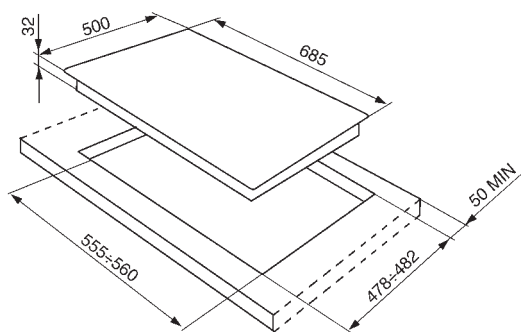

Technical drawing for all 70cm hobs



**SR775RA**  
All antique copper



**SR775XRW**  
St/steel with red wine controls



**SR775OT**  
All antique brass



**SR775AX**  
Anthracite with silver & anthracite controls



**SR775AO**  
Anthracite with antique brass & anthracite controls



**SR775PO**  
Cream with antique brass & cream controls



**SR775BS**  
White with antique silver controls

NB: All Cortina models are only available from selected dealers. For stockist details please see the website [www.smeguk.com](http://www.smeguk.com)



## SR764BS

60cm 'CORTINA' GAS HOB WHITE, WITH ANTIQUE SILVER CONTROLS



4 burners:  
 Left: 3.30kW  
 Rear central: 1.65kW  
 Front central: 1.05kW  
 Right: 2.20kW

White base  
 Antique silver controls  
 Heavy duty cast iron pan stands  
 Black burner caps

Electronic automatic ignition  
 Safety valves  
 Adaptable for LPG

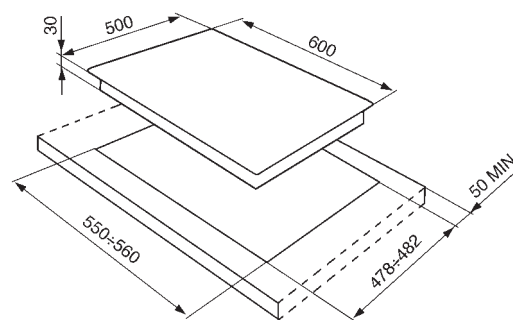

Technical drawing for all 60cm hobs



SR764RA  
 All antique copper



SR764XRW  
 St/steel with red wine controls



SR764OT  
 All antique brass



SR764AX  
 Anthracite with antique brass  
 & anthracite controls



SR764AO  
 Anthracite with antique brass &  
 anthracite controls



SR764PO  
 Cream with antique brass &  
 cream controls



SR764PX  
 Cream with silver and cream  
 controls



## Smeg coordinating collections

Domestic appliances are interpreted with different design families, each with an exclusive style. Every aesthetic design family offers a choice of different coordinating products. Linea, Classic and 50's Retro Style aesthetic lines are present in a wide range of appliances and can be coordinated throughout the kitchen to create a powerful style statement.

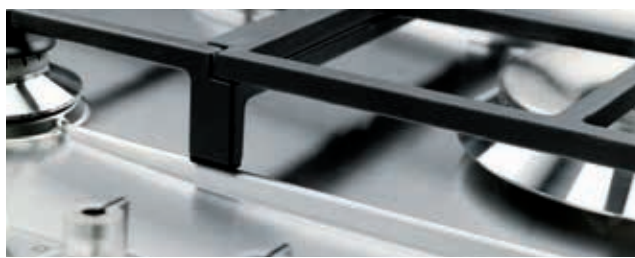

## LINEA

Distinctive products that incorporate modern minimalist design trends, the Linea aesthetic is characterised by symmetrical lines, balance and light. A series of ovens, coffee machine, hobs, hoods, fires and accessories are all extremely ergonomic and designed to maximise the available space, any combination will make a real style statement in the kitchen.



## CLASSIC

Strict forms, simple and essential design: a series of striking and elegant domestic appliances that are finished in smart stainless steel. Ovens, coffee machine, hobs, hoods, fires, fridges, dishwashers and more that make a real impact with their smooth and sleek design lines, the Smeg Classic range is timeless, yet with a contemporary feel.



## 50'S RETRO STYLE

Colour and retro lines for style icons: appliances that embody the glamour and rounded forms of the 1950's. Smeg 50's Retro Style products, a series of refrigerators and freezers, fires, dishwashers and washing machines, that have become recognised as cult objects.





OVENS, COFFEE MACHINES,  
MICROWAVES **32**

- Linea 38
- Classic 48
- Microwaves 46, 58, 60



HOBS **62**

- Gas 68
- Induction 86
- Ceramic 92



COOKERS & COOKING  
ACCESSORIES **96**

- Opera 104
- Victoria 110
- Symphony 114
- Concert 118
- Accessories 122



HOODS **124**



FIRES **144**



REFRIGERATION **154**



DISHWASHERS **184**



LAUNDRY **202**



SINKS & TAPS **210**

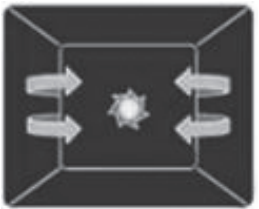

FURTHER INFORMATION

- Info charts 234
- Cooking functions Fold out section
- Key to symbols Fold out section

To simplify choice each product section has grouped items in a particular aesthetic design together, or indicated where similar articles will coordinate with an aesthetic design.

SMEG OVENS, THE PERFECT CHOICE FOR ANY KITCHEN.



State-of-the-art technology combined with a rigorous approach to aesthetics and top quality materials are the guiding principles behind the design of Smeg ovens, making the company name famous worldwide.

## DISTINCT DESIGNS, MADE-IN-ITALY

Designed and produced in Italy, a country with culinary specialities and engineering know-how recognised throughout the world, Smeg ovens have evolved through **serious research** and development, combined with the **specialised knowledge** of a nation that mixes the best quality ingredients to create excellent cooking appliances with **exclusive designs** that always offer **peak performance**.

Smeg give the opportunity to **personalise the kitchen** environment with a choice of products in **coordinated design lines**.



Architect styled **Piano Design** oven, with polished stainless steel both inside and out. See page 6 for range options.



**Marc Newson** designed ovens are characterised by distinctive use of colour and intuitive functions. See page 10 for range options.



The harmonious balance of features, materials and colours characterise the **Cortina** design. See page 18 for options.



**Linea** ovens; essential symmetry, one-touch illuminated controls and stylish use of glass result in simple modern design.



**Classic** ovens, a timeless style statement in the kitchen, with original handles and controls and the elegant use of stainless steel.

## TYPES OF OVENS

In various sizes, materials and colours and with different functions, the Smeg range includes **standard ovens** with a width of 60cm, and **compact models** with a reduced height of 45cm. Smeg also offer a **90cm extra wide oven** option or **double ovens**, perfect for batch cooking or for large families.



DOUBLE OVEN



EXTRA WIDE OVEN



STANDARD OVEN



COMPACT OVEN

## COOKING FLEXIBILITY

Smeg offer a variety of cooking **solutions perfect for different lifestyles**. The majority of ovens are **electric**, but the range also offers ovens with diverse cooking possibilities from more traditional cooking methods to solutions that allow you to **optimise cooking times** and prepare foods in the most **healthy and natural** way possible.

### Gas



Gas ovens have a number of advantages: instantaneous heat control, reduced cooking times and the ability to bake at much lower temperatures than it is possible to do in electric ovens.

Further details on page 55.

### Pizza



A pizza stone at the base of the oven above the lower element allows you to cook pizza evenly in just 3-5 minutes. Excellent too for cooking focaccia bread, savoury flans and fish or vegetables in foil, that won't dry up but stay moist.

### Microwave



Microwave energy shortens cooking times dramatically and produces notable energy savings.

### Steam



A steam oven cooks food in the most natural way, from vegetables to cakes and puddings, leaving all the foods' properties, flavour and aroma intact. Ideal for fat-free cooking, it is particularly recommended for reheating food without it becoming too dry or hard, since it introduces the right degree of moisture. What's more, steaming is ideal for many of today's dishes that need different cooking times, because their natural ingredients absorb only enough water as is necessary.

### Combination



As well as offering traditional, microwave or steam cooking, combination ovens allow you to combine two different systems. The combination increases your baking options and allows maximum versatility in the kitchen.

USER-FRIENDLY DISPLAYS



All the oven displays featured in our current range are clear and easy to use, most particularly the recently introduced LCD displays. Top of the range Linea SFP140 has a **touch control EasyGuide display** with interactive menus and automatic SmartSense cooking programmes and the **extra wide** model SFP3900X has a similar display activated by Classic controls. Other Linea and Classic models feature the latest **user friendly clear LCD display** which is extremely simple to operate.

EXCELLENCE AS STANDARD

Each Smeg oven includes a number of excellent features as standard. Continued research and testing, has allowed a number of clever innovations to be included throughout the range – features specifically designed to give the best ever results in the kitchen.



**MAXI CAVITIES:** Oven cavities are either **Maxi plus** at an impressive **72 litres net** (79l gross) or **Maxi** at a very generous **63 litres net** (70l gross).



**RAPID PRE-HEAT:** This option can be used to reach the selected temperature in the **fastest, most efficient** way.



**OPTIMAL ENERGY EFFICIENCY:** Some Maxi plus ovens can **reduce energy consumption by a further 20%** more than a model with a standard A Energy rating.



**5 COOKING LEVELS:** Maxi plus ovens have **five different cooking levels** (4 for Maxi ovens), and even the base of the oven can be used with the addition of a pizza stone to cook flans as well as pizzas.



**EFFECTIVE LIGHTING:** Lamps placed strategically on the sides of the oven **increase visibility** and light the oven cavity in the most effective way.



**ECOLOGIC:** This option can be set to restrict the power of the oven to just 2.3kW. Cooking times are slightly increased in this mode, but with **significant advantages for the environment** and a chance to make a **real energy saving**.

SAFETY AS A PRIORITY



**SAFE COOK:** Closed door grilling and cooking is an important feature in Smeg ovens, keeping cooking smells inside the oven and out of the kitchen, ensuring a safe cooking environment and reducing energy consumption.



This is made possible as Smeg incorporate its excellent **air cooling system** in all ovens and cookers. Many models include a switch which automatically turns off the power when the door is open, keeping heat loss to a minimum.



**TELESCOPIC SHELVES:** Simple telescopic rails **allow hot food to be checked very safely**, particularly when grilling, and are extremely convenient and easy to use.

Many models have these rails as standard, or they are available as an optional accessory, see page 122 for more details.

MULTI MENU

1 oven, 1 function, 1 temperature = 1 meal



Using the **Circulaire** cooking function and selecting a single temperature, a number of dishes can be cooked together at the same time with no flavour transfer, creating a complete meal very efficiently in the shortest possible time. There could even be space for an extra dish to be prepared for freezing later!

Smeg ovens, tested by professional chefs, combine excellent performance with user-friendliness. Continuous research and development ensures all the latest innovations are incorporated in the range guaranteeing great cooking results, low energy consumption and maximum respect for the environment.

## NEW TALL OR WIDE OPTIONS

New this season Smeg are introducing a double oven with a fresh layout, placing the main oven at the top, with the smaller auxiliary oven at the base. The Classic DOSP38X features electronic controls, a clear LCD display and **pyrolitic cleaning in the main oven**.

There is also a new **extra wide** 90cm MF oven, SFP3900X, with **pyrolitic cleaning**, and **EasyGuide display**, automatic **SmartSense menu options** and its own useful drawer - see page 50 for more details.



**PYROLITIC:** This automatic cleaning function works by heating the inside of the oven to 500° C at which temperature any grease and dirt is simply burned off. The Pyrolitic cycle is carried out in **total safety** because a special device locks the door for the duration of the process, and due to the quadruple glass of the oven door.



A simple 13 amp supply is all that is required to connect any Smeg 60cm wide single pyrolitic oven, giving the customer total flexibility and convenience.



All pyrolitic ovens feature a **Cooler door**, which indicates that during the pyrolitic cleaning cycle the outer door glass will become no hotter than 55°C.



## CLEANING MADE SIMPLE

### Easy clean enamel



The enamel finish of the oven cavity has a special antacid lining which helps to reduce the amount of dirt adhering to the surface.

### All glass inner door



The single flat surface is extremely easy to keep clean and it can be **removed completely** if necessary.

### Vapor Clean



Some models feature the Vapor Clean function which **makes cleaning easy**, by simply pouring a little water into the hollow at the oven base and setting the programme.

### Removable roof liner



This liner at the top of the oven can be easily removed for cleaning, it can even be put in the dishwasher.



## SMEG COMPACT OVENS, CUSTOMISED COOKING CHOICES

A variety of cooking solutions to enhance your creative flair.

45cm high compact ovens with either a Classic or Linea aesthetic and in a choice of colours, offer more options for equipping your kitchen. There are three types of compact ovens in the Smeg range:

Combination microwave oven, microwave oven with grill and combination steam oven.

Traditional 60cm ovens with Classic or Linea design aesthetics can be teamed with the compact ovens or coffee machines, in a column, or horizontally with plate warming drawers in co-ordinating styles and colours.



Smeg offer warming drawers in various heights and styles, which circulate warm air in order to heat up plates quickly and evenly. The base of the drawer is fitted with a non-slip mat to prevent plates and dishes sliding when the drawer is opened or closed.



## COMBINATION STEAM OVENS, A HEALTHY LIFESTYLE

The new combination steam ovens offer a variety of cooking solutions in one appliance for maximum user flexibility. It can be used either as a steam oven, or as a traditional oven, or alternatively the two methods can be combined together allowing the user to cook the tastiest dishes in the healthiest way possible.

The oven is also equipped with a grill to brown the food at the end of the cooking time and give it a delicious crispy finish. Steaming is also ideal for cooking different foods simultaneously that require different cooking times, because the natural ingredients absorb only enough water as is necessary.



Smeg offer design-coordinated compact products with different functions and features to create a super-efficient work area with its own personality and stylish looks. They can be combined with each other, including coffee machines, or teamed with standard ovens for maximum cooking versatility.

## SURFACEPLUS MICROWAVES

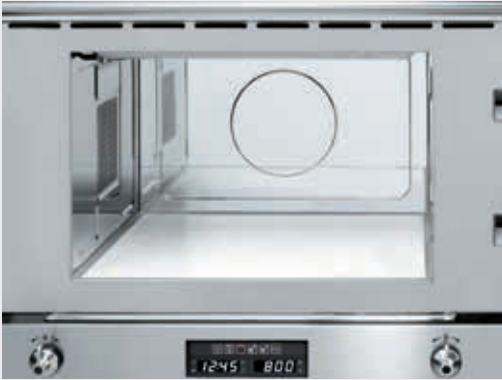

These microwaves in **Linea & Classic designs** have controls located at the bottom of the appliance allowing them to be installed overhead, a real space saver in small kitchens.



The traditional turntable has been replaced by **SurfacePlus** technology - a ceramic glass plate with a number of advantages. The whole cavity can be utilised so you are no longer limited to cooking items which only fit on the turntable, spills can be easily wiped away and the heat is constant as it comes from underneath meaning the food is heated more evenly and less energy is lost. Traditional microwaves are also available and can be found in the brochure on pages 60-61.

## AUTHENTIC COFFEE AT HOME

Smeg offers built-in coffee machines to complete your kitchen, a **bean to cup machine**, to make, professional espresso and cappuccino in the comfort of your own home. Available with Linea or Classic design they coordinate with other appliances in the same aesthetic line.

The built-in coffee machines utilise a 15 bar pressure pump. This maximises the flavour extraction from the coffee beans, optimising the pour, resulting in a delightful crema for a perfect cup of coffee every time.

The dispensing area is illuminated by 2 LED lights and offers a variable height grinder to suit different sized cups, and a user-friendly LCD display gives you immediate, clear information. Whats more the machine can be programmed to automatically switch on when you want, bringing it to the right temperature so that it's ready when you need it.



### Choice & versatility

Smeg coffee machines offer a wide range of features to meet every need and satisfy the most discerning palate. They are equipped to adjust to personal taste by providing the option of:



**3 adjustable coffee lengths** (Short/Espresso, Medium & Long), allowing total control when making a coffee and **5 levels of coffee strength** (Extra-light, Light, Medium, Strong & Extra strong)



It is also possible to use either ready **ground coffee**, or **beans** (with an adjustable grinding function) and prepare one or two cups at the same time. Milk or cappuccino can be prepared with the **steam function** to create a generous topping of foam, whilst there is a hot water function for making tea, chocolate, other drinks or to preheat coffee cups.

60CM "LINEA" PYROLITIC MULTIFUNCTION OVEN,  
ST/STEEL



12 functions Inc Circulaire with upper & lower element



- Interactive touch control Easy guide colour LCD display
- 50 automatic programmes
- 10 customisable recipes
- Special functions: warm, defrost, warm dishes, and rising SmartSense cooking
- Quadruple glazed removable doors
- Removable inner door glasses
- Electronic controls with child lock
- Air cooling system
- Closed door grilling
- Pyrolytic cleaning
- Easy clean enamel interior
- Rapid pre-heating
- Energy saving option – Ecologic
- Metal side supports, 5 cooking levels
- 2 halogen lights

Maxi plus oven GROSS capacity: 79 litres  
Maxi plus oven NET capacity: 72 litres

13 Amp power supply required



SFP140S  
Silver glass

### NEW EASYGUIDE TOUCH SCREEN



The SFP140 oven is equipped with an **EasyGuide touch screen with colour display**. The various oven functions and options, such as the **50 automatic programmes**, and **10 customisable recipes**, and numerous special functions can be easily accessed, set and personalised with the touch of a finger using the logical **SmartSense** system.

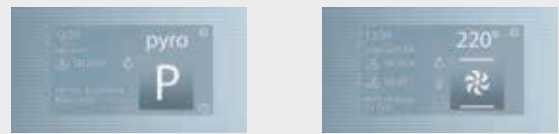

The **SmartSense** cooking system allows the user to choose the type of food, how it is cooked and its weight i.e. Meat - roast beef - medium - 1.5kg. The time, temperature and function are then automatically calculated - it will even tell you which shelf position to put the food on, guaranteeing great results even for less experienced chefs.

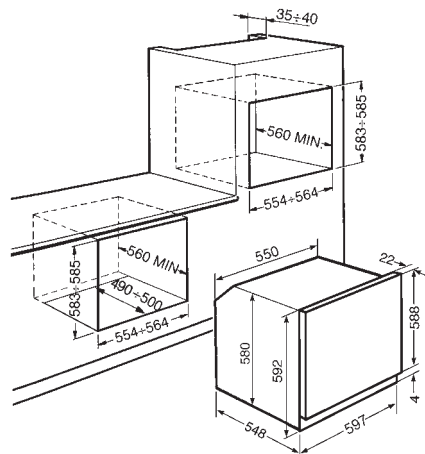



60CM "LINEA" PYROLYTIC MULTIFUNCTION OVEN,  
SILVER GLASS

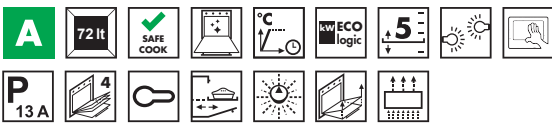

10 functions Inc Circulaire with upper & lower element



- LCD display & illuminated controls
- Quadruple glazed removable doors
- Removable inner door glasses
- Electronic controls with child lock
- Air cooling system
- Closed door grilling
- Rotisserie
- Pyrolytic cleaning**
- Easy clean enamel interior
- Rapid pre-heating**
- Energy saving option – Eco logic**
- Metal side supports, 5 cooking levels
- 2 halogen lights

Maxi plus oven GROSS capacity: 79 litres

Maxi plus oven NET capacity: 72 litres

13 Amp power supply required



SFP125  
St/steel



SFP125N  
Black

### EXTRA CLEAR DISPLAY



The smart LCD display featured on these **premium Linea ovens** is very simple to operate and all the information is clearly visible at a glance, due to its generous proportions.

Functions, temperatures and times are easily managed, with a quick movement of the controls to the right or left to choose a particular cooking function, or to set the required temperature, which is **adjusted in 5°C steps**, ensuring the correct cooking temperature can be selected for each recipe every time.

The same display can be found again on the more traditional design of the **premium Classic** oven models, which can be found on pages 48 and 52.

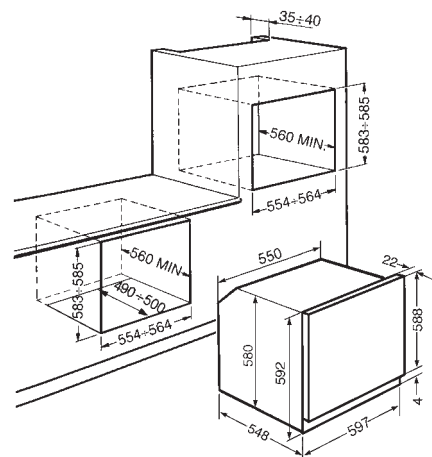

NB: From May 2014 these models will be replaced by SFP125S-1, SFP125-1 and SFP125N-1, same features as above but without rotisserie kit and with improved energy rating A-20%. See [www.smeguk.com](http://www.smeguk.com) for eventual details.

SFP109B

PYROLITIC

60CM "LINEA" PYROLITIC MULTIFUNCTION OVEN,  
WHITE

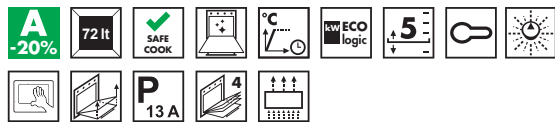

8 functions Inc Circulaire with upper & lower element



Digital electronic programmer with multi display & illuminated controls

- Quadruple glazed removable doors
- Removable inner door glasses
- Electronic controls with child lock
- Air cooling system
- Closed door grilling
- Pyrolytic cleaning**
- Easy clean enamel interior
- Rapid pre-heating**
- Energy saving option – Ecologic**
- Metal side supports, 5 cooking levels

Maxi plus oven GROSS capacity: 79 litres  
Maxi plus oven NET capacity: 72 litres

13 Amp power supply required



SFP109N  
Black



SFP109S  
Silver glass

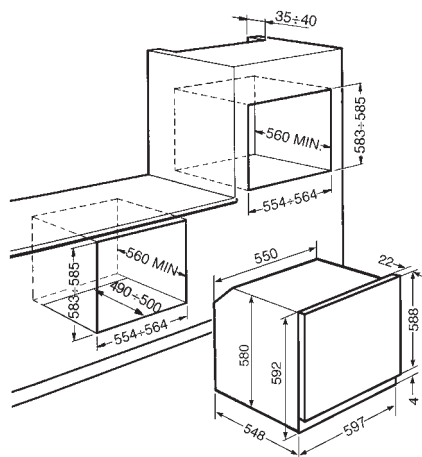

SF109S  
St/steel

SF109N

60CM "LINEA" MULTIFUNCTION OVEN,  
BLACK

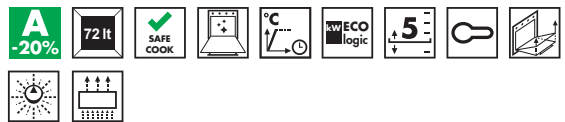

8 functions Inc Circulaire with upper & lower element



Digital electronic programmer with multi display & illuminated controls

- Double glazed removable doors
- Removable inner door glass
- Electronic controls with child lock
- Air cooling system
- Closed door grilling
- Energy saving option - Ecologic**
- Easy clean enamel interior
- Rapid pre-heating**
- Metal side supports, 5 cooking levels
- Vapor clean function**

Maxi plus oven GROSS capacity: 79 litres  
Maxi plus oven NET capacity: 72 litres

13 Amp power supply required

## SC45MCB2

45cm H

60cm "LINEA" COMPACT COMBINATION MICROWAVE OVEN,  
WHITE



45cm reduced height compact oven

10 functions



Digital electronic programmer with multi display  
Electronic timer with end of cooking alarm  
Double glazed removable door  
Air cooling system  
**Energy saving option - Ecologic**  
Closed door grilling  
Tilting grill  
Microwave pizza cooking function  
Full fan cooking (can also be combined with microwave)  
Electronic thermostatic controls  
Defrost by weight or time  
Child safety lock

Oven capacity: gross - 37 litres, net - 34 litres

30 Amp power supply required



SC45MCSG2  
Silver glass



SC45MCNE2  
Black



SC45MC2  
St/steel

## SC45MNE2

45cm H

60cm "LINEA" COMPACT MICROWAVE OVEN WITH GRILL,  
BLACK



45cm reduced height compact oven

6 functions



Digital electronic programmer with multi display  
Electronic timer with end of cooking alarm  
Double glazed door  
Air cooling system  
**Energy saving option - Ecologic**  
Closed door grilling  
Tilting grill  
Microwave pizza cooking function  
Electronic thermostatic controls  
Defrost by weight or time  
Child safety lock

Oven capacity: gross - 37 litres, net - 34 litres

30 Amp power supply required



SC45MB2  
White



SC45M2  
St/steel

# SC45VC2

45cm H

60cm "LINEA" COMPACT COMBINATION STEAM OVEN,  
St/STEEL



45cm reduced height compact oven

10 functions:



- Digital electronic programmer with multi display
- Electronic timer with end of cooking alarm
- Triple glazed removable door
- Air cooling system
- Energy saving option – Ecologic**
- Closed door grilling
- Pizza cooking function
- Water reservoir (1.2 litres)
- Electronic thermostatic controls
- 3 cooking levels
- Metal side supports
- De-scaling function
- Child safety lock

Oven capacity: gross - 37 litres, net - 31 litres

30 Amp power supply required

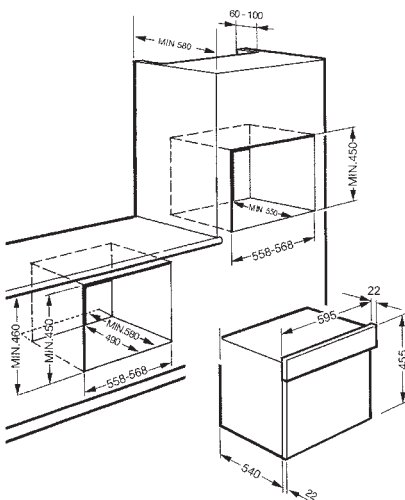
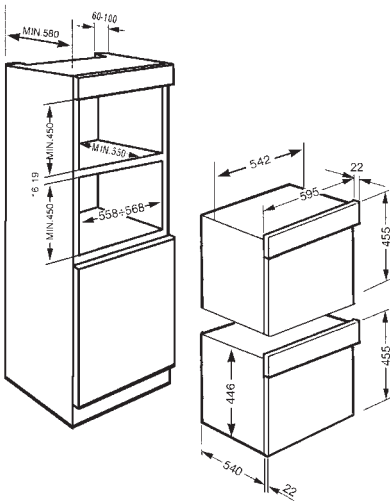

# CMSC45NE

45cm H

60CM "LINEA" FULLY AUTOMATIC COFFEE MACHINE, BEANS OR GROUND COFFEE, BLACK



45cm reduced height coffee machine

Coffee function: regular or double coffee (1 or 2 cups at same time)  
Steam function: for cappuccino  
Hot water function: for tea or other hot drinks

Multi-language LCD display  
5 level programmable coffee strength  
Programmable water quantity per cup  
Programmable automatic switch on  
Automatic rinsing (at every switch on/switch off)  
Adjustable coffee temperature  
Fan cooling system

Frothing nozzle for cappuccino  
Adjustable coffee dispenser (for tall or short cup)  
Drip tray  
2 Lights

Capacity of water tank: 1.80 litres  
Capacity of coffee beans container: 220 g  
Pump pressure: 1.5 bar

Nominal power: 1.35 kW  
**13 Amp power supply required**

OPTIONAL EXTRAS:  
St/steel divider strip **PR3845X**



CMSC45B  
White

CMSC45  
St/steel

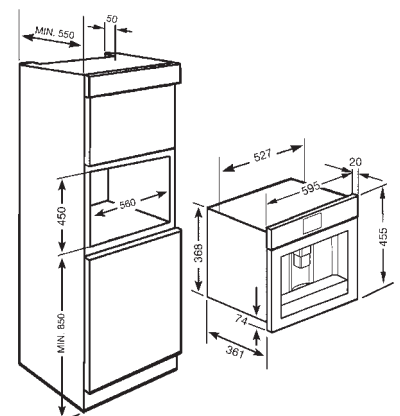



SFP109B  
CMSC45B  
CT15B-2

## MP122

"LINEA" MICROWAVE OVEN WITH ELECTRIC GRILL, SILVER GLASS  
320MM DEPTH ALLOWS INSTALLATION IN WALL UNIT



6 functions including pizza

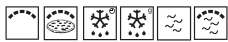

Side opening door

Controls positioned at the bottom

Electronic timer

Tilting grill

Quartz grill: 1.2 kW

Microwave output power: 850 W

22 litre capacity

Surfaceplus ceramic base

St/steel interior

Cooling system

Automatic calculation of defrosting by time or weight

Quick start option

Child safety lock

STANDARD ACCESSORIES:

Chrome grill support

OPTIONAL EXTRAS:

KITMP38 – thinner bar to reduce height to 38cm

KITPLATE – crisper

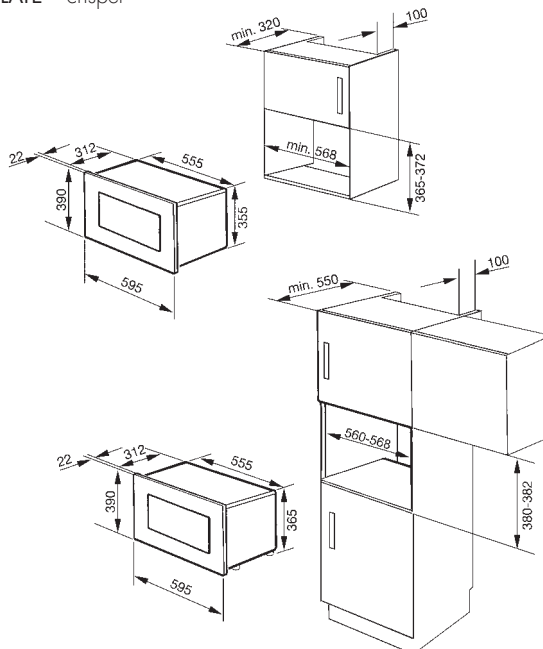

## FME120

"LINEA" MICROWAVE OVEN WITH ELECTRIC GRILL, SILVER GLASS



5 Microwave power levels

Electronic timer

Digital clock

90 minute timer

Quartz grill: 1kW

Microwave output power: 850W

20 litre capacity

St/steel interior

Cooling system

Auto calculation of defrosting by time or weight

Programmable memory functions

STANDARD ACCESSORIES:

Kit for build in installation

2 level chrome grill support

Glass turntable

Coordinates with "Linea" aesthetic



FME120N  
Black

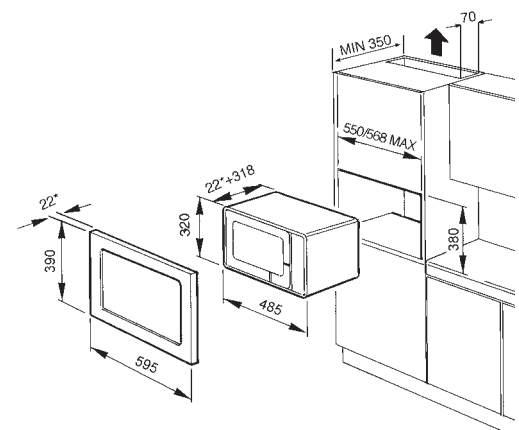

## CT29-2

## LARGE CAPACITY

29CM HEIGHT "LINEA" BUILT-IN WARMING DRAWER, ST/STEEL



Suitable for fitting directly beneath standard, compact and microwave ovens or coffee machines in a column

Maximum load weight above drawer: 45kg  
 Maximum load weight inside drawer: 25kg  
 Temperature range 30 to 75° C  
 Electronic touch controls  
 Fitted with "Quadro" gliders for smooth operation  
 Adjustable timer 0 to 240 minutes with automatic switch off  
 Delay timer 0 to 9h 50m  
 Power heating element 500W  
 Non slip drawer liner  
 2 levels - shelf included

## CT15-2

15CM HEIGHT "LINEA" BUILT-IN WARMING DRAWER, ST/STEEL



Suitable for fitting directly beneath a 45cm height compact oven

Both items together fit in a standard 60cm aperture  
 Maximum load weight 25kg  
 Adjustable timer from 0 to 240 minutes with automatic switch off  
 Temperature range from 30 to 75°C  
 Smooth drawer movement 'quadro gliders'  
 Non slip drawer liner  
 Electronic touch controls  
 Delay timer 0 to 9h 50m  
 Power heating element: 400W

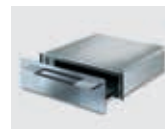

CT15SG2  
Silver glass



CT15NE-2  
Black

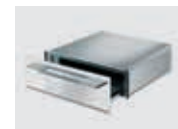

CT15B-2  
White

ALSO AVAILABLE:



### PR3845X

60cm wide stainless steel divider for use between two or more appliances when installed in column in a 60cm cavity.

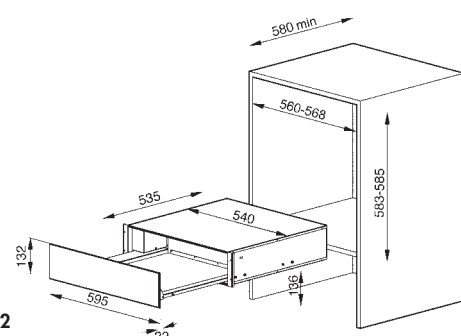
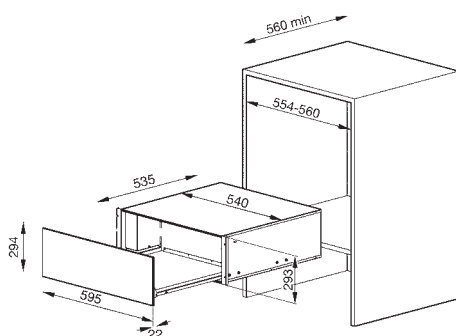

CT15-2  
 CT15NE-2  
 CT15SG2  
 CT15B-2

# DOSP38X

# PYROLITIC

60CM "CLASSIC" MULTIFUNCTION DOUBLE OVEN WITH PYROLITIC CLEANING IN THE MAIN OVEN, ST/STEEL



### UPPER MAIN OVEN



10 functions inc Circulaire with upper & lower element



LCD electronic display/programmer  
 Quadruple glazed removable doors  
 Removable inner door glasses  
**Electronic controls with child lock**  
 Air cooling system  
 Closed door grilling  
**Pyrolytic cleaning**  
**Energy saving option – Ecologic**  
 Metal side supports, 5 cooking levels  
 Maxi plus oven GROSS capacity: 79 litres  
 Maxi plus oven NET capacity: 72 litres

### LOWER AUXILIARY OVEN

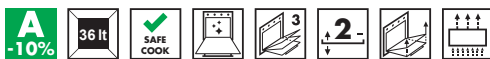

4 functions Inc Upper & lower element



Air cooling system  
 Closed door grilling  
 Triple glazed removable door  
 Removable door glass  
 Oven GROSS capacity: 41 litres  
 Oven NET capacity: 36 litres

30 Amp power supply required

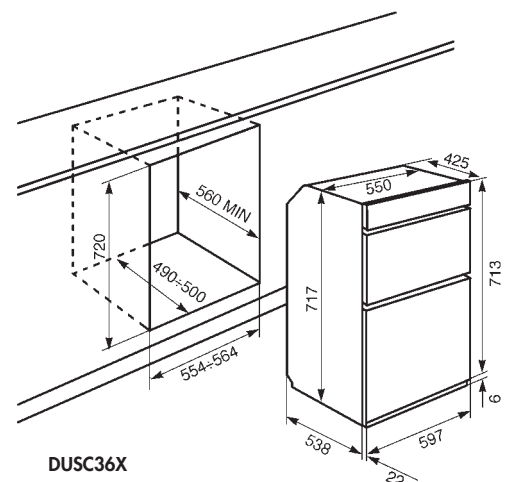
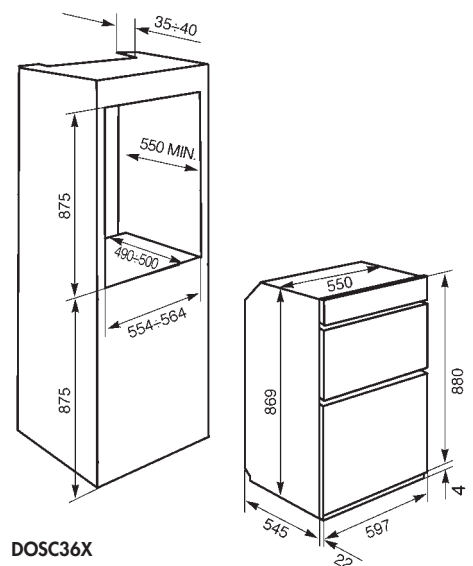
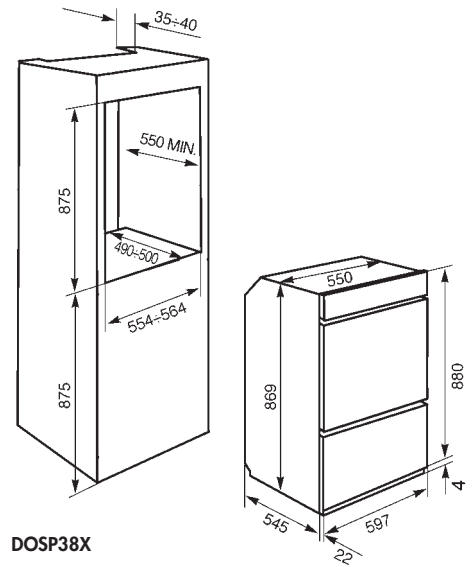

NB: Due to the restricted space remaining beneath the work surface above these oven units, care must be taken when selecting a hob to ensure it will fit.

## DOSC36X

60cm "CLASSIC" MULTIFUNCTION DOUBLE OVEN,  
ST/STEEL



### LOWER MAIN OVEN



6 functions Inc Circulaire element with fan



Analogue LED electronic clock/programmer  
Air cooling system  
Closed door grilling  
Triple glazed removable door  
Removable inner door glass  
Easy clean enamel interior  
Metal side supports, 5 cooking levels  
Maxi plus oven GROSS capacity: 79 litres  
Maxi plus oven NET capacity: 72 litres

### UPPER AUXILIARY OVEN



4 functions Inc Upper & lower element



Air cooling system  
Closed door grilling  
Triple glazed removable door  
Removable inner door glass  
Variable grill  
Easy clean enamel interior  
Metal side supports, 2 cooking levels  
Oven GROSS capacity: 41 litres  
Oven NET capacity: 36 litres

30 Amp power supply required

## DUSC36X

60cm "CLASSIC" MULTIFUNCTION DOUBLE UNDER COUNTER  
OVEN, ST/STEEL



### LOWER MAIN OVEN



6 functions Inc Circulaire element with fan



Analogue LED electronic clock/programmer  
Air cooling system  
Closed door grilling  
Triple glazed removable cooler door  
All glass inner door  
Metal side supports, 4 cooking levels  
Maxi oven GROSS capacity: 70 litres  
Maxi oven NET capacity: 63 litres

### UPPER AUXILIARY OVEN



4 functions Inc Upper & lower element



Air cooling system  
Closed door grilling  
Triple glazed removable cooler door  
Removable inner door glasses  
Variable grill  
Easy clean enamel interior  
Metal side supports, 2 cooking levels  
Oven GROSS capacity: 41 litres  
Oven NET capacity: 36 litres

30 Amp power supply required

90CM "CLASSIC" PYROLITIC MULTIFUNCTION OVEN WITH INTEGRATED UTILITY DRAWER, ST/STEEL



12 functions inc Circulaire with upper & lower element



Interactive menu & automatic programmes

Easy guide display

SmartSense cooking system

50 automatic programmes

10 customisable recipes

Special functions: warm, defrost, warm dishes, rising and minute minder

Quadruple glazed removable doors

Removable inner door glasses

Electronic controls with child lock

Air cooling system

Closed door grilling

Pyrolitic cleaning

Easy clean enamel interior

Energy saving option – Ecologic

Metal side supports, 4 cooking levels

2 halogen lights

Integrated utility drawer beneath the oven

Oven GROSS capacity: 90 litres

Oven NET capacity: 80 litres

30 Amp power supply required

NB: Reduced height models SF3910XR and SF9315XR will be available during the first half of 2014. See [www.smeguk.com](http://www.smeguk.com) for eventual details.

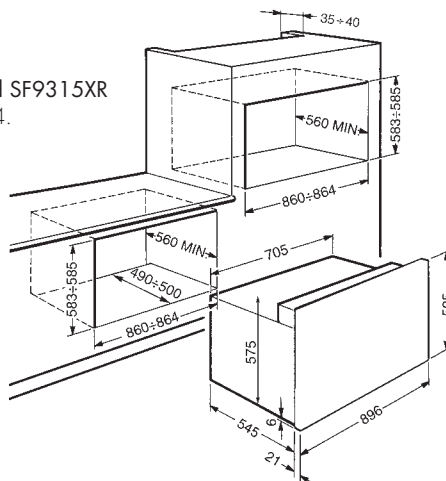

EASYGUIDE DISPLAY



The SFP3900X oven is very simple to operate with its **Interactive EasyGuide** display. The **SmartSense** cooking system can automatically calculate the time, temperature and cook function when the type of food and its weight are entered, or one of the 50 automatic programmes can be selected. There are 10 spaces for personal favourite recipes to be stored.



This **extra wide 80 litre capacity** oven is extremely versatile, with space for many different sized dishes to be used at once, and they can be managed simply and safely, using the **telescopic shelf guides** supplied. The oven can be maintained in its original pristine condition by running the **pyrolitic cleaning programme** regularly.

This oven model includes an **integrated drawer beneath the oven**, perfect for storing extra pans and oven shelves when not required inside the oven for cooking.



SFP3900X

# SFP390X

# PYROLITIC

60cm "CLASSIC" PYROLITIC MULTIFUNCTION OVEN,  
FINGER FRIENDLY ST/STEEL



11 functions inc Circulaire with upper & lower element



- LCD electronic clock/programmer
- Quadruple glazed removable cooler door
- Removable inner door glasses
- Electronic controls with child lock**
- Automatic switch-off when door is open
- Air cooling system
- Closed door grilling
- Pyrolytic cleaning**
- Rotisserie
- Easy clean enamel interior
- Rapid pre-heating**
- Energy saving option - Ecologic**
- 2 halogen lamps
- Metal side supports, 5 cooking levels

Maxi plus oven GROSS capacity: 79 litres  
Maxi plus oven NET capacity: 72 litres

**13 Amp power supply required**

# SF390X

60cm "CLASSIC" MULTIFUNCTION OVEN,  
FINGER FRIENDLY ST/STEEL



11 functions inc Circulaire with upper & lower element



- LCD electronic clock/programmer
- Triple glazed removable door
- Removable inner door glasses
- Electronic controls with child lock**
- Automatic switch-off when door is open
- Air cooling system
- Closed door grilling
- Easy clean enamel interior
- Rapid pre-heating**
- Energy saving option - Ecologic**
- 2 halogen lamps
- Metal side supports, 5 cooking levels
- Vapor clean function**

Maxi plus oven GROSS capacity: 79 litres  
Maxi plus oven NET capacity: 72 litres

**13 Amp power supply required**

NB: From May 2014 this model will be replaced by SFP390X-1, same features as above but without rotisserie kit and with improved energy rating A-20%. See [www.smeguk.com](http://www.smeguk.com) for eventual details.

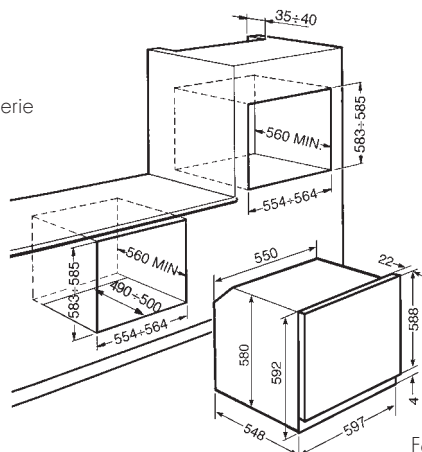

For additional information see pages 234-244



SFP378X

PYROLITIC

60CM "CLASSIC" PYROLITIC MULTIFUNCTION OVEN,  
FINGER FRIENDLY ST/STEEL

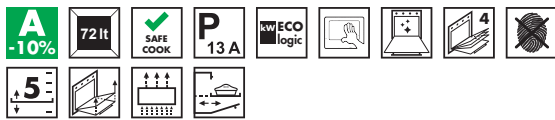

8 functions Inc Circulaire with upper & lower element



- Electronic clock/timer
- Quadruple glazed removable door
- Removable inner door glasses
- Air cooling system
- Closed door grilling
- Pyrolitic cleaning**
- Easy clean enamel interior
- Energy saving option - Ecologic**
- Metal side supports, 5 cooking levels

Maxi plus oven GROSS capacity: 79 litres  
Maxi plus oven NET capacity: 72 litres

13 Amp power supply required

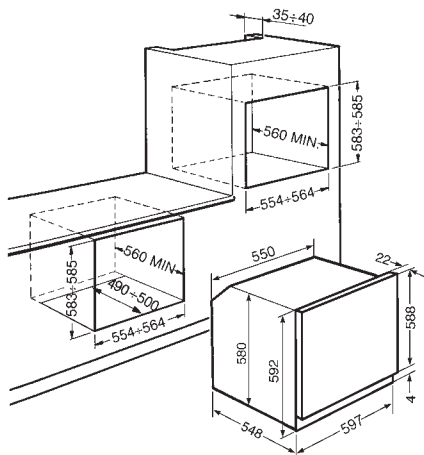

SF372X

60CM "CLASSIC" MULTIFUNCTION OVEN,  
FINGER FRIENDLY ST/STEEL



9 functions Inc Circulaire with upper & lower element



- Electronic clock/timer
- Double glazed removable door
- Removable inner door glasses
- Air cooling system
- Closed door grilling
- Easy clean enamel interior
- Metal side supports, 5 cooking levels
- Vapor clean function**

Maxi plus oven GROSS capacity: 79 litres  
Maxi plus oven NET capacity: 72 litres

13 Amp power supply required

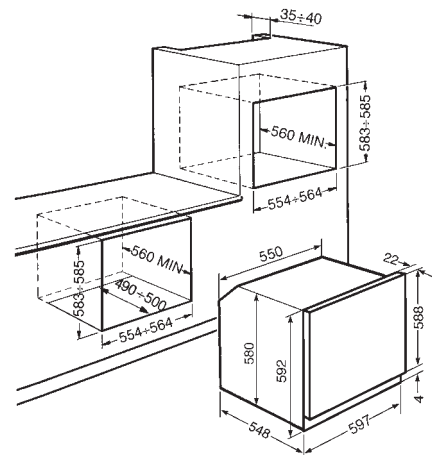

60CM "CLASSIC" GAS FAN OVEN WITH ELECTRIC GRILL,  
FINGER FRIENDLY ST/STEEL

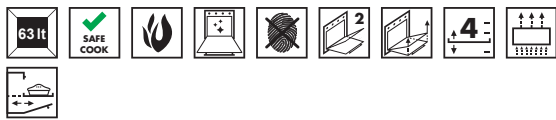

8 functions Inc Circogas (fan with bottom element)



Removable inner door glass

Air cooling system

Closed door grilling

Rotisserie

Easy clean enamel interior

Metal side supports, 4 cooking levels

Minute minder

Gas temperatures: Min 150°C Max 295°C

Automatic electronic ignition

Safety valve

Adjustable for LPG

Maxi oven GROSS capacity: 70 litres

Maxi oven NET capacity: 63 litres

13 Amp power supply required

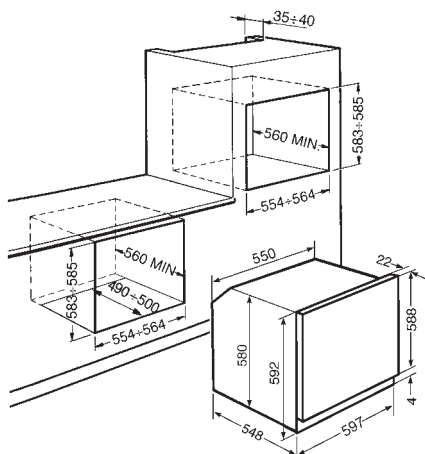

## TRADITIONAL GAS COOKING



Gas ovens allow the customer to cook in a traditional way with natural and constant oven temperature. The Smeg SF341GVX has a continental gas burner which is positioned centrally from front to back in the base of the oven.



The SF341GVX has an innovative CIRCOGAS function - a GAS+FAN cooking mode which makes gas cooking more versatile as it ensures a much more constant and uniform heat, and also reduces the pre-heat time, all of which contribute to excellent and efficient cooking performance.

The SF341GVX also has an integral electric grill which can be used to brown dishes already cooked through by gas, or as a stand-alone grill, which can be combined with the fan to cook thick chops/steak or similar. Alternatively it can be combined with the rotisserie, with or without the fan.

A triple safety system is in place to ensure peace of mind: the gas supply is automatically cut off in the event of the flame being accidentally extinguished; the oven can only be ignited with the door open; and the electric grill can only function when the gas is off.



## S45MCX2

45cm H

60cm "CLASSIC" COMPACT COMBINATION MICROWAVE OVEN,  
ST/STEEL



45cm reduced height compact oven

10 functions



- Digital electronic programmer with multi display
- Electronic timer with end of cooking alarm
- Double glazed removable door
- Air cooling system
- Energy saving option - Ecologic**
- Closed door grilling
- Tilting grill
- Full fan cooking (can also be combined with microwave)
- Defrost by weight or time
- Microwave pizza cooking function
- Electronic thermostatic controls
- Child safety lock

Oven capacity: gross - 37 litres, net - 34 litres

30 Amp power supply required

## S45MX2

45cm H

60cm "CLASSIC" COMPACT MICROWAVE OVEN WITH GRILL,  
ST/STEEL



45cm reduced height compact oven

6 functions



- Digital electronic programmer with multi display
- Electronic timer with end of cooking alarm
- Double glazed door
- Air cooling system
- Energy saving option - Ecologic**
- Closed door grilling
- Tilting grill
- Microwave pizza cooking function
- Defrost by weight or time
- Child safety lock

Oven capacity: gross - 37 litres, net - 34 litres

30 Amp power supply required

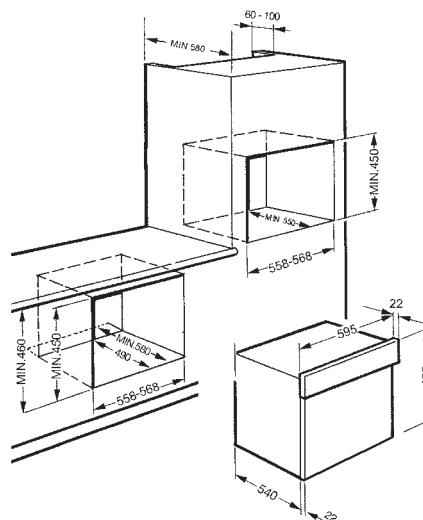

## S45VCX2

45cm H

60CM "CLASSIC" COMPACT COMBINATION STEAM OVEN,  
ST/STEEL



45cm reduced height compact oven

10 functions:



Digital electronic programmer with multi display

Electronic timer with end of cooking alarm

Triple glazed removable door

Air cooling system

**Energy saving option – Ecologic**

Closed door grilling

Pizza cooking function

Water reservoir (1.2 litres)

Electronic thermostatic controls

3 cooking levels

Metal side supports

De-scaling function

Child safety lock

Oven capacity: gross - 37 litres, net - 31 litres

30 Amp power supply required

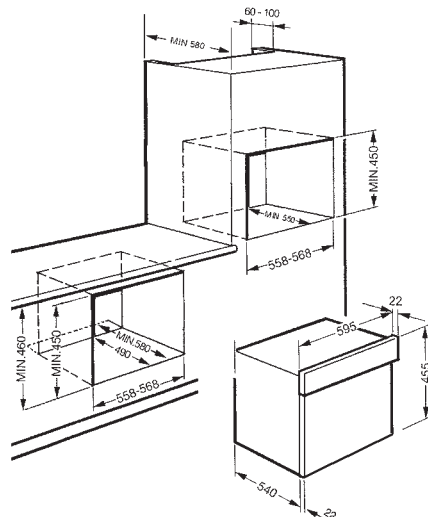

## CMS45X

45cm H

60CM "CLASSIC" FULLY AUTOMATIC COFFEE MACHINE, BEANS OR  
GROUND COFFEE, ST/STEEL



45cm reduced height coffee machine

Coffee function: regular or double coffee

(1 or 2 cups at same time)

Steam function: for cappuccino

Hot water function: for tea or other hot drinks

Multi-language LCD display

5 level programmable coffee strength

Programmable water quantity per cup

Programmable automatic switch on

Automatic Rinsing (at every switch on/switch off)

Adjustable coffee temperature

Fan cooling system

Frothing nozzle for cappuccino

Adjustable coffee dispenser (for tall or short cup)

Drip tray

2 Lights

Capacity of water tank: 1.80 litres

Capacity of Coffee beans container: 220 g

Pump pressure: 15 bar

Nominal power: 1.35 kW

**13 Amp power supply required**

OPTIONAL EXTRAS:

St/steel divider strip **PR3845X**

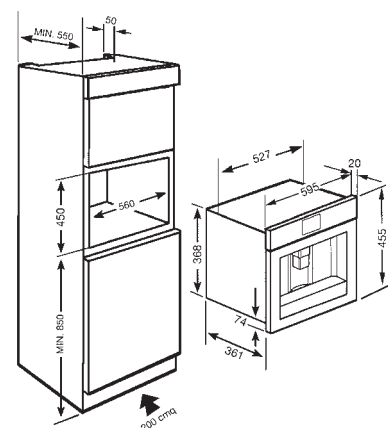

For additional information see pages 234-244

## MP322X

"CLASSIC" MICROWAVE OVEN WITH ELECTRIC GRILL, ST/STEEL  
320MM DEPTH ALLOWS INSTALLATION IN WALL UNIT



6 functions including pizza



Side opening door

Controls positioned at the bottom

Electronic timer

Tilting grill

Quartz grill: 1.2 kW

Microwave output power: 850 W

22 litre capacity

Surfaceplus ceramic base

St/steel interior

Cooling system

Automatic calculation of defrosting by time or weight

Child safety lock

STANDARD ACCESSORIES:

Chrome grill support

OPTIONAL EXTRAS:

KITMP38 – thinner bar to reduce height to 38cm

KITPLATE – crisper

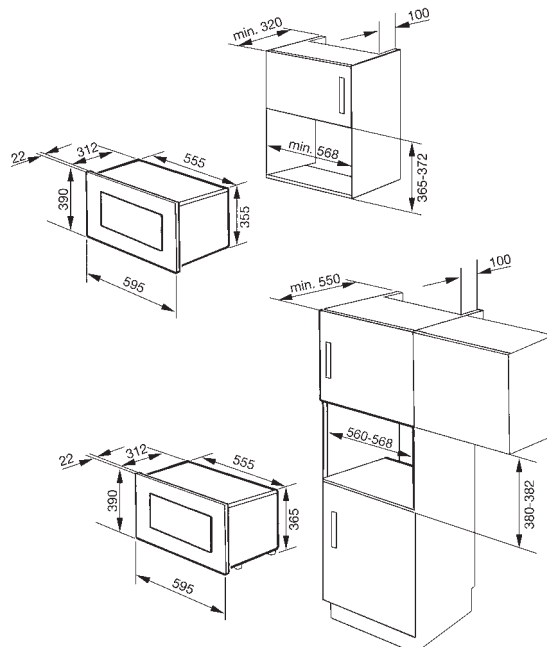

## CT29X

## LARGE CAPACITY

29CM HEIGHT "CLASSIC" BUILT-IN WARMING DRAWER,  
ST/STEEL



Suitable for fitting directly beneath standard, compact and microwave ovens or coffee machines in a column

Maximum load weight above drawer: 45kg

Maximum load weight inside drawer: 25kg

Temperature range 30 to 75° C

Electronic touch controls

Fitted with "Quadro" gliders for smooth operation

Adjustable timer 0 to 240 minutes with automatic switch off

Delay timer 0 to 9h 50m

Power heating element 500W

Non slip drawer liner

2 levels - shelf included

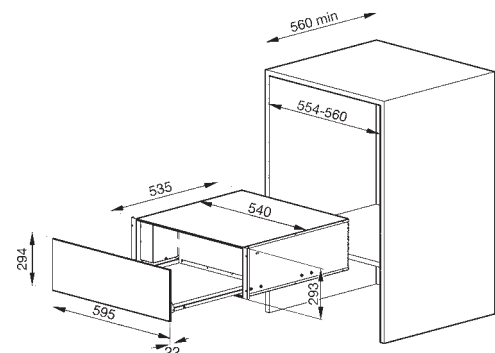

## CTSC21X

20.5CM HEIGHT "CLASSIC" BUILT IN WARMING DRAWER,  
ST/STEEL



Suitable for fitting directly beneath the microwave ovens,  
FME24X-2 and FME20TC3. Both items together fit standard  
60cm aperture  
Maximum load weight: 20 kg  
Minute minder with automatic switch off, can be set from 10 to  
90 minutes  
Drawer has 400W heater, and is fitted with a tangential  
cooling fan  
Temperature range 30-70C  
LED showing warming in progress is visible with the door closed  
Fitted with 'Quadro' gliders for smooth operation

ALSO AVAILABLE:



### PR3845X

60cm wide stainless steel divider for use  
between two or more appliances when  
installed in column in a 60cm cavity.

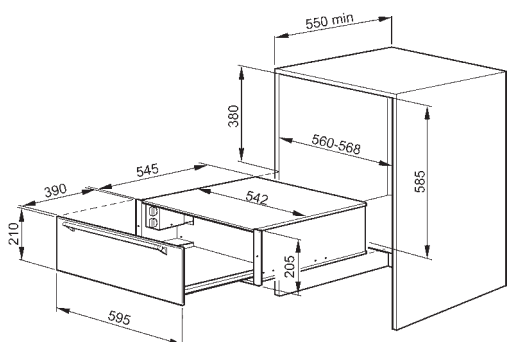

## CT15X

15CM HEIGHT "CLASSIC" BUILT IN WARMING DRAWER,  
ST/STEEL



Suitable for fitting directly beneath a 45cm height compact  
oven  
Both items together fit in a standard 60cm aperture  
Maximum load weight 25kg  
Adjustable timer from 0 to 240 minutes with automatic switch  
off  
Temperature range from 30 to 75°C  
Smooth drawer movement 'quadro gliders'  
Non slip drawer liner  
Electronic touch controls  
Delay timer 0 to 9h 50m  
Power heating element: 400W

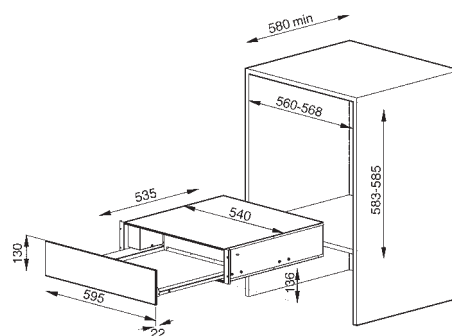

For additional information see pages 234-244

## MP122

"LINEA" MICROWAVE OVEN WITH ELECTRIC GRILL, SILVER GLASS  
320MM DEPTH ALLOWS INSTALLATION IN WALL UNIT



6 functions including pizza

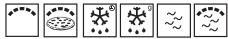

Side opening door

Controls positioned at the bottom

Electronic timer

Tilting grill

Quartz grill: 1.2 kW

Microwave output power: 850 W

22 litre capacity

Surfaceplus ceramic base

St/steel interior

Cooling system

Automatic calculation of defrosting by time or weight

Quick start option

Child safety lock

STANDARD ACCESSORIES:

Chrome grill support

OPTIONAL EXTRAS:

KITMP38 – thinner bar to reduce height to 38cm

KITPLATE – crisper



**MP322X**  
Classic style,  
Stainless steel

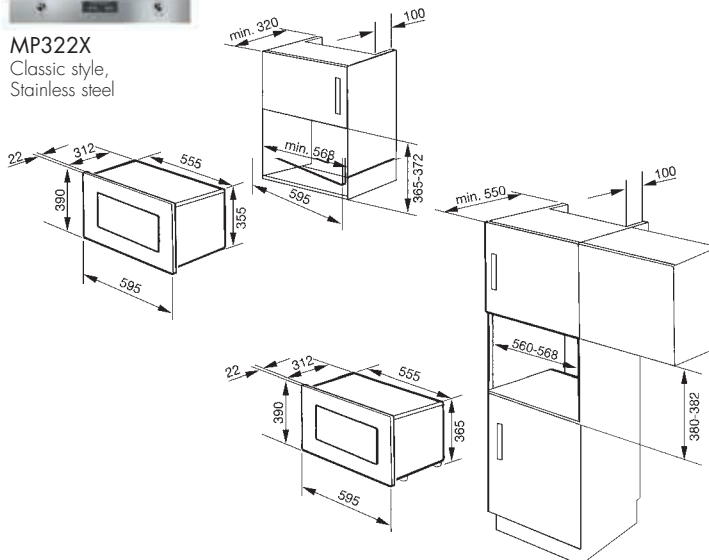

## FME120N

"LINEA" MICROWAVE OVEN WITH ELECTRIC GRILL, BLACK



5 Microwave power levels

Electronic timer

Digital clock

90 minute timer

Quartz grill: 1 kW

Microwave output power: 850W

20 litre capacity

St/steel interior

Cooling system

Auto calculation of defrosting by time or weight

Programmable memory functions

STANDARD ACCESSORIES:

Kit for build in installation

2 level chrome grill support

Glass turntable

Coordinates with "Linea" aesthetic



**FME120**  
Silver glass  
Coordinates with  
"Linea" aesthetic

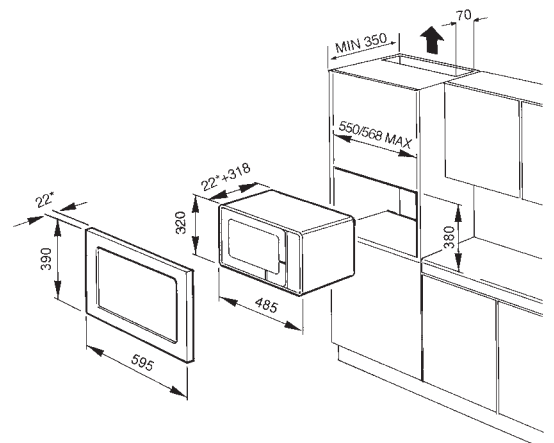

## FME24X-2

MICROWAVE OVEN WITH ELECTRIC GRILL,  
FINGER FRIENDLY ST/STEEL



- 5 Microwave power levels
- Electronic timer
- Digital clock
- 60 minute timer
- Quartz grill: 1.2kW
- Microwave output power: 900W
- 24 litre capacity
- St/steel interior

STANDARD ACCESSORIES:  
Build in frame part of product design  
Chrome grill support  
Non-stick pizza dish  
Glass turntable

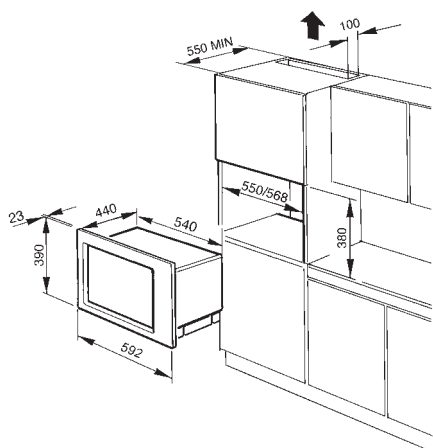

## FME20TC3

TOUCH CONTROL MIRCOWAVE WITH ELECTRIC GRILL, FINGER  
FRIENDLY ST/STEEL



- 5 Microwave power levels
- Electronic timer
- Digital clock
- 90 minute timer
- Quartz grill: 1kW
- Microwave output power: 850W
- 20 litre capacity
- St/steel interior
- Cooling system
- Auto calculation of defrosting by time or weight
- Programmable memory functions

STANDARD ACCESSORIES:  
Kit for build in installation  
2 level chrome grill support  
Glass turntable

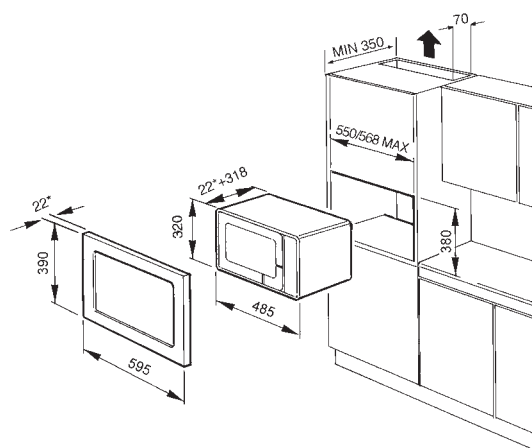

## SMEG HOBS: FOR SERIOUS COOKS

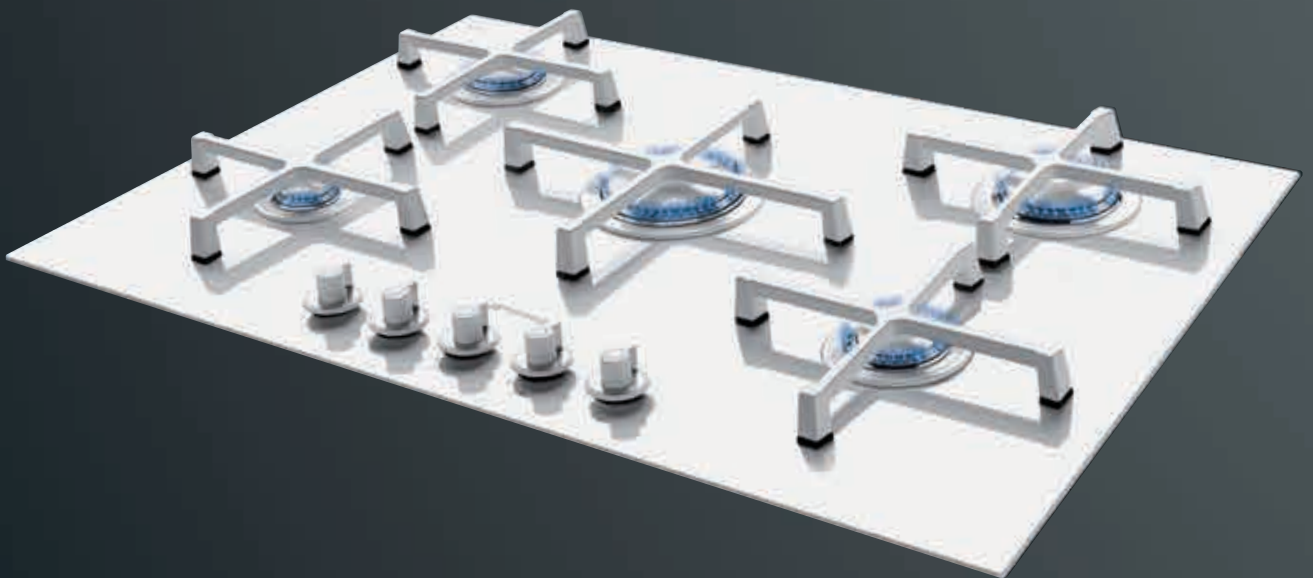

Smeg hobs are distinguished by their high quality materials, and design of pan-stands and burners. These exclusive aesthetics offer a hob for every requirement. 18/10 Stainless steel, elegant and bright, plays a central role in the kitchen, whilst sophisticated surfaces in glass, or matt glass provide a surprising use of colour.

## MAXIMUM CHOICE

---

The ideal solution for every style of kitchen, Smeg offer a comprehensive range of gas, induction and ceramic hobs that match the ovens perfectly, with a **wide choice of colours, sizes, shapes and types.**



GAS



INDUCTION

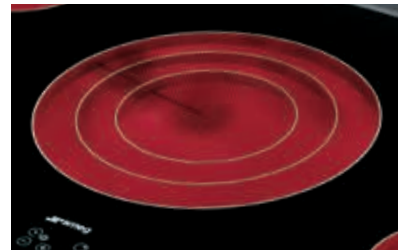

CERAMIC

The range of sizes on offer include:

- small domino hobs (30cm wide)
- traditional 60, 70, 72, 74, 77, 86, 90
- 100 cm wide slimline hob

The different depths and widths available allow a variety of hob combinations to suit any kitchen layout, using as little or as much work space as necessary.

Smeg induction and ceramic hobs each have two types of finish to choose from depending on the type of aesthetic the customer requires. Induction hobs are finished with either **straight edges** for a modern look which can be flush-fitted into the work surface if desired, or alternatively with a more traditional **angled edge** finish which is easily blended into any kitchen aesthetic. Ceramic hobs are also finished with angled edges, or, for a more sleek finish the range includes ceramic hobs with an ultra slim 2mm tall **wafer-thin frame**.

The choice has been further extended by the addition of Marc Newson designer induction hobs with stylish and user friendly serigraphy.

## DESIGN FOR FUNCTIONALITY

---

Smeg offer **various configurations** of burners and electric cooking zones: from **innovative diamond** layouts to the **in-line layout** of the PX140, the aesthetic impact is very striking, yet more than this they have been designed to be **ergonomic for the user.**

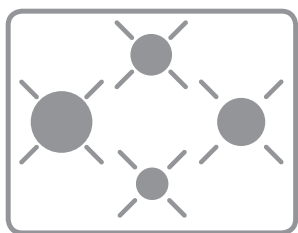

OPTIMUM SPACING FOR LARGER PANS

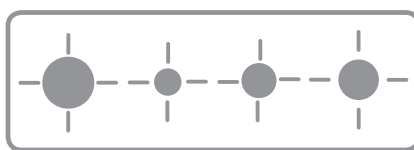

EASY ACCESS BURNERS

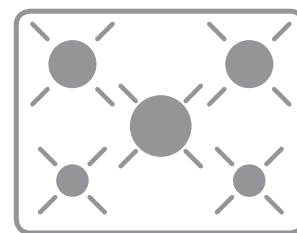

TRADITIONAL BURNER LAYOUT

## INTERCHANGEABLE AESTHETICS: CLASSIC TO LINEA

---



The PS906-4, all hobs with codes beginning PGF and all 30cm Domino hobs come fitted with Classic control knobs as standard. However, a set of Linea controls are also provided, giving the customer the option to change aesthetics depending on personal preference and the style of the rest of the kitchen.

COORDINATING DESIGNS



**PIANO DESIGN**  
**Architect styled** Piano Design hobs shown on pg.7, eye-catching statement pieces finished in polished stainless steel.



**NEWSON**  
**Designer** Newson hobs on pg.12 incorporate distinctive pan stands and elegant surfaces of stainless steel or glass.



**CORTINA**  
 The harmonious balance of features and the careful combination of materials characterise the **Cortina** aesthetics.



**LINEA**  
 Linea hobs respond to **modern design trends** and incorporate transparent controls that coordinate perfectly with Linea ovens.



**CLASSIC**  
 Classic hobs with **ergonomic** lever-style controls and smooth sleek lines are the ideal partners for Classic ovens.

EVERSHINE



New Piano hobs have an innovative invisible coating called Evershine. This treatment is applied to the surface of the pan stands and the tops of the burner caps to help prevent discolouration of the polished stainless steel. For specification information please see page 7

ELEGANT LINEA CERAMIC GLASS GAS HOBS



Smeg have added ceramic glass gas hobs to the range this year, comprised from a single piece of flat glass measuring just 4mm thick – perfect for contemporary and minimalist kitchens. The ceramic glass is able to resist heats of up to 800°C, making the hobs extremely robust, durable and user friendly. The pan stands are made from a single piece of cast iron and finished in white or black enamel, with no joins, providing easier cleaning. Flat enamel burners and colour co-ordinating control knobs complete the look.



GLASS-ON-STEEL, THE STRENGTH OF STAINLESS STEEL AND THE ELEGANCE OF GLASS



Glass-on-steel, a reinforced base, developed exclusively by Smeg, consists of a steel layer fixed to the underside of the glass surface of all **gas on glass hobs** in order to **increase their resistance**. This innovative but simple idea adds an **important safety feature** to the hobs. In the extreme eventuality that the glass of the hob is accidentally broken, a special adhesive paste between the glass and the steel holds the glass in place, avoiding dispersion of the glass, and allowing the continued use of the product in a safe environment until a replacement base can be fitted.

State of the art technology and sophisticated styling are principles found in all Smeg products, including hobs. With the benefits of quick response and simplicity of use, gas hobs are the perfect choice for the most discerning chef. A wide range of Linea and Classic gas hobs are offered throughout.

## FLEXIBLE USE BURNERS

Smeg's internal design studio have created burners with **unique style** and **superior performances**. From the smallest burners to powerful ultra-rapid burners (with up to **5kW of power**), Smeg offer a vast number of burner combinations and potency.



### DIRECTIONAL BURNERS

The directional flame is almost vertical; **real power** is transferred to the pot as the flames spread to match the diameter of the underside of the pan. This causes heat to concentrate, resulting in a **high performance burner** that cooks faster than a traditional gas burner.



### ULTRA RAPID BURNERS

These powerful burners offer up to 5kW of power, and are one of three designs: a triple flame burner or a dual flame burner with a single control, or a **dual flame 3-way burner**. Composed of an auxiliary and a rapid burner its 2 controls allow both parts of the burner to work together, or independently.

### SAFETY VALVES

Valves on the burner cut off the gas flow if the flame is accidentally extinguished. In this event, the gas feeder **valve shuts off immediately**, regardless of the position of the control.

## VISUAL GAS SAFETY SYSTEM



A number of Linea hobs have **innovative controls** which are illuminated when the burner is active.

The unique feature creates a visual gas safety system. Attention to functionality is the inspiration behind the design of the backlit controls, a design detail that is also a useful safety feature as, if you leave a burner on by mistake, even if there is no flame, the light stays on, but the gas is automatically switched off.



The majority of Smeg gas hobs have **heavy duty cast iron pan stands**, however there is also a choice of models with enamel or stainless steel pan stands.

## COOKING ACCESSORIES



A range of accessories allow Smeg hobs to become even more flexible. A special cast iron Wok support is designed for enthusiasts of oriental cuisine as it supports a wok perfectly, ideal for stir frying, and steaming. Further accessory details can be found on pages 122-123.

## INDUCTION: EFFICIENT TECHNOLOGY

Induction cooking is based on magnetic fields: each 'element' (an induction coil) generates a magnetic field that induces heat onto a ferrous material based pan.

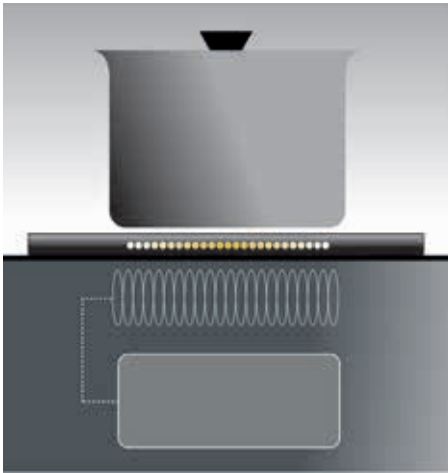

In essence the pot becomes the element that cooks the food, and as a consequence energy efficiency is maximized and heat loss is minimized as only the base of the pan is heated.

It means that the surface of the hob doesn't reach the temperatures of standard ceramic hobs. Another benefit of this is that any splashes will not burn onto the hob top and can be easily wiped away.



## DESIGNER INDUCTION

Marc Newson designed induction hobs are recognised for their distinctive use of colour, with exclusive design serigraphy. The commands mirror the positions of the induction zones, meaning that switching on each zone is very intuitive – the right control for the right burner can be selected in just one quick glance. Range details can be found on pages 13-15.

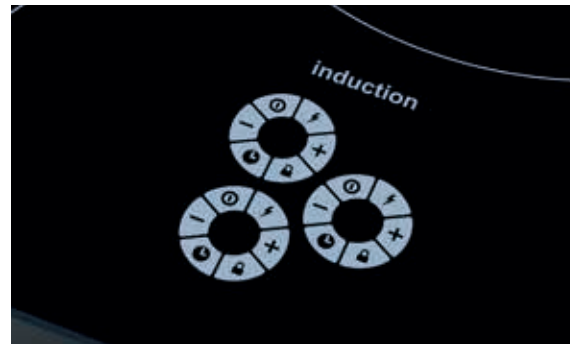

## INTELLIGENT ENGINEERING



This impressive technique is **faster than gas cooking** taking only a little over a minute to heat a pint of water, and the electronic controls offer **precise temperature control**. All induction hobs include a number of excellent features which are designed to give the best results including **Automatic pan recognition and pan size**, **protection against accidental start-up**, **auto-stop when no pan**, **overheating and/or overflow protection system**.

As an alternative to cooking with gas, Smeg offer Induction or Ceramic hobs. Extremely efficient and reliable, they cook much faster than traditional models. Both versions offer a combination of cooking zones including single, double (oval or circular) or giant zones.

## VERSATILE CERAMIC HOBS



The Smeg range of ceramic hobs incorporate the latest technology and many innovative features to enhance their performance quality. The aesthetics are designed to co-ordinate with the various oven styles offered and the highest quality and safety is assured by use of the best materials and stringent checks during the manufacturing process.



### Dual cooking zones

The majority of hobs offer dual cooking zones, either circular or oval, adding extra versatility to the specification, and optimum choice for the serious cook. The zones vary from the lowest output at only 0.8kW up to the super zones with an output of 2.4kW, which can be found in both the circular and oval shape.



The Smeg range also includes a hob with a giant zone for complete versatility.

## IMPRESSIVE FEATURES FOR CERAMIC AND INDUCTION HOBS

**Digital touch controls** offer extremely responsive temperature control and are situated along the front edge of all the hobs in order to maximize the cooking area. A hard wearing black glass called "Suprema" is featured throughout the Induction and Ceramic ranges, offering extreme resistance to heat as well as being easy to maintain.



**ULTRA LOW:** The temperature for this option is very low (about 60°C), making it ideal for melting chocolate or butter and simply to keep food warm.



**CHILD LOCK:** This safety feature locks the controls when they are not in use, providing added safety in the kitchen.



**POWER BOOSTER (P):** This option allows the zone to work at full power when it is necessary to cook foods that require very intense cooking.



**TIMER:** All models have a timer which automatically ends cooking after a preset time, with an **acoustic alarm**.



**ECO LOGIC:** Designed to significantly reduce energy consumption, on activating this option the operating power levels are automatically lowered to limit the total power consumption of the appliance. This saves the user money by greatly reducing energy use, which in turn helps the environment.



**QUICK START:** On ceramic hobs only: When this function is selected, the chosen temperature is reached faster. The heating element works at maximum power until the right temperature is reached. The power is then automatically decreased in order to maintain the correct temperature. This option can be selected together with another power level.

## MULTIZONE HOBS

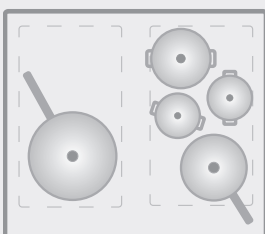

Unlike standard induction hobs which are divided into different cooking zones where size and position is restricted, these hobs have **large MultiZones** which can be divided into front and rear zones.

Each MultiZone **automatically detects the size and position** of the pots and pans, and heats up the exact spots where they stand, providing **optimum heat distribution and efficiency**. This allows several pans to be used at once, large or small, offering **freedom of placement** and greater flexibility.

## PV175CB

72CM 'LINEA' ULTRA LOW PROFILE GAS ON GLASS CERAMIC HOB,  
WHITE



5 burners  
Rear left: 1.70 kW  
Front left: 1.10 kW  
Centre: 3.50 kW  
Rear right: 2.60 kW  
Front right: 1.70 kW

Ultra low profile base  
Reinforced **glass-on-steel** base  
Removable enamelled heavy duty cast iron pan stands  
Flat enamelled burners

Automatic electronic ignition  
Safety valves  
Adaptable for LPG

NB: depth of hob c.4cm, and depth of glass raised above worktop  
c.4mm



PV175CN  
Black glass

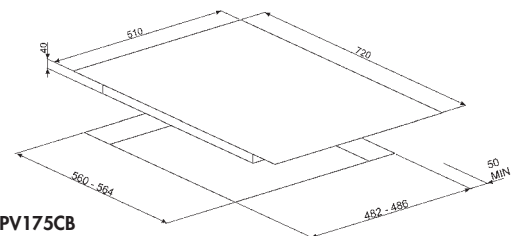

PV175CB  
PV175CN

## PV164CN

60CM 'LINEA' ULTRA LOW PROFILE GAS ON GLASS CERAMIC  
HOB, BLACK



4 burners  
Rear left: 1.70 kW  
Front left: 1.70 kW  
Rear right: 3.00 kW  
Front right: 1.10 kW

Ultra low profile base  
Reinforced **glass-on-steel** base  
Removable enamelled heavy duty cast iron pan stands  
Flat enamelled burners

Automatic electronic ignition  
Safety valves  
Adaptable for LPG

NB: depth of hob c.4cm, and depth of glass raised above  
worktop c.4mm



PV164CB  
White glass

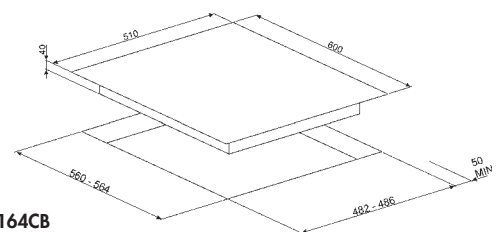

PV164CB  
PV164CN

# PX140

100CM "LINEA" ULTRA LOW PROFILE GAS HOB, ST/STEEL



4 burners  
Left: Ultra Rapid burner 4.20kW  
Centre Left: 1.05kW  
Centre Right: 1.70kW  
Right: 3.10kW

Ultra low profile base  
Illuminated controls  
Directional burners  
Removable cast iron pan stands

Automatic electronic ignition  
Safety valves  
Adaptable for LPG

NB: Depth of hob c. 6cm

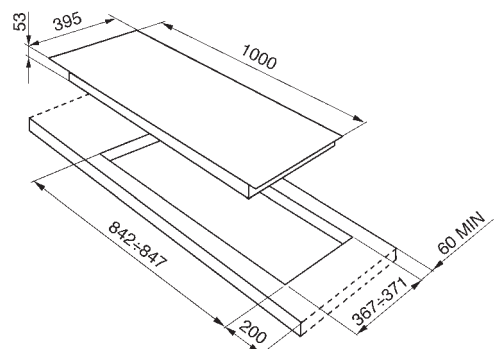

## PVN750

74CM 'LINEA' ULTRA LOW PROFILE GAS ON GLASS HOB, BLACK GLASS



5 burners  
Rear left: 1.70kW  
Front left: 1.05kW  
Centre: Ultra Rapid burner 5.00kW  
Rear right: 3.10kW  
Front right: 1.70kW

Ultra low profile base  
Reinforced **Glass-on-steel** base  
Illuminated controls  
Directional burners  
Removable cast iron pan stands

Automatic electronic ignition  
Safety valves  
Adaptable for LPG

NB: Depth of hob c. 6cm



PVS750  
Silver glass



PVB750  
white glass

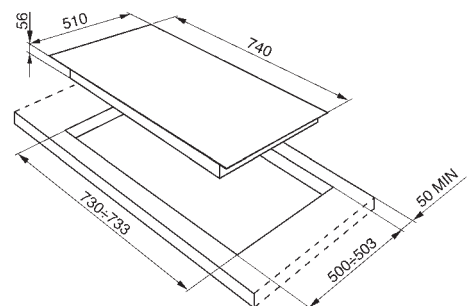

# PV175B

72CM 'LINEA' GAS ON GLASS HOB, WHITE GLASS



5 burners  
Rear left: 1.70kW  
Front left: 1.10kW  
Centre: Ultra Rapid burner 3.20 kW  
Rear right: 2.60 kW  
Front right: 1.70kW

Reinforced **Glass-on-steel** base  
Directional burners  
Heavy duty cast iron pan stands  
Black burner caps

Automatic electronic ignition  
Safety valves  
Adaptable for LPG



PV175N  
Black glass



PV175S  
Silver Glass

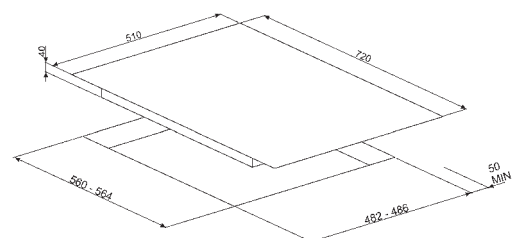

# PV164N

60CM 'LINEA' GAS ON GLASS HOB, BLACK GLASS



4 burners  
Rear left: 1.70kW  
Front left: 1.70 kW  
Rear right: 3.00kW  
Front right: 1.10kW

Reinforced **Glass-on-steel** base  
Directional burners  
Heavy duty cast iron pan stands  
Black burner caps

Automatic electronic ignition  
Safety valves  
Adaptable for LPG



PV164S  
Silver Glass

PV164B  
White Glass

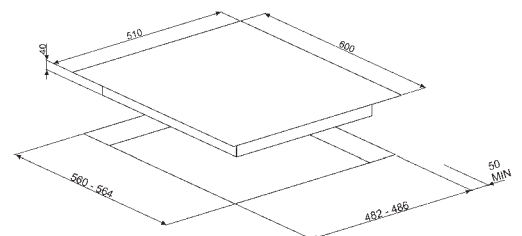

## P1752X

72.5CM LINEA GAS HOB, ST/STEEL



UR

5 burners  
Rear left: 2.55kW  
Front left: 1.05kW  
Centre: Ultra Rapid burner 4.10kW  
Rear right: 1.65 kW  
Front right: 1.65kW

### St/steel streamlined base

Transparent controls  
Heavy duty cast iron pan stands  
Black burner caps

Automatic electronic ignition  
Safety valves  
Adaptable for LPG

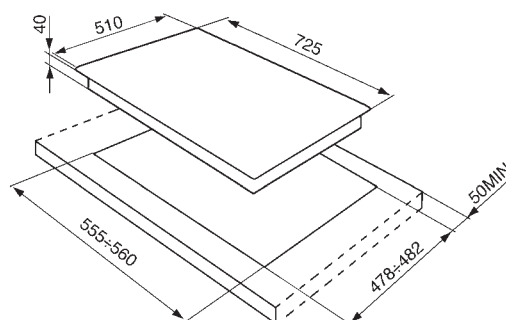

# P1640X

60CM LINEA GAS HOB, ST/STEEL



4 burners  
Left: 3.10kW  
Front centre: 1.05kW  
Rear centre: 1.65kW  
Right: 2.55kW

**St/steel streamlined base**  
Transparent controls  
Heavy duty cast iron pan stands  
Black burner caps

Automatic electronic ignition  
Safety valves  
Adaptable for LPG



**P1641X** SELECTED DEALERS  
Ultra rapid burner (3.60kW) on  
left replaces left burner (3.10kW)



**UR**

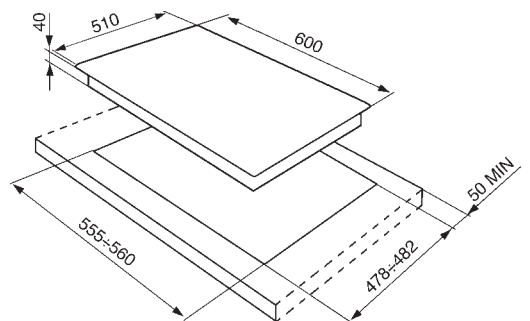

86CM ULTRA LOW PROFILE GAS HOB, ST/STEEL



6 burners

Front left Ultra Rapid burner: 4.00kW

Rear left: 1.05kW

Front centre: 1.05kW

Rear centre: 1.80kW

Front Right Ultra Rapid burner: 4.00kW

Rear right: 1.80kW

St/steel ultra low profile base

St/steel controls

Heavy duty cast iron pan stands

Black burner caps

STANDARD ACCESSORIES:

**Linea controls**

Automatic electronic ignition

Safety valves

Adaptable for LPG

*NB: This model has interchangeable aesthetics. It comes fitted with "Classic" controls, and "Linea" controls are provided as standard accessories.*

NB: depth of hob circa 7.9cm

Please note that an extra deep worktop is required should these hobs be fitted directly above an oven.

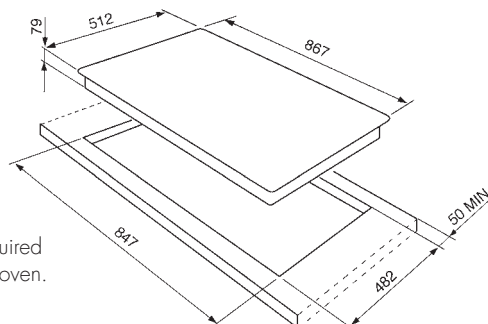



PGF96



5 burners  
 Left: Ultra Rapid dual flame 3-way burner 4.50 kW (3.60+0.90kW)  
 Rear centre: 2.50kW  
 Front centre: 1.05kW  
 Rear right: 2.50kW  
 Front right: 1.05kW

St/steel ultra low profile base  
 St/steel controls  
 Heavy duty cast iron pan stands  
 Black burner caps

STANDARD ACCESSORIES:  
**Linea controls**



Automatic electronic ignition  
 Safety Valves  
 Adaptable for LPG

*NB: This model has interchangeable aesthetics. It comes fitted with "Classic" controls, and "Linea" controls are provided as standard accessories.*

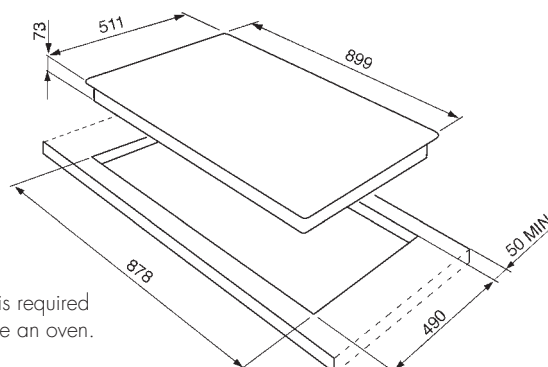

NB: depth of hob circa 7.9cm

Please note that an extra deep worktop is required should these hobs be fitted directly above an oven.

87CM ULTRA LOW PROFILE GAS HOB, ST/STEEL



5 burners  
 Rear left: 1.75kW  
 Front left: 1.75kW  
 Centre: Ultra Rapid burner 4.00kW  
 Rear right: 1.75kW  
 Front right: 1.05kW

St/steel ultra low profile base  
 St/steel controls  
 Heavy duty cast iron pan stands  
 Black burner caps

STANDARD ACCESSORIES:

**Linea controls**



Automatic electronic ignition  
 Safety valves  
 Adaptable for LPG  
 Pan rest incorporated in central pan stand

*NB: This model has interchangeable aesthetics. It comes fitted with "Classic" controls, and "Linea" controls are provided as standard accessories.*

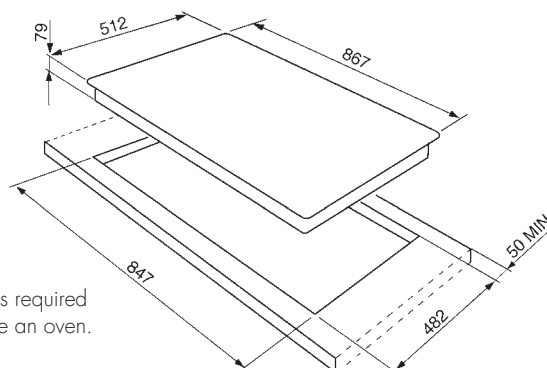

NB: depth of hob circa 7.9cm

Please note that an extra deep worktop is required should these hobs be fitted directly above an oven.



5 burners  
 Rear left: 1.75kW  
 Front left: 1.05kW  
 Centre: Ultra Rapid burner 4.00kW  
 Rear right: 1.75kW  
 Front right: 1.05kW

St/steel ultra low profile base  
 St/steel controls  
 Heavy duty cast iron pan stands  
 Black burner caps

STANDARD ACCESSORIES:

**Linea controls**



Automatic electronic ignition  
 Safety valves  
 Adaptable for LPG  
 Pan rest incorporated in central pan stand

*NB: This model has interchangeable aesthetics. It comes fitted with "Classic" controls, and "Linea" controls are provided as standard accessories.*

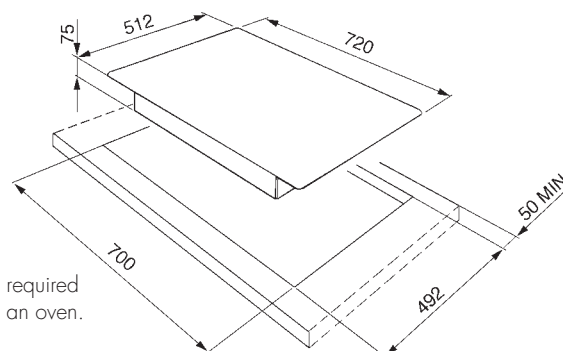

NB: depth of hob circa 7.9cm

Please note that an extra deep worktop is required should these hobs be fitted directly above an oven.

62CM ULTRA LOW PROFILE GAS HOB, ST/STEEL



4 burners in "diamond" configuration  
 Left: Ultra Rapid burner 4.00kW  
 Centre front: 1.05kW  
 Centre rear: 1.05kW  
 Right: 2.50kW

St/steel ultra low profile base  
 St/steel controls  
 Heavy duty cast iron pan stands  
 Black burner caps

STANDARD ACCESSORIES:

**Linea controls**



Automatic electronic ignition  
 Safety Valves  
 Adaptable for LPG

*NB: This model has interchangeable aesthetics. It comes fitted with "Classic" controls, and "Linea" controls are provided as standard accessories.*

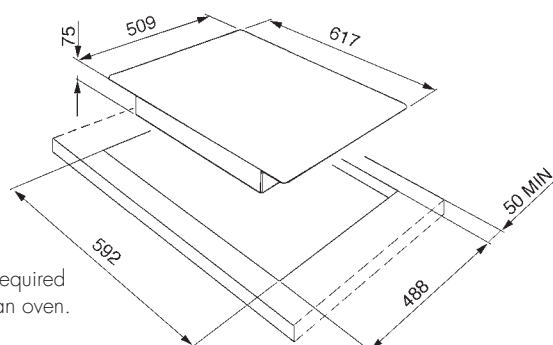

NB: depth of hob circa 7.9cm

Please note that an extra deep worktop is required should these hobs be fitted directly above an oven.

## PGF30B

30cm "DOMINO" ULTRA LOW  
PROFILE BARBECUE



Cast iron griddle

St/steel ultra low profile base  
St/steel control

STANDARD ACCESSORY:

**Linea control**



Nominal power: 1.8kW  
13 Amp power supply required

OPTIONAL EXTRA:

Connecting strip **LGPGF**

NB: Lava stone not included

## PGF32C

30cm "DOMINO" ULTRA LOW  
PROFILE CERAMIC HOB



2 High-light zones  
Front: Ø 1 x 140mm, 1.20kW  
Rear: Ø 1 x 180mm, 1.80kW

9 Power levels  
Residual heat indicators  
St/steel ultra low profile base  
St/steel controls

STANDARD ACCESSORY:

**Linea controls**



Nominal power: 3.00kW  
13 Amp power supply required

OPTIONAL EXTRA:

Connecting strip **LGPGF**

## PGF30F

30cm "DOMINO" ULTRA LOW  
PROFILE FRYER



Removable tank  
Tank with cold zone and  
emulsion zone  
Tank capacity: 3.6 Litres

Residual heat indicators  
St/steel ultra low profile base  
St/steel control  
St/steel cover

STANDARD ACCESSORY:

**Linea control**



Nominal power: 2.20kW  
13 Amp power supply required

OPTIONAL EXTRA:

Connecting strip **LGPGF**

## PGF32G

30cm "DOMINO" ULTRA LOW  
PROFILE GAS HOB



2 Burners  
Front: 1.05kW  
Rear: 2.30kW

St/steel ultra low profile base  
St/steel controls  
Heavy duty cast iron pan stands  
Black burner caps

STANDARD ACCESSORY:

**Linea controls**



Automatic electronic ignition  
Safety valves  
Adaptable for LPG

OPTIONAL EXTRA:

Connecting strip **LGPGF**

NB: All Domino hobs have interchangeable aesthetics. Each model comes fitted with "Classic" control/s, and "Linea" control/s are provided as standard accessories. Please also note that an extra deep worktop is required should these hobs be fitted directly above an oven.

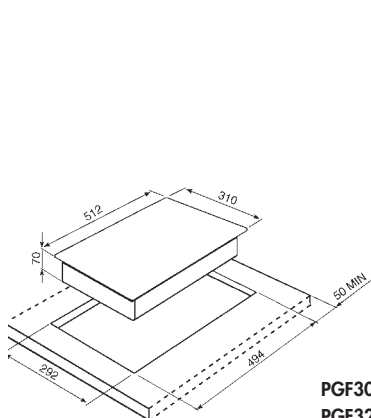

**PGF30B  
PGF32C  
PGF32G**

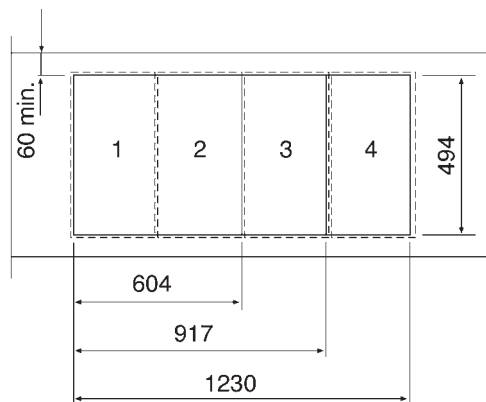

Cut-out dimensions for multiple domino hobs installed with connecting strips

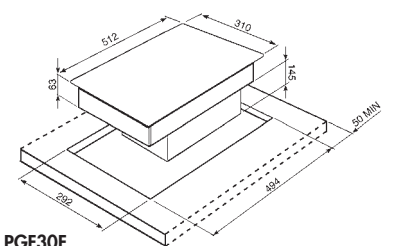

**PGF30F**

NB: depth of hob circa 7.9cm

## PGF31G-1

30cm "DOMINO" ULTRA LOW  
PROFILE GAS HOB



1 Ultra Rapid burner: 5.20kW  
St/steel ultra low profile base  
St/steel controls  
Heavy duty cast iron pan stand  
Black burner cap

STANDARD ACCESSORY:

**Linea controls**



Automatic electronic ignition  
Safety valves  
Adaptable for LPG

OPTIONAL EXTRA:  
Connecting strip **LGPGF**

## PGF30T-1

30cm "DOMINO" ULTRA LOW  
PROFILE TEPPANYAKI



2 independent temperature  
zones  
Front: 1.4kW – 1.8kW  
Rear: 1.4kW – 1.8kW

5 power levels  
Quick start  
Residual heat indicators  
St/steel ultra low profile base  
St/steel controls

STANDARD ACCESSORY:

**Linea controls**



Nominal power: 3.6kW  
30 Amp power supply required

OPTIONAL EXTRA:  
Connecting strip **LGPGF**

## PGF32I-1

30cm "DOMINO" ULTRA LOW  
PROFILE INDUCTION HOB



2 "full power" induction zones  
Front: Ø 140/100mm,  
1.4/2.5kW  
Rear: Ø 180/100mm,  
1.85/2.5kW

9 Power levels  
Residual heat indicators  
St/steel ultra low profile base  
St/steel controls

STANDARD ACCESSORY:

**Linea controls**



Nominal power: 3.00kW  
13 Amp power supply required

OPTIONAL EXTRA:  
Connecting strip **LGPGF**

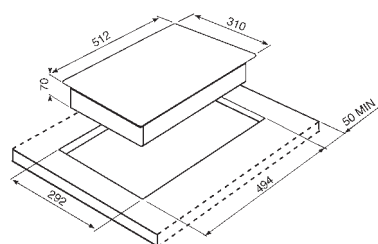

## SE70SGH-5

69CM "CLASSIC" GAS HOB, ST/STEEL



UR

5 burners  
Rear left: 2.55kW  
Front left: 1.05kW  
Centre: Ultra Rapid dual flame 3-way burner 4.95kW  
(3.90+1.05kW)  
Rear right: 1.65kW  
Front right: 1.65kW

St/steel base  
St/steel controls  
Heavy duty cast iron pan stands  
Black burner caps

Automatic electronic ignition  
Safety valves  
Adaptable for LPG

## SE70S-6

ENAMELLED PAN STANDS  
ULTRA RAPID BURNER (4.1kW)



UR

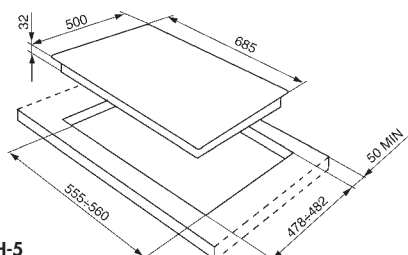

SE70SGH-5  
SE70S-6

## SER60S3

60CM "CLASSIC" GAS HOB, ST/STEEL



**UR**

4 burners in "diamond" configuration  
 Left: Ultra Rapid triple flame burner 4.00kW  
 Rear: 1.65kW  
 Front: 1.05kW  
 Right: 2.55kW

St/Steel base  
 St/steel controls  
 Enamelled pan stands  
 Black burner caps

Automatic electronic ignition  
 Safety valves  
 Adaptable for LPG

## SER60SGH3

HEAVY DUTY CAST IRON PAN STANDS



**UR**

## SE60SGH3

HEAVY DUTY CAST IRON PAN STANDS

RAPID BURNER (3.10kW) ON LEFT REPLACES ULTRA RAPID BURNER

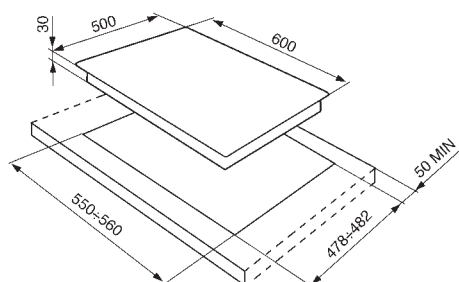

SER60S3  
 SER60SGH3  
 SE60SGH3

## SI3950B

90CM TOUCH CONTROL INDUCTION HOB WITH ANGLED EDGE GLASS

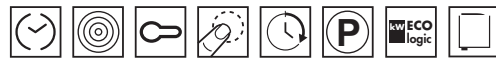

5 "full power" induction zones including:  
Rear left: Ø 230/100mm, 2.0kW – booster 3.1kW  
Front left: Ø 160/100mm, 1.4kW - booster 2.0kW  
Centre: Ø 280/100mm, 2.0kW – booster 3.6kW  
Rear right: Ø 230/100mm, 2.0kW – booster 3.1kW  
Front right: Ø 160/100mm, 1.4kW – booster 2.0kW

"Suprema" black ceramic glass  
5 independent boosters (P)  
Individual timers for each zone (1-99 minutes)  
9 power levels for each zone  
28cm Giant multi zone  
Visual display to show power level/residual heat/countdown cooking time  
**Auto pan recognition and adjustment to pan size**  
**Overheating and overflow protection system**  
**Protection against auto-start up**  
**Auto-stop when no pan**  
End of cooking acoustic alarm  
Automatic safety cut out  
Child safety lock

Nominal power: 10.8kW  
Consult a qualified electrician for power supply wiring requirements

NB: Only pans with a ferrous (magnetic) base  
are suitable for induction hobs

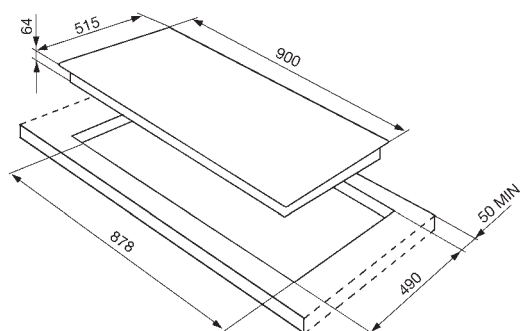

## SI3842B

77CM TOUCH CONTROL INDUCTION HOB WITH ANGLED EDGE GLASS

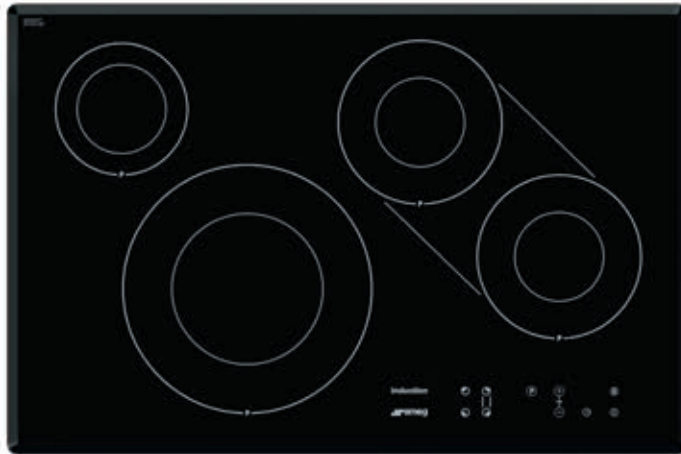

4 "full power" induction zones including:

Front centre:  $\varnothing$  280/100mm, 2.6kW – booster 3.7kW

Front left:  $\varnothing$  145/100mm, 1.4kW – booster 2.2kW

Rear right:  $\varnothing$  180/100mm, 1.8kW – booster 3.0kW

Front right:  $\varnothing$  180/100mm, 1.8kW – booster 3.0kW

Front and rear right zones can be combined to create a twin zone

"Suprema" black ceramic glass

4 independent boosters (P)

Individual timers for each zone

9 power levels

Visual display to show power level/ residual heat/  
countdown cooking time

Auto pan recognition and adjustment to pan size

Overheating and overflow protection system

Protection against auto-start up

End of cooking acoustic alarm

Automatic safety cut-out

Child safety lock

Nominal power: 7.4kW

Power supply required: dedicated circuit fused at 30 Amp, or a 32 Amp  
circuit breaker

NB: only pans with a ferrous (magnetic) base are suitable for induction hobs

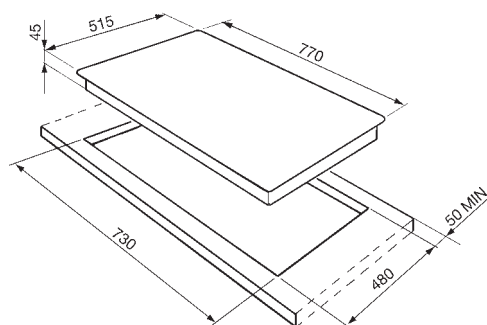

93CM TOUCH CONTROL INDUCTION HOB WITH ANGLED EDGE GLASS



4 "full power" induction zones including:

Left: Ø 230/200mm, 1.2kW – turbo 2.3kW

Left centre: Ø 230/200mm, 1.2kW – turbo 2.3kW

The two zones on the left can be combined to create one MultiZone:Ø 230/400mm, 2.4kW - turbo 4.6kW

Right centre: Ø 230/200mm, 1.2kW – turbo 2.3kW

Right: Ø 230/200mm, 1.2kW – turbo 2.3kW

The two zones on the right can be combined to create one MultiZone:Ø 230/400mm, 2.4kW – turbo 4.6kW

4 independent boosters (P)

Individual timers for each zone

12 power levels

Visual display to show power level/ residual heat/

Countdown cooking time

2 Quick set levels – for medium or low cooking

Auto pan recognition & adjustment to pan size

Overheating & overflow protection system

Protection against auto-start up

End of cooking acoustic alarm

Automatic safety cut-out

Child safety lock

Nominal power: 7.2kW

Power supply required: dedicated cooker circuit fused at 30 Amp, or a 32 Amp circuit breaker

NB: only pans with a ferrous (magnetic) base are suitable for induction hobs

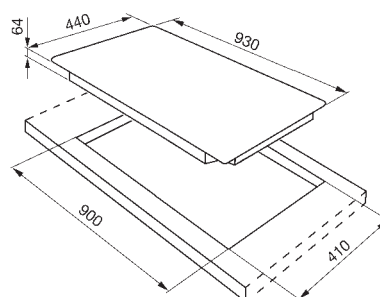

58CM TOUCH CONTROL INDUCTION HOB WITH ANGLED  
EDGE GLASS, BLACK GLASS



4 "full power" induction zones including:  
 Front Left: Ø 200/115mm, 0.5kW – booster 2.3kW  
 Rear Left Ø 200/115mm, 1.2Kw – booster 2.3kW  
 The two zones on the left can be combined to create  
 one MultiZone:Ø 400/230mm, 0.5kW -  
 booster 4.6kW  
 Rear right: Ø 200/115mm, 0.5kW – booster 2.3kW  
 Front right: Ø 200/115mm, 1.2Kw – booster 2.3kW  
 The two zones on the right can be combined to create  
 one MultiZone:Ø 400/230mm, 0.5kW –  
 booster 4.6kW

"Suprema" ceramic glass  
 4 independent boosters (P)  
 Individual timers for each zone  
 12 power levels  
 Visual display to show power level/ residual heat/  
 countdown cooking time  
 2 Quick set levels - for medium or low cooking  
 Pre heat mode  
 Auto pan recognition and adjustment to pan size  
 Overheating and overflow protection system  
 Protection against auto-start up  
 Auto-stop when no pan  
 End of cooking acoustic alarm  
 Automatic safety cut-out  
 Child safety lock

Nominal power: 7.2kW  
 Power supply required: dedicated cooker circuit fused at  
 30 Amp, or a 32 Amp circuit breaker

NB: only pans with a ferrous (magnetic) base are suitable  
 for induction hobs

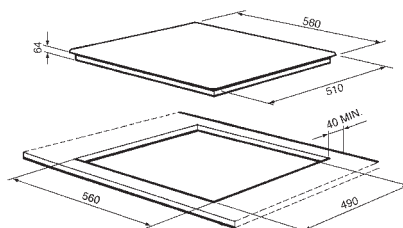

## SI4641CB

58CM TOUCH CONTROL INDUCTION HOB WITH ANGLED  
EDGE GLASS



4 "full power" induction zones including:  
 Front left: Ø 180/100mm, 2.2kW – booster 2.8kW  
 Rear left: Ø 180/100mm, 2.2kW – booster 2.8kW  
 Front right: Ø 160/100mm, 1.8kW – booster 2.2kW  
 Rear right: Ø 210/100mm, 2.4kW – booster 3.1kW

"Suprema" black ceramic glass  
 Circular slider control for individual power levels plus  
**(P) Booster** and 2 Quick set levels: for medium or low  
 cooking

4 independent boosters (P)  
 Individual timers for each zone  
 9 power levels  
 Visual display to show power level/ residual heat/  
 countdown cooking time  
**Auto pan recognition and adjustment to pan size**  
**Overheating and overflow protection system**  
**Protection against auto-start up**  
 End of cooking acoustic alarm  
 Automatic safety cut-out  
 Child safety lock

Nominal power: 7.2kW  
 Power supply required: dedicated cooker circuit fused at  
 30 Amp, or a 32 Amp circuit breaker

NB: only pans with a ferrous (magnetic) base are suitable  
 for induction hobs

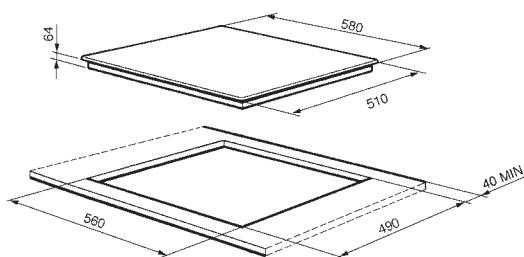

## SI3642B

60CM TOUCH CONTROL INDUCTION HOB WITH ANGLED  
EDGE GLASS



4 "full power" induction zones including:  
 Front left: Ø 180/100mm, 2.0kW – booster 2.8kW  
 Rear left: Ø 180/100mm, 2.0kW – booster 2.8kW  
 Front right: Ø 160/100mm, 1.4kW – booster 2.0kW  
 Rear right: Ø 230/100mm, 2.0kW – booster 3.1kW

"Suprema" black ceramic glass  
 4 independent boosters (P)  
 9 power levels  
 Visual display to show power level/ residual heat/  
 countdown cooking time  
**Auto pan recognition and adjustment to pan size**  
**Overheating and overflow protection system**  
**Protection against auto-start up**  
 End of cooking acoustic alarm  
 Automatic safety cut-out  
 Child safety lock

Nominal power: 6.2kW  
 Power supply required: dedicated circuit fused at  
 30 Amp, or a 32 Amp circuit breaker

NB: only pans with a ferrous (magnetic) base are suitable  
 for induction hobs

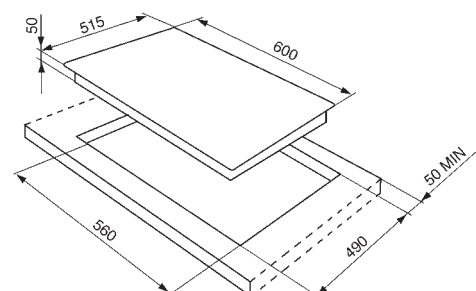

## SI3644D

58CM TOUCH CONTROL INDUCTION HOB WITH STRAIGHT EDGE GLASS, BLACK



4 "full power" induction zones including:  
 Front left: Ø 210/100mm, 1.85kW - booster 2.3kW  
 Rear left: Ø 180/100mm, 1.65kW - booster 2.3kW  
 Rear right: Ø 210/100mm, 1.8kW - booster 2.3kW  
 Front right: Ø 160/100mm, 1.25kW - booster 2.0kW

"Suprema" ceramic glass  
 4 independent boosters (P)  
 Individual timers for each zone  
 9 power levels  
 Visual display to show power level/ residual heat/  
 countdown cooking time  
**Auto pan recognition and adjustment to pan size**  
**Overheating and overflow protection system**  
**Protection against auto-start up**  
**Auto-stop when no pan**  
 End of cooking acoustic alarm  
 Automatic safety cut-out  
 Child safety lock

Nominal power: 7.2kW  
 Power supply required: dedicated circuit fused at  
 30 Amp, or a 32 Amp circuit breaker

NB: only pans with a ferrous (magnetic) base are suitable  
 for induction hobs

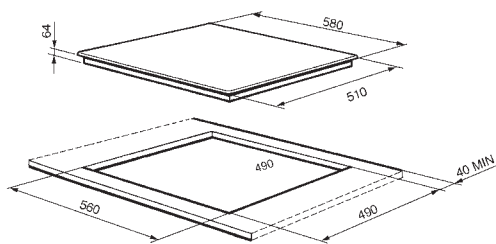

## SI3321B

30CM TOUCH CONTROL INDUCTION HOB WITH ANGLED EDGE GLASS, BLACK



2 "full power" induction zones including:  
 Rear: Ø 230/100mm, 2.0kW - booster 3.1kW  
 Front: Ø 160/100mm, 1.4kW - booster 2.0kW

"Suprema" black ceramic glass  
 2 Independent boosters (P)  
 Individual timer for larger zone (1-99mins)  
 9 power levels  
 Visual display to show power level/ residual heat/  
 countdown cooking time  
**Auto pan recognition and adjustment to pan size**  
**Overheating and overflow protection system**  
**Protection against auto-start up**  
**Auto-stop when no pan**  
 End of cooking acoustic alarm  
 Automatic safety cutout

Nominal power: 3.10kW  
 Power supply required: dedicated circuit fused at  
 30 Amp, or a 32 Amp circuit breaker

NB: Only pans with a ferrous (magnetic) base are  
 suitable for induction hobs

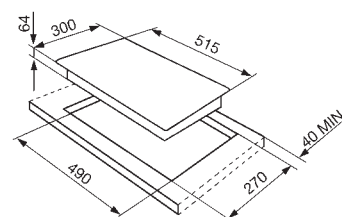

## SE2951TC2

90CM TOUCH CONTROL CERAMIC HOB WITH ANGLED EDGE GLASS



5 High-light radiant zones, including 1 dual and 1 triple:  
Rear left:  $\varnothing$  140mm, 1.2kW  
Front left dual zone:  $\varnothing$  140/180mm, 0.8/2.0kW  
Central:  $\varnothing$  140/210/270mm, 0.75/1.65/2.7kW  
Rear right:  $\varnothing$  195mm, 2.0kW  
Front right:  $\varnothing$  140mm, 1.2kW

"Suprema" black ceramic glass  
9 Power levels  
5 independent boosters(P)  
Individual timers for each zone  
27cm Giant zone

### Overheating and overflow protection system

Residual heat indicators  
End of cooking acoustic alarm  
Automatic safety cutout  
Child safety lock

Nominal power: 9.1kW

Consult a qualified electrician for power supply wiring requirements

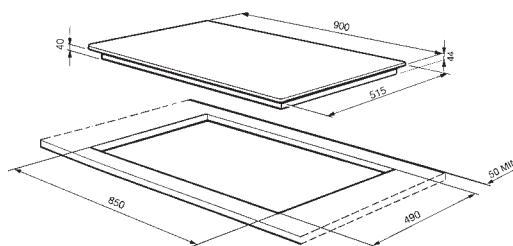



5 High-light radiant zones, including 2 dual:  
 Rear left: Ø 140mm, 1.2kW  
 Front left: Ø 180mm, 1.8kW  
 Central oval dual zone: Ø 170/265mm, 1.4/2.2kW  
 Rear right dual zone: Ø 140/210, 1.1/2.4kW  
 Front right: Ø 140mm, 1.2kW

"Suprema" black ceramic glass  
 9 Power levels  
 5 independent boosters(P)  
 Individual timers for each zone  
**Overheating and overflow protection system**  
 Residual heat indicators  
 End of cooking acoustic alarm  
 Automatic safety cut out  
 Child safety lock

Nominal power: 8.8kW  
 Consult a qualified electrician for power supply wiring requirements



SE2773TC2  
 Angled edge glass

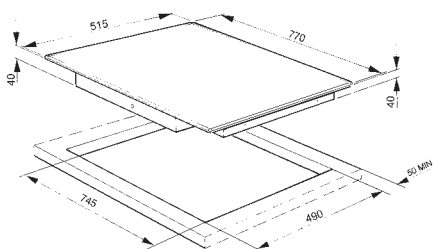

SE2773TC2

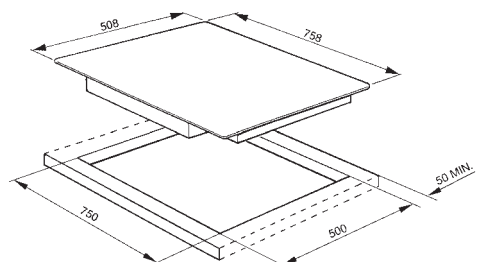

SE2773CX2

# SE2664CX2 WAFFER THIN FRAME

60CM TOUCH CONTROL CERAMIC HOB WITH WAFFER THIN FRAME



4 High-light radiant zones, including 2 dual:  
 Rear left: Ø 140mm, 1.2kW  
 Front left dual zone: Ø 120/180mm, 0.8/2.0kW  
 Rear right oval dual zone: Ø 170/265mm, 1.4/2.2kW  
 Front right: Ø 140mm, 1.2kW

"Suprema" black ceramic glass  
 9 Power levels  
 4 independent boosters(P)  
 Individual timers for each zone  
**Overheating and overflow protection system**  
 Residual heat indicators  
 End of cooking acoustic alarm  
 Automatic safety cut-out  
 Child safety lock

Nominal power: 6.6kW  
 Power supply required: dedicated circuit fused at 30 Amp, or a 32 Amp circuit breaker

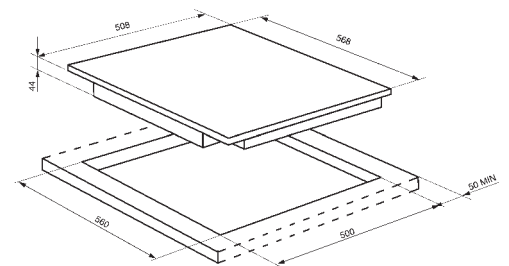

SE2664CX2

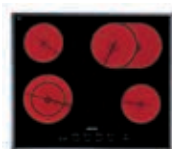

SE2664TC2  
 As above, with angled edge glass

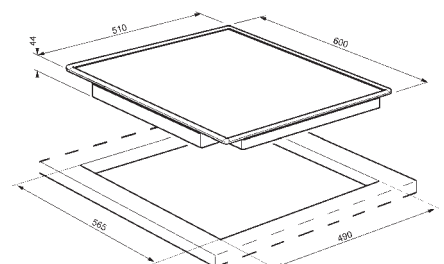

SE2664TC2

## SE2641TC2

60CM TOUCH CONTROL CERAMIC HOB WITH ANGLED EDGE GLASS

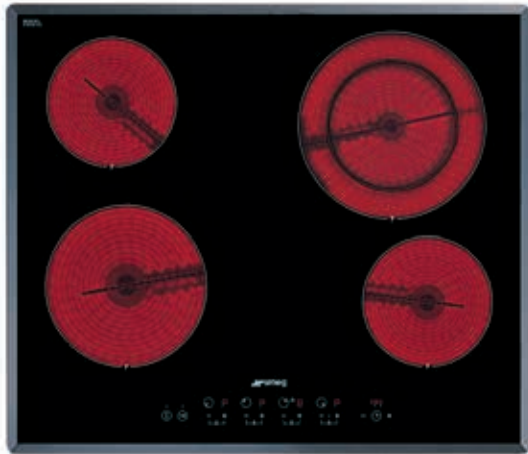

4 High-light radiant zones including 1 dual:  
 Rear left: Ø 140mm, 1.2kW  
 Front left: Ø 180mm, 1.8kW  
 Rear right dual zone: Ø 140/210mm, 1.1/2.4kW  
 Front right: Ø 140mm, 1.2kW

"Suprema" black ceramic glass  
 9 Power levels  
 4 independent boosters(P)  
 Individual timers for each zone  
**Overheating and overflow protection system**  
 Residual heat indicators  
 End of cooking acoustic alarm  
 Automatic safety cut-out  
 Child safety lock

Nominal power: 6.2kW  
 Power supply required: dedicated circuit fused at 30 Amp, or a 32 Amp circuit breaker

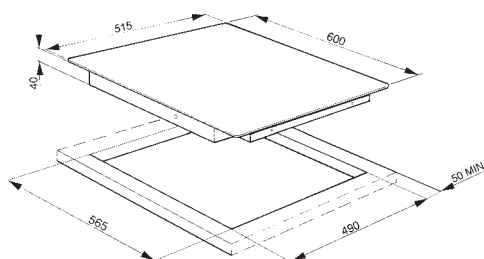

## SE2321TE2

30CM TOUCH CONTROL CERAMIC HOB WITH ANGLED EDGE GLASS



2 High-light radiant zones including 1 dual:  
 Front: Ø 140mm, 1.2kW  
 Rear dual zone: Ø 120/180mm, 0.8/2.0kW

"Suprema" black ceramic glass  
 9 Power levels  
 2 independent boosters(P)  
**Overheating and overflow protection system**  
 Residual heat indicators  
 Automatic safety cut-out  
 Child safety lock

Nominal power 3.2kW  
 Power supply required: dedicated circuit fused at 30 Amp, or a 32 Amp circuit breaker

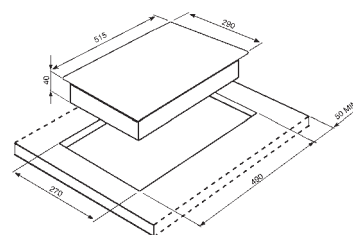

SMEG COOKERS,  
CHOOSING QUALITY



Smeg cookers are design icons, combining style and outstanding performance in every way.

## AN AMPLE RANGE

A passion for cooking deserves an outstanding cooker, with a harmonious blend of **practicality and style**. Inspired by the cookers used by the world's great chefs, Smeg offers genuine design icons where style and elegance go hand in hand with **extreme versatility**.

Available in a number of different dimensions from 60cm wide to 150cm, Smeg cookers are guaranteed to satisfy every space requirement.

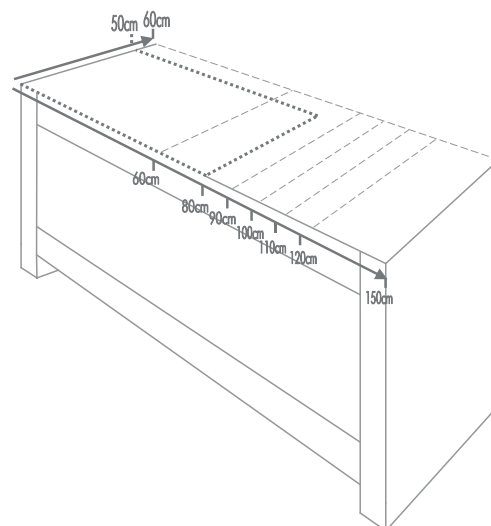

The range includes cookers with diverse capacities, from the smallest 35 litre capacity to an ample 80 litres. Choose from **single, double (horizontal or vertical) and triple ovens**, with a gas, ceramic or induction hob-top.

Smeg cookers can be elegantly slotted in between other fitted kitchen furniture for a distinctive choice that is totally safe, thanks to the **excellent insulation** and outer cooling system that prevents the sides of Smeg cookers from over-heating.

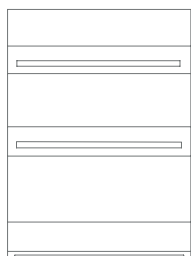

DOUBLE OVEN

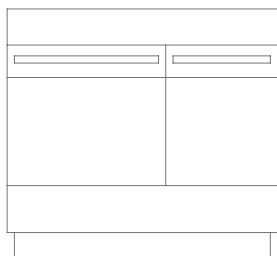

SIDE BY SIDE OVENS



## Colours and finishes

Smeg appliances are constantly in line with the latest design trends. All features are designed to **combine ease of use** with innovation and research. These cookers are appealing, practical yet distinctive and styled to enhance the appearance of modern kitchens. Various colour options allow you to select a cooker that will coordinate perfectly with your kitchen. Smeg cookers are available in gloss black, st/steel, pink, pale blue, red wine, silver or gloss cream finishes.



ST/STEEL



GLOSS BLACK



GLOSS CREAM



PINK



PASTEL BLUE



RED WINE



SILVER

## Low energy consumption



Most ovens in Smeg cookers are **A energy rated**, designed to perform at **maximum efficiency** while reducing energy consumption to the minimum. Models featuring the A-10% symbol can reduce energy consumption by a further 10% from the standard A Energy rating.

## GAS HOB TOPS

Spacious and practical, Smeg hob tops offer **multiple burner solutions** and can also be adapted for LPG.



### Contains spillages

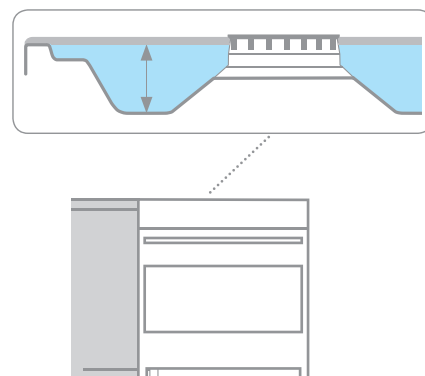

Gas hob tops each include at least one ultra rapid burner, an auxiliary burner and a mix of rapid and semi rapid burners. Ultra Rapid burners provide 3 solutions in 1, consisting of a double crown created by pairing a rapid burner with an auxiliary which function separately or together providing up to 4.5kW of power. Some models include an **elliptical burner** designed to cook fish, and many also feature a special **Teflon-coated cast iron griddle** - a genuine indoor barbecue! Just a little water under the plate stops food residues sticking to the st/steel underneath. All gas hobs have **safety valves**, and feature flat heavy duty cast iron pan stands.

In contrast to many traditional cookers, all Smeg hob tops have an **anti-overflow feature**, with the 90 cm models capable of holding 4.5 litres. This special feature avoids spills of liquid thus protecting the kitchen furniture on either side.

## Cooking accessories

A range of accessories helps make your Smeg cooker even more flexible. Please see pages 122-123 for a full list of accessories.



A special **wok support** is ideal for lovers of oriental cuisine as it supports a wok perfectly.



The teppanyaki grill plate offers a different cooking style option, using a hot plate to grill food and seal in the flavours.

## ELECTRIC HOB TOPS



### Induction hob

Induction hobs can be found within the Opera and Symphony ranges, and they have been teamed up with ovens with pyrolytic cleaning to make an outstanding combination. Ferrous based pans must be used for induction cooking, which means the surface of the hob is not heated, instead it only picks up residual heat from the pan base making cleaning so much easier and enables the hob top to remain **hygienically clean**. The **quick reaction** of the cooking zones and the increased safety of the cooking system make induction hobs a superb choice for professional cooking with **energy consumption reduced** to a minimum.



### Ceramic hob

Cookers with ceramic hobs can be found in the Symphony and Concert ranges in both 60 and 90cm widths. The varied heating zones range from a single 145mm diameter to a dual oval zone of between 190mm and 290mm, suitable for a fish kettle or large oval pan. The ceramic hobs have automatic safety cut-outs and individual residual heat indicators for all the cooking zones.

## FOCUS ON OVENS



The 60cm ovens have become either maxi plus 72 litres net (79 litres gross) or maxi 63 litres net (68 litres gross) and these offer considerable extra space in the oven and all feature a special base designed to take a pizza stone.



### Air cooling system



The fresh forced air recirculation system means that the door and its components inside the oven remain cool, ensuring greater safety and a longer life for your appliance. The cooling system remains in operation even when cooking is finished, continuing to function with the oven switched off, so as to dissipate the heat that has accumulated inside.

### Safe Cook



Closed door grilling and cooking is an important feature in Smeg ovens, keeping cooking smells inside the oven and out of the kitchen, ensuring a safe cooking environment and **reducing energy consumption**. This is made possible as Smeg incorporate its excellent air cooling system in all ovens and cookers. Many models include a switch which automatically turns off the power when the door is open, maintaining minimum energy consumption.

### Cleaning made simple

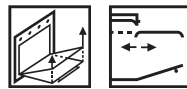

Many models feature the **all glass inner door**, with a completely flat surface to facilitate cleaning, and some models include two **removable inner door glasses**, which are easily detached for cleaning. A number of cookers have **removable roof liners**, which simply slide out for cleaning, and can even be put in the dishwasher.



Ovens with **pyrolytic cleaning** are becoming ever more popular, as consumers realise that they have free time to spend more usefully while the oven cleans itself automatically. A Smeg cooker with a single pyrolytic oven and a gas hob only requires a **standard 13 amp plug**, since it uses no more than 3 kW to complete the pyrolytic cleaning process.



Many models with the maxi cavity ovens which do not feature pyrolytic cleaning offer the Vapor Clean programme instead, which uses steam to loosen the deposits on the oven interior and at the end of the programme the cavity can be simply wiped clean.

### CUSTOM FIT



Most Symphony and Concert cookers are supplied with a set of 4 stainless steel adjustable feet and black metal plinth sections. The feet can be used alone, allowing the overall cooker height to vary between 880mm and 915mm, or if the standard 900mm height is required and the style of a sleek black plinth preferred, then the optional plinth sections can be fitted.

## COOKERS WITH REAL AESTHETIC APPEAL

Available in four different designs - **Opera**, **Victoria**, **Symphony** and **Concert** - all with their own **style-coordinated hood and splashbacks**, they present a complete item of furniture with which you can personalize your cook zone.



OPERA



VICTORIA



SYMPHONY



CONCERT

## OPERA COOKERS, STYLE LEADERS

Clever combinations of features, technology and style have produced the **truly versatile** series of Smeg Opera Cookers. The serious cook can select a beautiful design object to enhance the kitchen, which can reflect the skill of its owner by providing excellent culinary results from its **wealth of functions and features**.



The **stylish analogue clock** with electronic programming, as well as adding an exclusive touch of class, offers a convenient cooking solution, allowing you to program the start and stop of cooking times.



**Cast iron pan stands** for a stylish finish guarantee maximum safety with more stability so that pans can be easily moved from burner to burner.



Apart from the 90cm models with a single extra large 80 litre capacity oven, all Opera range cookers have two ovens. Main ovens are multifunction, with capacities between 63 and 80 litres, all featuring a **comprehensive choice of oven functions**. All auxiliary ovens feature grills and conventional cooking, while some models also offer a rotisserie and can be fitted with a plate rack as an accessory. Furthermore a spacious drawer under all ovens provides a convenient storage solution to tidy away kitchen utensils.

## VICTORIA COOKERS, PASSIONATE ABOUT TRADITION

Exclusive aesthetics, superb quality and unmistakable design are the ingredients that make any Smeg appliance unique. The Victoria is no exception. Inspired by the very first 'Elizabeth' model, this easy to use appliance **adds heart & soul** to the home.

The 110cm wide Victoria cooker offers 7 high performance gas burners, a fully variable grill with two cooking levels and two side opening oven compartments in addition to a storage drawer

The 90cm wide Victoria cooker offers 6 burners, a fully variable grill and two side opening oven compartments, one of which is a tall compartment with 7 shelf positions

Available in a variety of colours, the Victoria captures the essence of **timeless classic design**. Glass splashbacks and hoods are also available to complete the look.



Smeg's love of detail is shown through-out in such features as the signature **1950's retro branding on the upstand**, allowing co-ordination with other 50's style appliances, and light controls, useful for those with hand dexterity issues. The Victoria makes a great addition to any home.



## SYMPHONY COOKERS, THE PERFECT KITCHEN PARTNER

The aesthetic style of the Symphony range conveys the look and feel of a **specialist kitchen** in a domestic environment. By using Classic elements in its design, this range is **extremely versatile** and able to co-ordinate with a wide range of Smeg products.



The Symphony range is characterised by a contemporary and **distinctive square design**. Featuring distinctive **ergonomic control knobs** and stainless steel handles, this range is a clear extension of the Classic family. The cookers offer the ability to achieve excellent culinary results using an extensive **array of functions** and features that allow for simultaneous cooking of a diverse range of foods at varying temperatures.



The Symphony collection includes versions in 60cm and 90cm widths with gas, ceramic and induction hobs, in addition to the original 110cm 4 cavity range cooker.



This range is only available in Stainless Steel with the exception of the 110cm wide cooker and 90cm induction hob cooker which are also available in Gloss Black. Splash backs and hoods are also available to complete the look.



90cm and some 60cm models feature ovens with **Pyrolytic cleaning**, where dirt is burnt off during the cycle reducing it to a small pile of ash, wherever possible offering added convenience to the consumer. Models that don't have Pyrolytic cleaning have a **Vapor clean programme** instead, which uses steam to loosen dirt, making Symphony cookers very easy to keep clean. All Symphony cookers also feature a **removable roof liner** in the main oven, which simply slides out for cleaning, and can even be put in the dishwasher.

## CONCERT COOKERS, DISTINCTIVE DESIGN

---

This comprehensive collection of cookers combines **clean design lines** with high quality components and the result is a selection of appliances which are practical, **easy to use** and which produce excellent results for today's cook. The Concert selection offers models with single and double ovens in a variety of widths with extensive choices of hob type.



The Concert collection has a distinctive design with a softly rounded top, flat cast iron pan stands or ceramic hob, in a variety of widths and depths. Classic controls and solid stylish doors with characteristic Classic handles complete the design, which co-ordinates well with other Smeg appliances.



All the Concert cookers are available in the classic brushed Stainless Steel finish, and many are also offered in gloss black. The popular 90cm double oven dual fuel model illustrated below in Gloss Black has three colour options: Stainless Steel, Gloss Black and Gloss Cream. The 60cm double oven model is available in Stainless Steel or Gloss Black with a gas or ceramic hob.



All Concert cookers offer a range of oven cooking functions, which always includes Circulaire, a particularly **quick and efficient** method of cooking, ensuring even browning of food and saving energy. An **easy-to-use electronic clock and programmer** is standard on every Concert model.

The SUK61PX8 offers **Pyrolitic cleaning**, with a gas hob. This cooker has quadruple glazed doors and is A rated for energy efficiency. The exterior door temperature does not exceed 55°C during the Pyrolitic cleaning process and the flat all glass inner door avoids any inadvertent collection of food particles. **Pyrolitic cleaning is a great time saver for busy people.**

## COORDINATED COOK ZONE WITH GLASS SPLASHBACKS & UPSTANDS

---

The Smeg range includes a number of eye-catching glass splashbacks and upstands, they are available in 8 stunning colours and finishes chosen specifically to complement the Smeg product range and create a completely personalised cook zone with striking aesthetic impact.



# A5-8

150CM "OPERA" DUAL CAVITY COOKER WITH GAS HOB & ELECTRIC GRIDDLE, ST/STEEL



### MAIN OVEN:



9 functions Inc Circulaire element with fan



- Oven capacity: gross - 90 litres, net - 80 litres
- Analogue LED electronic clock/programmer
- Air cooling system
- Closed door grilling
- Triple glazed removable door
- Rotisserie
- Stay clean liners

### AUXILIARY OVEN:



8 functions Inc Circulaire element with fan



- Oven capacity: Gross 68 litres, net 58 litres
- Analogue LED electronic clock/programmer
- Triple glazed removable door
- Air cooling system
- Closed door grilling
- Special pizza cooking function
- Stay clean liners

Pull out full width storage drawer

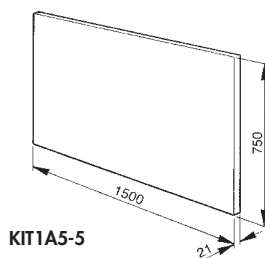

KIT1A5-5

### HOB:



7 Burners + Griddle

- Rear left: 1.80kW
- Front left: Ultra Rapid 4.2kW
- Rear left centre: Rapid 3.0kW
- Front left centre: 1.00kW
- Electric griddle: 1.60kW with Teflon coated plate
- Rear right centre: Fishburner 1.90kW
- Front right centre: 1.00kW
- Right centre: Ultra Rapid dual flame 3-way burner 4.5kW (3.5+1.0kW)
- Heavy duty cast iron pan stands
- Chrome wok support
- Automatic electronic ignition
- Safety valves
- Adaptable for LPG

Power supply required: dedicated cooker circuit fused at 40/45 amp

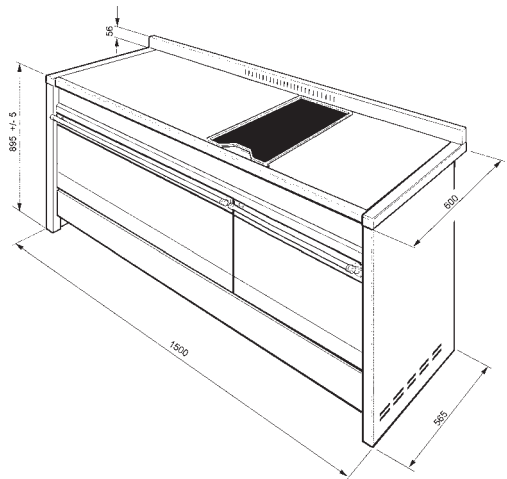

For additional information see pages 234-244

# A4BL-8

120CM "OPERA" DUAL CAVITY COOKER WITH GAS HOB & ELECTRIC GRIDDLE,  
GLOSS BLACK



**MAIN OVEN:**



9 functions Inc Circulaire element with fan



- Oven capacity: gross 68 litres, net 63 litres
- Analogue LED electronic clock/programmer
- Air cooling system
- Closed door grilling
- Triple glazed removable door
- Rotisserie
- Stay clean liners

**AUXILIARY OVEN:**



6 functions Inc Upper & lower element with fan



- Oven capacity: Gross 61 litres, net 58 litres
- Minute minder
- Air cooling system
- Closed door grilling
- Triple glazed removable door
- Special pizza cooking function
- Stay clean liners

Pull out full width storage drawer



A4-8  
St/steel

**HOB:**



6 Burners + Griddle

- Rear left: 1.80kW
- Front left: Ultra Rapid 4.2kW
- Rear centre: Rapid 3.0kW
- Front centre: 1.0 kW
- Electric griddle: 1.60kW with Teflon coated plate
- Rear right: Fishburner 1.90kW
- Front right: 1.0 kW
- Heavy duty cast iron pan stands
- Chrome wok support
- Automatic electronic ignition
- Safety valves
- Adaptable for LPG

Power supply required: dedicated cooker circuit fused at 30 amp or a 32 amp circuit breaker

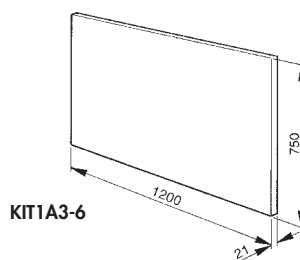

KIT1A3-6

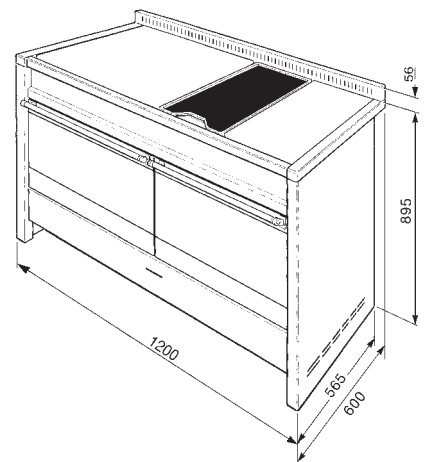

# A3-7

120CM "OPERA" DUAL CAVITY COOKER WITH GAS HOB & ELECTRIC GRIDDLE, ST/STEEL



### MAIN OVEN:



9 functions Inc Circulaire element with fan



Oven capacity: gross - 90 litres, net - 80 litres

Analogue LED electronic clock/programmer

Air cooling system

Closed door grilling

Triple glazed removable door

Rotisserie

Stay clean liners

### AUXILIARY OVEN:



4 functions Inc Upper & lower element



Oven capacity: gross - 42 litres, net - 41 litres

Air cooling system

Closed door grilling

Triple glazed removable door

Rotisserie

Variable grill

Pull out full width storage drawer beneath the ovens

### HOB:



6 Burners + Griddle

Rear left: 1.80kW

Front left: Ultra Rapid 4.2kW

Rear centre: Rapid 3.0kW

Front centre: 1.05kW

Electric griddle 1.60kW with Teflon coated plate

Rear right: Fishburner 1.90kW

Front right: 1.05kW

Heavy duty cast iron pan stands

Chrome wok support

Automatic electronic ignition

Safety valves

Adaptable for LPG

Power supply required: dedicated cooker circuit fused at 30 amp or a 32 amp circuit breaker

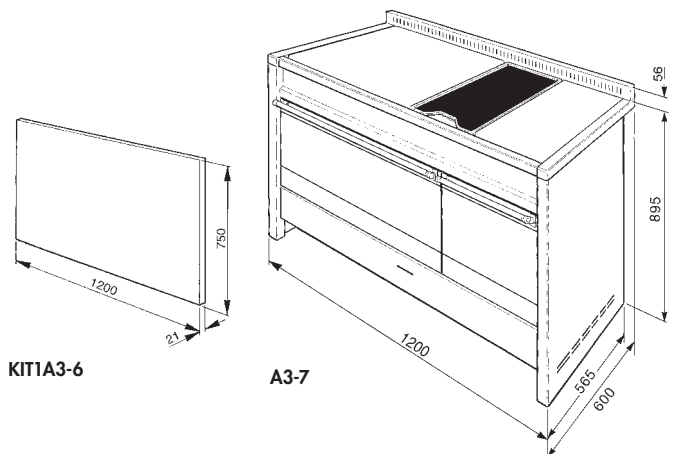

KITIA3-6

A3-7

For additional information see pages 234-244

## A2PYID-8

## PYROLITIC AND INDUCTION

100CM "OPERA" DUAL CAVITY COOKER WITH  
MULTIFUNCTION **Pyrolitic** OVEN & INDUCTION HOB, ST/STEEL



## A2PY-8

## PYROLITIC

100CM "OPERA" DUAL CAVITY COOKER WITH MULTIFUNCTION  
**Pyrolitic** OVEN & GAS HOB, ST/STEEL



### BOTH MODELS ON THIS PAGE:

#### MAIN OVEN:



10 functions Inc Circulaire element with fan  
Oven capacity: gross - 68 litres, net - 63 litres  
Analogue LED electronic clock/programmer  
Air cooling system  
Closed door grilling  
Quadruple glazed removable door  
Rotisserie  
**Pyrolitic cleaning**

#### AUXILIARY OVEN:



6 functions Inc Upper & lower element  
Oven capacity: gross - 39 litres, net - 35 litres  
Air cooling system  
Closed door grilling  
Triple glazed removable door  
Rotisserie

#### A2PYID-8 HOB:



5 'full power' induction zones including  
Right front: Ø 210 - 2.3 kW (booster 3.2 kW)  
Right rear: Ø 145 - 1.4 kW (booster 1.8 kW)  
Centre front: Ø 180 - 1.85 kW (booster 2.5 kW)  
Left rear: Ø 145 - 1.4 kW (booster 1.8 kW)  
Left front: Ø 210 - 2.3 kW (booster 3.2 kW)  
Electronic pan detector for each zone  
Low heat position on each zone to keep food warm  
Residual induction heat indicators  
Automatic safety cut-out

#### A2PY-8 HOB:



6 burners  
Rear left: Ultra Rapid 4.2kW  
Front left: 1.8kW  
Rear centre: 1.8kW  
Front centre: 1.0kW  
Rear right: Rapid 3.0kW  
Front right: Ultra Rapid 4.2kW  
Heavy duty cast iron pan stands  
Chrome wok support  
Automatic electronic ignition  
Safety valves  
Adaptable for LPG

#### POWER SUPPLY REQUIRED:

**A2PYID-8:** dedicated cooker circuit - consult a qualified electrician  
**A2PY-8:** dedicated cooker circuit fused at 30 amp or a 32 amp circuit breaker

Pull out full width storage drawer beneath the ovens

NB: **A2PYID-8** - Available while stocks last

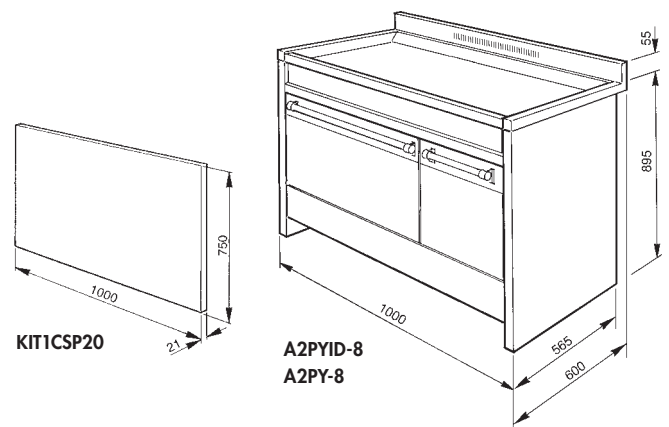

# A2BL-8

100CM "OPERA" DUAL CAVITY COOKER WITH MULTIFUNCTION OVEN & GAS HOB, GLOSS BLACK



### MAIN OVEN:



8 functions Inc Circulaire element with fan



Oven capacity: Gross 68 Litres, net 63 Litres  
 Analogue LED electronic clock/programmer  
 Air cooling system  
 Closed door grilling  
 Triple glazed removable door  
 Stay clean liners

### AUXILIARY OVEN:



6 functions Inc Upper & lower element



Oven capacity: gross - 39 litres, net - 35 litres  
 Air cooling system  
 Closed door grilling  
 Triple glazed removable door  
 Rotisserie

Pull out full width storage drawer beneath the ovens

### HOB:

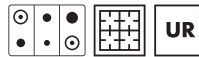

6 burners

Rear left: Ultra Rapid 4.2kW  
 Front left: 1.8kW  
 Rear centre: 1.8kW  
 Front centre: 1.00kW  
 Rear right: Rapid 3.0kW  
 Front right: Ultra Rapid 4.2kW  
 Heavy duty cast iron pan stands  
 Chrome wok support  
 Automatic electronic ignition  
 Safety valves  
 Adaptable for LPG

Power supply required: dedicated cooker circuit fused at 30 amp or a 32 amp circuit breaker



A2-8  
St/steel

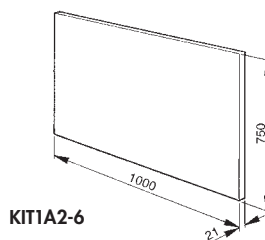

KIT1A2-6

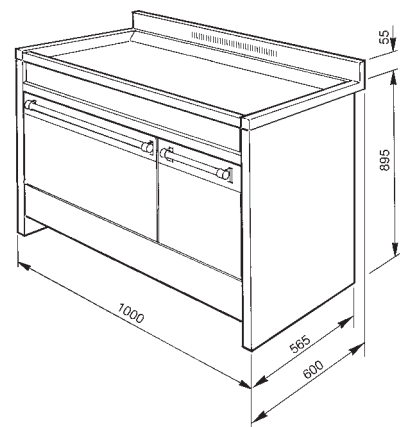

For additional information see pages 234-244

## A1P-9

90CM "OPERA" COOKER WITH MULTIFUNCTION OVEN & GAS HOB, GLOSS CREAM



OVEN:



9 functions Inc Circulaire element with fan



Oven capacity: gross - 90 litres, net - 80 litres

Analogue LED electronic clock/ programmer

Air cooling system

Closed door grilling

Triple glazed removable door

Rotisserie

Stay clean liners

Storage drawer beneath the oven

HOB:



6 burners

Rear left: Rapid 3.0kW

Front left: Ultra Rapid 4.2kW

Rear centre: Fishburner 1.9kW

Front centre: 1.05kW

Rear right: Rapid 3.0kW

Front right: 1.8kW

Heavy duty cast iron pan stands

Chrome wok support

Automatic electronic ignition

Safety valves

Adaptable for LPG

Power supply required: 13 Amp fused plug



A1-7  
St/steel



A1BL-7  
Gloss black

## A1PYID-7 PYROLITIC AND INDUCTION

90CM "OPERA" COOKER WITH PYROLITIC MULTIFUNCTION OVEN & INDUCTION HOB, ST/STEEL



OVEN:

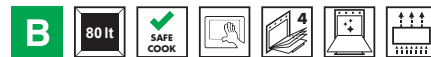

10 functions Inc Circulaire element with fan



Oven capacity: gross - 90 litres, net - 80 litres

Analogue LED electronic clock/ programmer

Air cooling system

Closed door grilling

Quadruple glazed removable door

Rotisserie

Pyrolytic cleaning

Storage drawer beneath the oven

HOB:



5 "full power" induction zones, including

Right front: Ø 145 - 1.1 kW (booster 2.2 kW)

Right rear: Ø 210 - 2.3 kW (booster 3.7 kW)

Centre front: Ø 260 - 2.4 kW (booster 3.7 kW)

Left rear: Ø 180 - 1.85 kW (booster 3.0 kW)

Left front: Ø 145 - 1.1 kW (booster 2.2 kW)

Automatic safety cut-out

Residual heat indicators

Low heat position on each zone for keeping food warm

Power supply required: dedicated cooker circuit - consult a qualified electrician

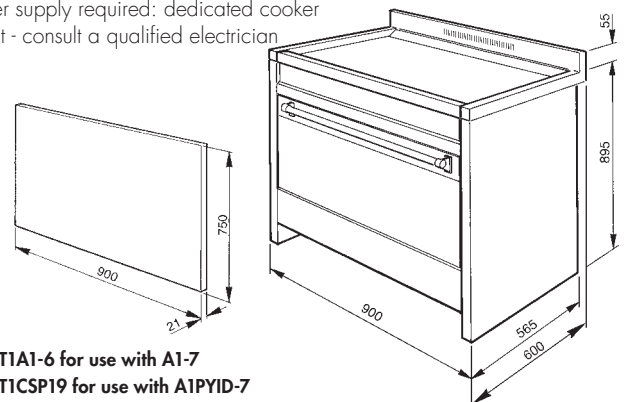

KIT1A1-6 for use with A1-7  
KIT1CSP19 for use with A1PYID-7

# TR4110BL1

110cm "VICTORIA" TRADITIONAL DUAL FUEL FOUR CAVITY RANGE COOKER & GAS HOB, GLOSS BLACK



TR4110P1  
Gloss cream



TR4110RWF  
Red Wine



TR4110SF  
Silver



TR4110RO  
Pastel Pink



TR4110AZ  
Pastel Blue

**MAIN OVEN: TOP RIGHT**



7 functions Inc Circulaire element with fan:



Oven capacity: gross 68 litres, net 63 litres  
Digital electronic clock / programmer

**Side opening door**

- Air cooling system
- Closed door grilling
- Triple glazed door
- Vapor clean function

**AUXILIARY OVEN: LOWER LEFT**



6 functions Inc upper & lower element with fan:



Oven capacity: gross 68 litres, net 63 litres

**Side opening door**

- Air cooling system
- Closed door grilling
- Triple glazed door

**GRILL COMPARTMENT: TOP LEFT**



Capacity: gross 39 litres, net 35 litres

- Air cooling system
- Closed door grilling
- Full variable grill
- Max grill power: 2.7kW

Storage drawer: Lower right  
Internal dimensions:  
H 140 W 420 x D 400 mm

**Hob:**

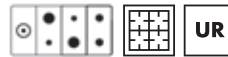

7 burners

- Front right: 1.80 kW
- Rear right: 1.80 kW
- Front centre: 3.00 kW
- Rear centre: 1.00 kW
- Front left: 1.00 kW
- Rear left: 3.00 kW
- Far left: Ultra rapid burner: 4.20 kW
- Heavy duty cast iron pan stands
- Automatic electronic ignition
- Safety valves
- Adaptable for LPG

Power supply required: dedicated cooker circuit fused at 40/45 amp

**NB:** These models are only available from selected dealers. For stockist details please see the website [www.smeguk.com](http://www.smeguk.com).

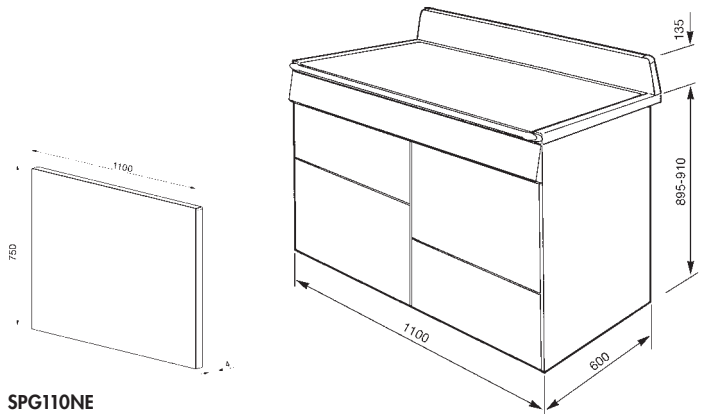

SPG110NE  
SPG110P

For additional information see pages 234-244



TR4110P1  
SPG110NE  
KT110P  
TPKTR

TR93P

90CM "VICTORIA" TRADITIONAL DUAL FUEL THREE CAVITY RANGE COOKER & GAS HOB, GLOSS CREAM



MAIN OVEN: BOTTOM LEFT



7 functions Inc Circulaire element with fan:



- Oven capacity: gross 68 litres, net 63 litres
- Digital electronic clock / programmer
- Side opening door
- Air cooling system
- Closed door grilling
- Triple glazed door
- Vapor clean function

AUXILIARY OVEN: RIGHT

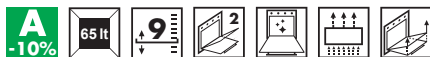

Circulaire element with fan:



- Oven capacity: gross 68 litres, net 65 litres
- Side opening door
- Air cooling system
- Triple glazed door

GRILL COMPARTMENT: TOP LEFT



- Capacity: gross 41 litres, net 36 litres
- Air cooling system
- Closed door grilling
- Full variable grill
- Max grill power: 2.7kW

TR93BL

90CM "VICTORIA" TRADITIONAL DUAL FUEL THREE CAVITY RANGE COOKER & GAS HOB, GLOSS BLACK



Hob:

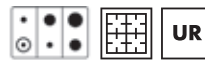

- 6 burners
- Front right: 1.80 kW
- Rear right: 2.90 kW
- Front centre: 1.00 kW
- Rear centre: 1.80 kW
- Front left: Ultra rapid burner 4.20 kW
- Rear left: 1.00 kW
- Heavy duty cast iron pan stands
- Automatic electronic ignition
- Safety valves
- Adaptable for LPG

Power supply required: dedicated cooker circuit fused at 40/45 amp

NB: These models are only available from selected dealers. For stockist details please see the website [www.smeguk.com](http://www.smeguk.com).

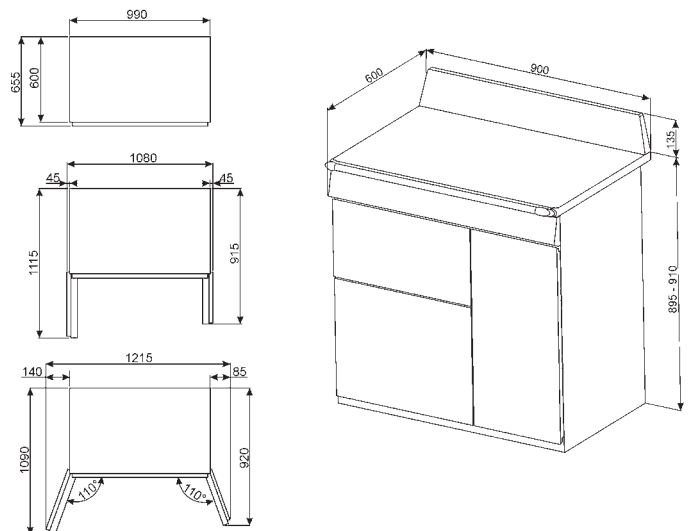

For additional information see pages 234-244



**TR93P  
KT90P**

# SY4110BL8

110CM "SYMPHONY" DUAL FUEL FOUR CAVITY RANGE COOKER & GAS HOB,  
GLOSS BLACK



## MAIN OVEN - TOP RIGHT:



7 functions Inc Circulaire element with fan



Oven capacity: gross 68 litres, net 63 litres  
Digital electronic clock/programmer  
Air cooling system  
Closed door grilling  
Double glazed removable door  
Vapor Clean

## AUXILIARY OVEN - LOWER LEFT:



6 functions Inc Upper & lower element with fan



Oven capacity: gross 68 litres, net 63 litres  
Air cooling system  
Closed door grilling  
Double glazed removable door

## GRILL COMPARTMENT - TOP LEFT:



Capacity: gross 39 litres, net 35 litres  
Air cooling system  
Closed door grilling  
Full variable grill  
Double glazed removable door  
Max grill power: 2.7kW

Storage drawer - lower right:

Internal dimensions:  
H160 x W375 x D390mm

## Hob:



6 burners

Rear left: 1.00kW  
Front left: Ultra Rapid burner 4.0kW  
Rear Centre: 1.75kW  
Front Centre: 1.00kW  
Rear right: Rapid burner 3.00kW  
Front right: 1.75kW  
Warming zone 130°C  
Heavy duty cast iron pan stands  
Automatic electronic ignition  
Safety valves  
Adaptable for LPG

Power supply required: dedicated cooker circuit fused at 40/45 amp

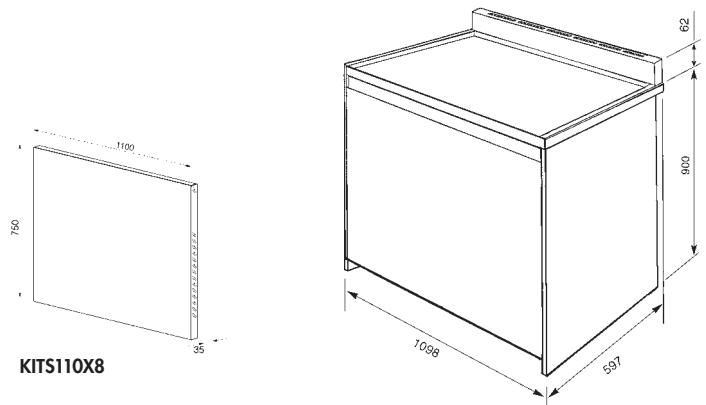

For additional information see pages 234-244



**SY4110-8  
KITS110X8  
KSE110X**

# SY92IPX8

# PYROLITIC AND INDUCTION

90CM 'SYMPHONY' DUAL CAVITY COOKER WITH MULTIFUNCTION PYROLITIC OVEN AND INDUCTION HOB, ST/STEEL



Photo shows legs & plinth fitted

BOTH MODELS THIS PAGE:

MAIN OVEN:



10 functions Inc Circulaire element with fan



Oven capacity: gross 79 litres, net 72 litres

Digital electronic clock/programmer

Air cooling system

Closed door grilling

Removable roof liner

Removable inner door glasses

Quadruple glazed removable door

Rotisserie

Pyrolitic cleaning

AUXILIARY OVEN:



4 functions Inc Upper & lower element



Oven capacity: gross - 39 litres, net - 35 litres

Air cooling system

Closed door grilling

Storage compartment beneath the ovens

St/steel feet and black plinth provided



SY92IPB18  
Gloss Black

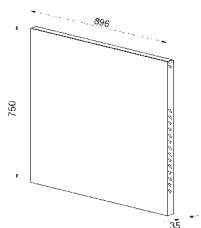

SY92IPX8 - Splashback KITC9X  
SY92PX8 - Splashback KITC9X  
SY92IPB18 - Splashback KITC9X

# SY92PX8

# PYROLITIC

90CM 'SYMPHONY' DUAL CAVITY COOKER WITH MULTIFUNCTION PYROLITIC OVEN AND GAS HOB, ST/STEEL



Photo shows legs only fitted

SY92IPX8 HOB:



5 full power induction zones

Rear left: Ø 180mm, 1.85 kW (booster 3.0kW)

Front left: Ø 145mm, 1.1 kW (booster 2.2 kW)

Centre: Ø 260mm, 2.4 kW (booster 3.7 kW)

Rear right: Ø 210mm, 2.3 kW (booster 3.7 kW)

Front right: Ø 145mm, 1.1 kW (booster 2.2 kW)

Power supplies required:

SY92IPX8: dedicated cooker circuit - consult a qualified electrician

SY92PX8: dedicated cooker circuit fused at 30 Amp, or a 32 Amp circuit breaker

SY92PX8 HOB



6 burners

Rear left: 1.0kW

Front left: Ultra Rapid 4.0kW

Rear Centre: 1.75kW

Front Centre: 1.0kW

Rear right: Rapid 3.0kW

Front right: 1.75kW

Heavy duty cast iron pan stands

Safety valves

Automatic ignition

Adaptable for LPG

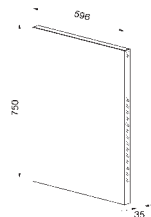

SY62MX8 - Splashback KITC6X  
SY6CPX8 - Splashback KITC6X

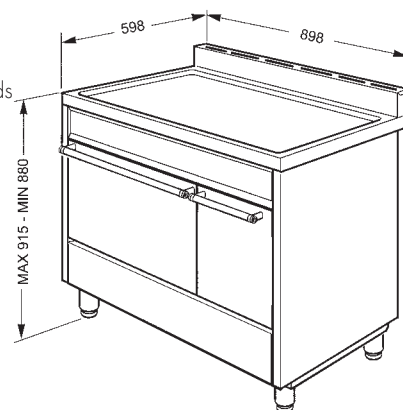

NB: Height with plinth installed is fixed at 900mm

For additional information see pages 234-244

## SY62MX8

60CM 'SYMPHONY' COOKER WITH DOUBLE OVEN AND GAS HOB,  
ST/STEEL



### MAIN OVEN:



7 functions Inc Circulaire element with fan



Oven capacity: gross - 68 litres, net - 63 litres

Digital electronic clock/programmer

Air cooling system

Closed door grilling

Removable roof liner

**Removable inner door glasses**

Double glazed removable door

Vapor clean

### AUXILIARY OVEN:



4 functions Inc Upper & lower element



Oven capacity: Gross 40 litres, net 36 litres

Air cooling system

Closed door grilling

Removable roof liner

Double glazed removable door

### HOB:



4 burners

Rear left: 1.8kW

Front left: Ultra Rapid 4.0kW

Rear right: 1.8kW

Front right: 1.0kW

Heavy duty cast iron pan stands

Safety valves

Automatic ignition

Adaptable for LPG

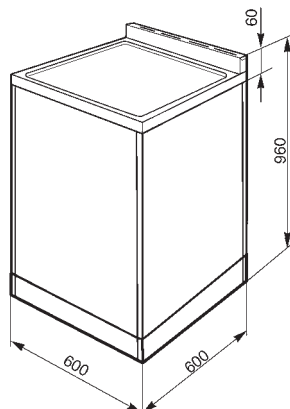

Power supply required: dedicated cooker circuit fused at 30 Amp,  
or a 32 Amp circuit breaker

## SY6CPX8

## PYROLITIC

60CM 'SYMPHONY' COOKER WITH PYROLITIC OVEN AND  
CERAMIC HOB, ST/STEEL



*Photo shows legs & plinth fitted*

### OVEN:



10 functions Inc Circulaire element with fan



Oven capacity: gross - 79 litres, net - 72 litres

Digital electronic clock/programmer

Air cooling system

Removable roof liner

Closed door grilling

**Removable inner door glasses**

Quadruple glazed removable door

**Pyrolytic cleaning**

Storage compartment beneath the oven

St/steel feet and black plinth provided

### HOB:



4 Highlight radiant zones, including 2 dual zones

Rear left: Ø 145mm, 1.2 kW

Front left dual zone: Ø 120/210mm, 0.75/2.2 kW

Rear right dual zone: Ø 170/265mm, 1.4/2.2 kW

Front right: Ø 180mm,

1.8 kW

Residual heat indicators

Automatic safety cut-out

Power supply required:  
dedicated cooker circuit -  
consult a qualified electrician

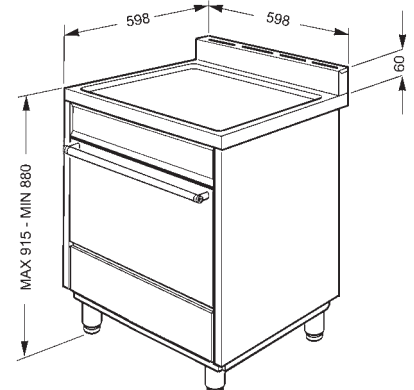

# SUK92P9-1

90CM "CONCERT" COOKER WITH DOUBLE OVEN & GAS HOB, GLOSS CREAM



Photo shows legs & plinth fitted

## MAIN OVEN:

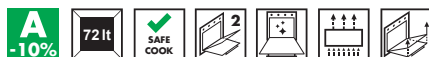

7 functions Inc Circulaire element with fan



Oven capacity: gross - 79 litres, net - 72 litres

Digital electronic clock/programmer

Air cooling system

Closed door grilling

Removable inner door glasses

Vapor clean

## AUXILIARY OVEN:



4 functions Inc Upper & lower element



Oven capacity: gross - 39 litres, net - 35 litres

Air cooling system

Closed door grilling

Storage compartment beneath the ovens

St/steel feet and black plinth provided

## HOB:



5 burners

Rear left: 1.8kW

Front left: Rapid 3.0kW

Centre: Ultra Rapid 3.5kW

Rear right: 1.8kW

Front right: 1.0kW

Heavy duty cast iron pan stands

Automatic electronic ignition

Safety valves

Adaptable for LPG

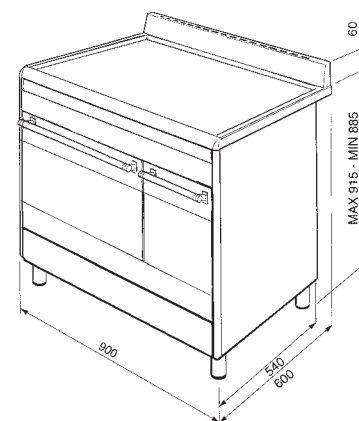

NB: Height with plinth installed is fixed at 900mm

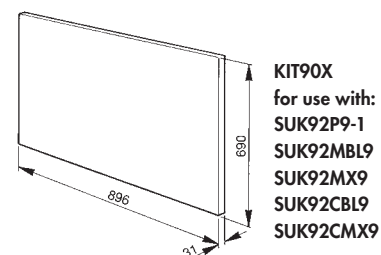

**KIT90X**  
for use with:  
SUK92P9-1  
SUK92MBL9  
SUK92MX9  
SUK92CBL9  
SUK92CMX9



SUK92MBL9  
Gloss black



SUK92MX9  
St/steel

# SUK92CBL9

90CM "CONCERT" COOKER WITH DOUBLE OVEN & CERAMIC HOB,  
GLOSS BLACK



Photo shows legs only fitted

## MAIN OVEN:



7 functions Inc Circulaire element with fan



Oven capacity: gross - 79 litres, net - 72 litres

Digital electronic clock/programmer

Air cooling system

Closed door grilling

Removable inner door glasses

Vapor Clean

## AUXILIARY OVEN:



4 functions Inc Upper & lower element



Oven capacity: gross - 39 litres, net - 35 litres

Air cooling system

Closed door grilling

Double storage compartment beneath the ovens

St/steel feet and black plinth provided

## HOB:



5 radiant 'High-Light' zones, including 2 dual

Rear left: Ø 195mm, 2.0kW

Front left: Ø 140mm, 1.2kW

Central dual zone: Ø 170/265mm, 1.4/2.2kW

Rear right dual zone: Ø 140/210mm, 0.75/2.2kW

Front right: Ø 140mm, 1.2kW

Residual heat indicators

Automatic safety cut-out

Power supply required: dedicated cooker circuit - consult a qualified electrician

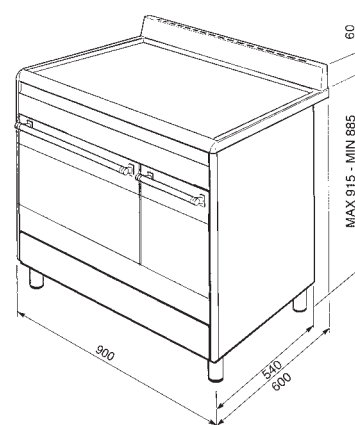

NB. Height with plinth installed is fixed at 900mm



SUK92CMX9  
Si/steel

For additional information see pages 234-244

## SUK62MX8

60CM "CONCERT" COOKER WITH DOUBLE OVEN & GAS HOB, ST/STEEL



## SUK62CBL8

60CM "CONCERT" COOKER WITH DOUBLE OVEN & CERAMIC HOB, GLOSS BLACK



BOTH MODELS THIS PAGE:

MAIN FAN OVEN:



Circulaire element with fan

Oven capacity: gross - 70 litres, net - 68 litres  
Digital electronic clock/programmer  
Air cooling system  
Removable inner door glass

AUXILIARY OVEN:



4 functions Inc Upper & lower element



Oven capacity: gross 40 litres, net 36 litres  
Air cooling system  
Closed door grilling

SUK62MX8 HOB:



4 burners  
Rear left: 1.8kW  
Front left: Ultra Rapid 4.0kW  
Rear right: 1.8kW  
Front right: 1.0kW  
Heavy duty cast iron pan stands  
Safety valves  
Automatic electronic ignition  
Adaptable for LPG

SUK62MX8 Power supply required:  
dedicated cooker circuit fused at  
30 Amp, or a 32 Amp circuit breaker



SUK62MBL8  
Gloss black

SUK62CBL8 HOB:



4 "High-Light" cooking zones including one  
2-way circular zone  
and one oval dual zone  
Rear left: Ø 145mm, 1.2kW  
Front left: Ø 120/210mm, 0.75/2.2kW  
Rear right: Ø 170/265mm, 1.4/2.2kW  
Front right: Ø 180mm, 1.8kW  
Residual heat indicators

SUK62CBL8 Power supply required: dedicated cooker  
circuit - consult a qualified electrician

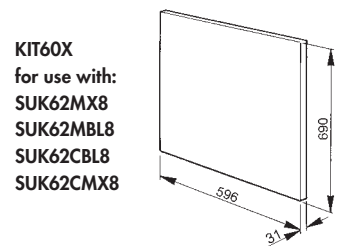

**KIT60X**  
for use with:  
SUK62MX8  
SUK62MBL8  
SUK62CBL8  
SUK62CMX8

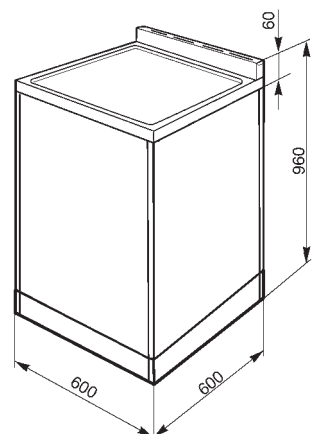

SUK62CMX8  
St/steel

# SUK61PX8

60cm "CONCERT" COOKER WITH MULTIFUNCTION  
**PYROLITIC** OVEN & GAS HOB, ST/STEEL



Photo shows legs & plinth fitted

OVEN:



10 functions Inc Circulaire element with fan



Oven capacity: gross - 79 litres, net - 72 litres

Digital electronic clock/programmer

Air cooling system

Closed door grilling

Quadruple glazed removable cooler door

Removable inner door glasses

Rotisserie

Pyrolytic cleaning

Storage compartment beneath the oven  
 St/steel feet and black plinth provided

HOB:



4 burners

Rear left: 1.75kW

Front left: Ultra Rapid 4.0kW

Rear right: 1.75kW

Front right: 1.0kW

Heavy duty cast iron pan stands

Safety valves

Automatic electronic ignition

Adaptable for LPG

Power supply required: 13 Amp fused plug

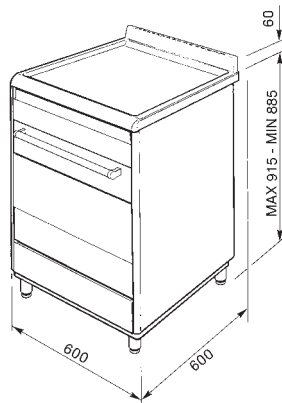

NB: Height with plinth installed is fixed at 900mm

**KIT60PX**  
 for use with:  
**SUK61PX8**

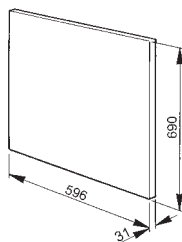

# SUK61MBL8

60cm "CONCERT" COOKER WITH MULTIFUNCTION OVEN &  
 GAS HOB, GLOSS BLACK



Photo shows legs only fitted

OVEN:

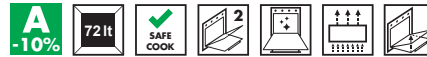

7 functions Inc Circulaire element with fan



Oven capacity: gross - 79 litres, net - 72 litres

Digital electronic clock/programmer

Air cooling system

Fully variable grill

Closed door grilling

Removable inner door glass

Vapor clean

Storage compartment beneath the oven  
 St/steel feet and black plinth provided

HOB:

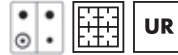

4 burners

Rear left: 1.75kW

Front left: Ultra Rapid 4.0kW

Rear right: 1.75kW

Front right: 1.0kW

Heavy duty cast iron pan stands

Safety valves

Automatic electronic ignition

Adaptable for LPG

Power supply required: 13 Amp fused plug



**SUK61MX8**  
 St/steel

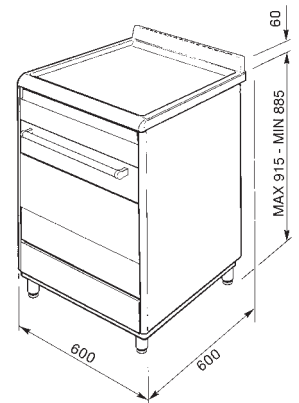

NB: Height with plinth installed is fixed at 900mm

**KIT60X**  
 for use with:  
**SUK61MBL8**  
**SUK61MX8**

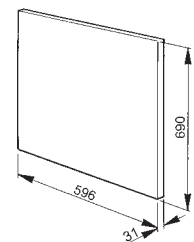

For additional information see pages 234-244

## COOKING ACCESSORIES

Smeg offers a variety of accessories for ovens, hobs and cookers, which enhance the appliances and provide added flexibility.

### GTA-6

3 LEVEL TELESCOPIC SHELF SET



Telescopic shelf set with 3 levels suitable for use with A1-7 and A3-7

### GT1T-1

1 LEVEL TELESCOPIC SHELF - TOTAL EXTRACTION



Pair of fully extractable telescopic guides suitable for use on all 60cm ovens with metal side supports. Also can be used on some cookers with metal side supports.

Also Available: GT1P-1 Telescopic shelf set with 1 partially extractable level

### PR7A2

PLATE WARMING RACK



The PR7A2 is a chrome 7-plate warming rack which fits the small oven in the A2 and SUK92 range cookers. A slightly larger 9-plate version, the PR9A3, fits the A3 Opera cooker.

### GO120

CAST IRON OPEN GRIDDLE FOR BARBECUE



The GO120 is intended to replace the Teflon plate on Opera range cookers with the electric griddle, to convert it to a barbecue.

### GC120

CAST IRON RIBBED GRIDDLE



The GC120 can replace a pan stand on Opera 120cm & 150cm dual fuel range cookers to provide a griddle plate.

### TPKX

TEPPANYAKI GRILL PLATE



Stainless steel grill plate designed for cooking Teppanyaki dishes. Suitable for all Opera cookers with gas hobs.

### TBX6090

TEPPANYAKI GRILL PLATE



The TBX6090 is a stainless steel grill plate, designed for cooking teppanyaki dishes. Suitable for Symphony and Concert cookers with cast iron pan stands.

### TPKTR

TEPPANYAKI GRILL PLATE



Stainless steel and cast iron grill plate designed for cooking teppanyaki dishes. Suitable for Victoria cookers.

### WOKGHU

CAST IRON WOK SUPPORT



The WOKGHU offers additional stability when using a wok. Suitable for most cookers and cast iron gas hobs, apart from all Classic front control 60cm gas hobs.

## GLASS SPLASHBACKS & UPSTANDS











A number of eye-catching glass splashbacks are included in the Smeg range, that are available in a wide choice of inspiring colours, finishes and sizes to enhance the diverse range of appliances.

The 8 colours available particularly complement the iconic Smeg 50's Retro appliances as well as Black, Cream and Stainless Steel products.

There are also matching 140mm high upstands available which can be fitted on the wall behind the worktop. These can be cut to size by the installer to ensure a perfect fit.

Splashbacks are a practical addition to any kitchen as they are easy to clean, with no grout lines to collect dirt or grease. They are also a very cost effective alternative to tiles that are simple and easy to install and result in a smooth and seamless finish.

The table below shows the various colours and dimensions available.

SPLASHBACKS						UPSTANDS	
DIMENSIONS	60CM W X 75CM H	75CM W X 75CM H	75CM W X 32CM H	90CM W X 75CM H	110CM W X 75CM H	2 X 100CM W X 14CM H	
GLASS COLOUR	MODEL NOS	MODEL NOS	MODEL NOS	MODEL NOS	MODEL NOS	MODEL NOS	
BLACK	 SPG6075NE	SPG7575NE	SPG7532NE	SPG9075NE	SPG110NE	UPGNE	
CREAM	 SPG6075P			SPG9075P	SPG110P	UPGP	
RED	 SPG6075R			SPG9075R		UPGR	
PASTEL BLUE	 SPG6075AZ			SPG9075AZ		UPGAZ	
LIME	 SPG6075VE			SPG9075VE		UPGVE	
SILVER	 SPG6075S	SPG7575S		SPG9075S		UPGS	
MATT WHITE	 SMG6075B	SMG7575B	SMG7532B	SMG9075B		UMGB	
MATT BLACK	 SMG6075NE	SMG7575NE	SMG7532NE	SMG9075NE		UMGNE	

### PRTX

PIZZA STONE WITH HANDLES



Refractory pizza stone with handle suitable for use with all Maxi ovens.

### PPR2

UNIVERSAL PIZZA STONE



Universal pizza stone without handles.

### PALPZ

PIZZA SHOVEL



Pizza shovel with fold away handle.

SMEG HOODS,  
FUNCTIONAL DESIGN



Hoods play an important role in the kitchen, both aesthetic and functional. Designed to offer the best combination of styling and functionality, Smeg hoods reflect the elegance and style of the other kitchen appliances with which they are installed.

## VERSATILE RANGE

### Range at a glance



CHIMNEY



ISLAND



INTEGRATED



DOWNDRAFT

Smeg hoods are both reliable and functional products, and they are available in a variety of finishes and designs to suit any kitchen. The range includes wall, island, and integrated hoods and new this year is a downdraft extractor, more details of which can be found on page 140.

### Precise Control

Functional and ergonomic, Smeg hood controls are designed for quick and simple operation to regulate extraction speed and lighting to perfection. They vary from a glass panel with touch controls to electronic buttons and electro-mechanical controls styled to co-ordinate with other Smeg products.



### Ducted v Recirculation

Smeg hoods can operate in either a ducted or recirculation mode, but the best extraction performance is achieved in the ducted mode, the preferred choice wherever possible.

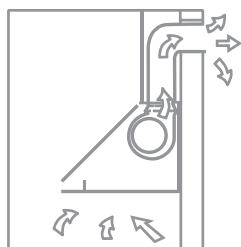

**EXTRACTOR HOOD:** extracts the cooking fumes and expels them outside, using a vent kit. The diameter of the ducting hose should match the vent outlet of the hood.

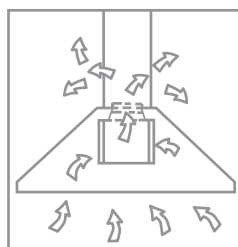

**FILTER HOOD:** extracts the cooking fumes and passes them through active charcoal filters, recirculating the cleaned air into the room.

### FEATURES AT A GLANCE

To assist in the selection of the right hood a number of symbols appear beneath each model, which act as an aid to checking and comparing the products on offer. Some examples are shown here, but details of the full range of symbols can be found at the back of the brochure.



**Electronic display** to give a visual reminder of the options selected



**Perimeter extraction** panels, very efficient and aid noise reduction



**Touch control** panel, all options selected at the touch of a fingertip



**Intensive/turbo** setting, when extra fast extraction is required



**Warning light(s)** to advise when filters need changing

### A hint of nostalgia



Bringing to mind the curved styles of retro design Smeg has introduced the KT110 hoods (in three colours, Black, Silver and Cream) and KT90 hoods (In Black and

Cream) to complement the traditional 'Victoria' range cookers. These hoods are constructed in a heat moulded material which gives the products soft curved and unbroken corners without joints, a very pleasing effect and practical to keep clean. The silver bar at the front co-ordinates with the 'Victoria' style and finishes the design of the hood.

# KT110S

110CM CHIMNEY HOOD, SILVER



1 high performance motor, 210W  
 3 speeds  
 Push button controls  
 4 aluminium grease filters  
 2 x 20W halogen lights  
 Internal re-circulation possible  
 Co-ordinates well with 'Victoria' range cooker

Speed	Extraction rate IEC 61591 (m <sup>3</sup> /h)	Noise Level IEC 60704-2-13 dB(A)
I	180	41
II	280	49
III	760	56

# KT90P

90CM CHIMNEY HOOD, CREAM

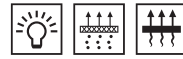

1 high performance motor, 210W  
 3 speeds  
 Push button controls  
 3 aluminium grease filters  
 2 x 20W halogen lights  
 Internal re-circulation possible  
 Co-ordinates well with 'Victoria' range cooker

Speed	Extraction rate IEC 61591 (m <sup>3</sup> /h)	Noise Level IEC 60704-2-13 dB(A)
I	180	41
II	280	49
III	760	56



KT110BL  
Black

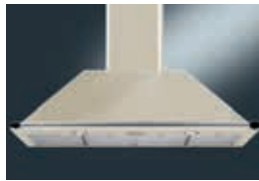

KT110P  
Cream



KT90BL  
Black

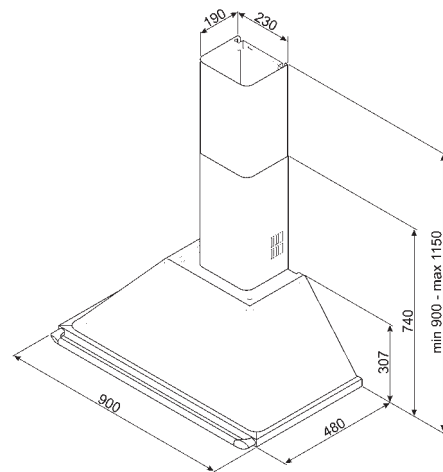
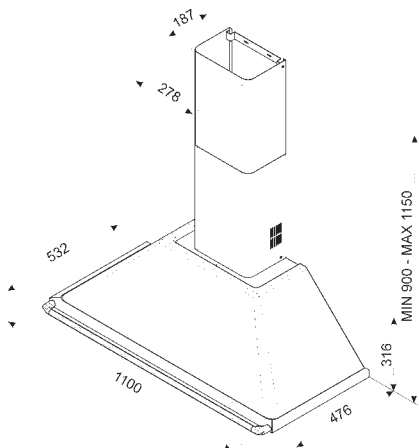



**KT110BL**

## KSE912X3

90CM CHIMNEY HOOD, ST/STEEL WITH SILVER GLASS CONTROL PANEL



1 high performance motor, 340W  
 Electronic soft touch controls  
 White digital display  
 3 speeds, plus intensive (10 min)  
 2 x 20W halogen lights with dimmer switch  
 3 st/steel grease filters (dishwasher safe)  
 Intensive speed button (10 minute timer) for each speed  
 Automatic switch off (30 minute timer) for each speed  
 Filter cleaning/replacement indicator  
 Internal re-circulation possible  
 Co-ordinates well with "Linea" style

Speed	Extraction rate IEC 61591 (m <sup>3</sup> /h)	Noise Level IEC 60704-2-13 dB(A)
I	340	54
II	540	63
III	690	69
Int	780	71



**KSE912NX3**  
 Black glass control panel

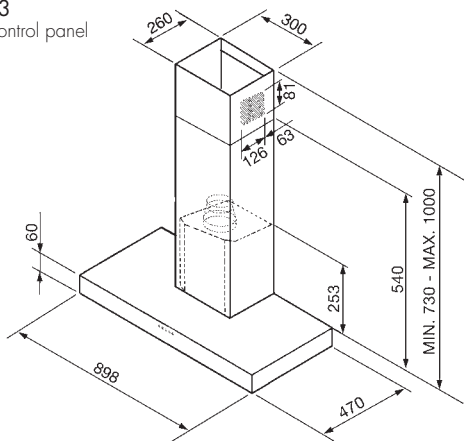

## KCVR9NE

90CM ANGLED CHIMNEY HOOD, ST/STEEL & BLACK GLASS



1 high performance motor, 450W  
 Electronic controls  
 Red digital display  
 Tilting glass panel  
**Perimeter extraction**  
 3 speeds, plus intensive (10 min)  
 2 x 20W halogen lights with dimmer switch  
 1 st/steel grease filter (dishwasher safe)  
 Intensive speed button (10 minute timer) for each speed  
 Automatic switch off (30 minute timer) for each speed  
 Filter cleaning/replacement indicator  
 Internal re-circulation possible  
 Co-ordinates well with Ceramic and Induction hobs

Speed	Extraction rate IEC 61591 (m <sup>3</sup> /h)	Noise Level IEC 60704-2-13 dB(A)
I	160	45
II	395	53
III	515	58
Int	770	71



**KCVB9B**  
 White glass panels & digital display

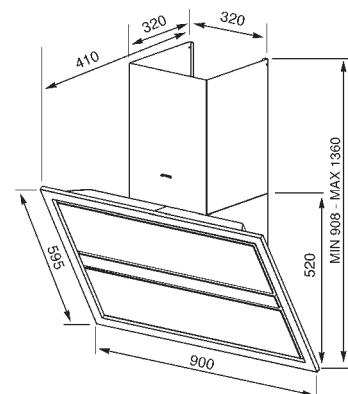

# KTS75NC

75CM "LINEA" ANGLED CHIMNEY HOOD, ST/STEEL & BLACK GLASS



- 1 high performance motor 240W
- 4 speeds
- 2 x 20W halogen lights
- Tilting glass panel
- Perimeter extraction**
- Electronic controls
- 1 st/steel anti grease filter (dishwasher safe)
- Automatic switch off (10 minute timer) for each speed
- Filter cleaning/replacement indicator
- Co-ordinates well with "Linea" style
- Internal re-circulation possible

Speed	Extraction rate IEC 61591 (m <sup>3</sup> /h)	Noise Level IEC 60704-2-13 dB(A)
I	255	45
II	325	50
III	430	57
IV	620	67



**KTS75C**  
St/steel & silver glass

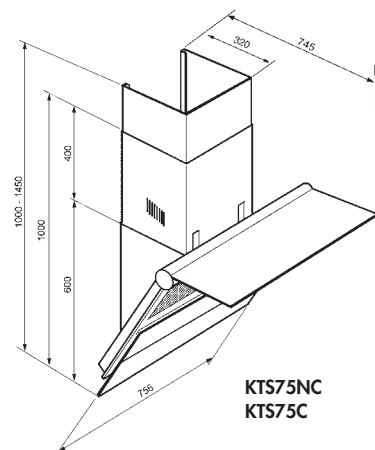

## KMN75X

75CM ANGLED CHIMNEY HOOD, ST/STEEL



1 high performance motor 340W  
 3 speeds, plus intensive (10 min)  
 2 x 20W halogen lights  
 Tilting glass panel  
 Electronic touch controls

### Perimeter extraction

Delay timer  
 Internal re-circulation possible  
 Co-ordinates well with "Newson" style, see [www.smeguk.com](http://www.smeguk.com) for further Newson products

Speed	Extraction rate IEC 61591 (m <sup>3</sup> /h)	Noise Level IEC 60704-2-13 dB(A)
I	350	47
II	450	58
III	780	66
Int	880	68

## KMN75AB

75CM ANGLED CHIMNEY HOOD, ST/STEEL AND MATT WHITE GLASS



## KMN75AN

75CM ANGLED CHIMNEY HOOD, ST/STEEL AND MATT BLACK GLASS

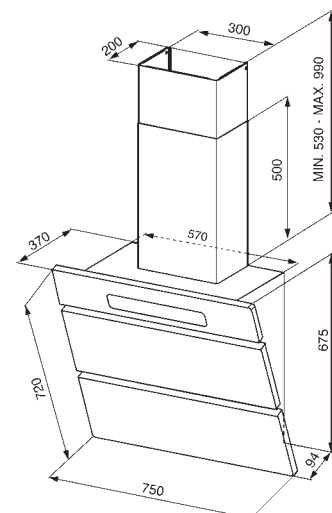



**KMN75AB**

## KD150X-2

150CM "OPERA" CHIMNEY HOOD, ST/STEEL

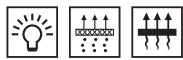

2 motors that can be selected to work together or independently  
 4 speeds for each motor  
 3 controls  
 5 st/steel grease filters (dishwasher safe)  
 4 x 20W halogen lights  
 Internal recirculation possible  
 Co-ordinates well with "Classic" style

### 1 MOTOR

Speed	Extraction rate IEC 61591 (m <sup>3</sup> /h)	Noise Level IEC 60704-2-13 dB(A)
I	50	49
II	125	53
III	250	61
IV	400	71

### 2 MOTORS

Speed	Extraction rate IEC 61591 (m <sup>3</sup> /h)	Noise Level IEC 60704-2-13 dB(A)
I	300	54
II	440	61
III	610	67
IV	770	74

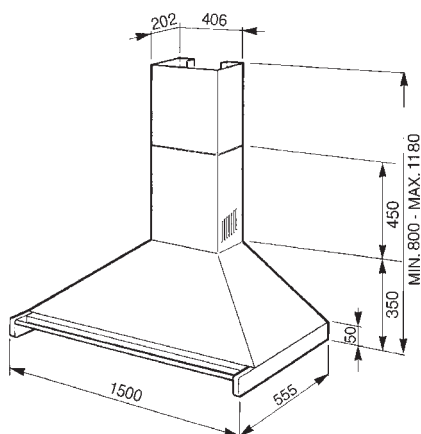

## KD120X-2

120CM "OPERA" CHIMNEY HOOD, ST/STEEL

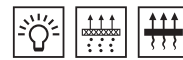

1 motor, 240W, twin fan  
 4 speeds  
 4 st/steel grease filters (dishwasher safe)  
 2 x 20W halogen lights  
 Internal recirculation possible  
 Co-ordinates well with "Classic" style

Speed	Extraction rate IEC 61591 (m <sup>3</sup> /h)	Noise Level IEC 60704-2-13 dB(A)
I	380	43
II	470	49
III	570	55
IV	770	68

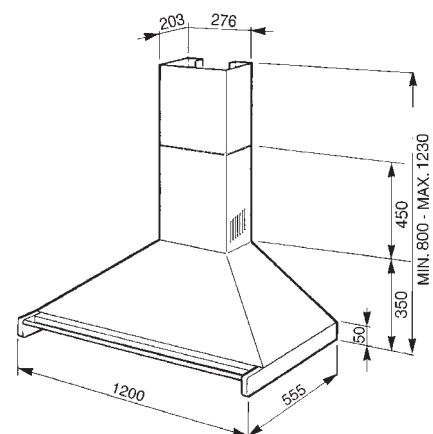

## KD100X-2

100CM "OPERA" CHIMNEY HOOD, ST/STEEL



1 motor, 240W, twin fan  
4 speeds  
3 st/steel grease filters (dishwasher safe)  
2 x 20W halogen lights  
Internal recirculation possible  
Co-ordinates well with "Classic" style

Speed	Extraction rate IEC 61591 (m <sup>3</sup> /h)	Noise Level IEC 60704-2-13 dB(A)
I	325	41
II	410	48
III	520	55
IV	765	66



**KD100N-2**  
Gloss black

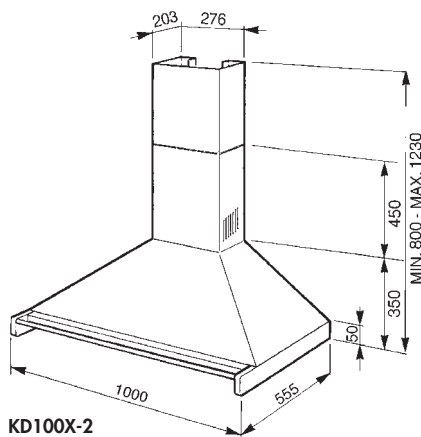

**KD100X-2**  
**KD100N-2**

## KD90N-2

90CM "OPERA" CHIMNEY HOOD, GLOSS BLACK

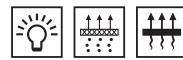

1 motor, 240W, twin fan  
4 speeds  
3 st/steel grease filters (dishwasher safe)  
2 x 20W halogen lights  
Internal recirculation possible  
Co-ordinates well with "Classic" style

Speed	Extraction rate IEC 61591 (m <sup>3</sup> /h)	Noise Level IEC 60704-2-13 dB(A)
I	260	42
II	345	48
III	460	55
IV	720	64



**KD90X-2**  
St/steel

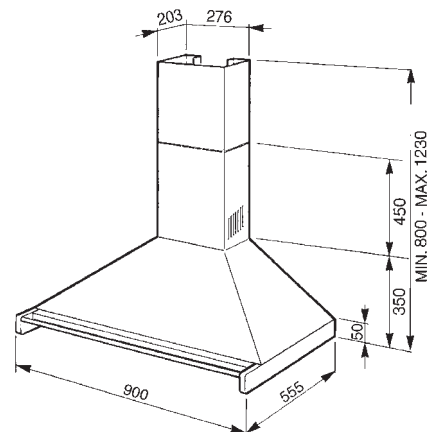

For additional information see pages 234-244

# KSE110BL

110CM "SYMPHONY" CHIMNEY HOOD, GLOSS BLACK

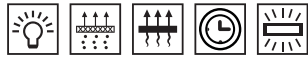
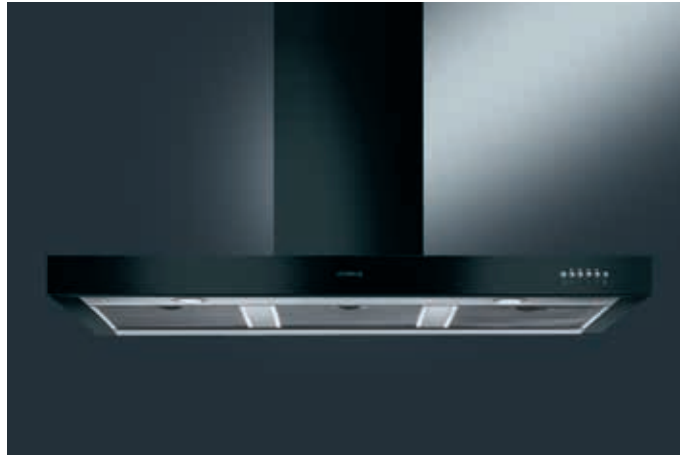

1 high performance motor  
 4 speeds  
 Electronic controls  
 3 st/steel grease filters (dishwasher safe)  
 2 x 20W halogen lights  
 Automatic switch-off (10 minute timer) for each speed  
 Filter cleaning/replacement indicator  
 Internal re-circulation possible

Speed	Extraction rate IEC 61591 (m <sup>3</sup> /h)	Noise Level IEC 60704-2-13 dB(A)
I	270	41
II	355	50
III	460	57
IV	710	67



KSE110X  
St/steel



KSE110P-9  
Cream

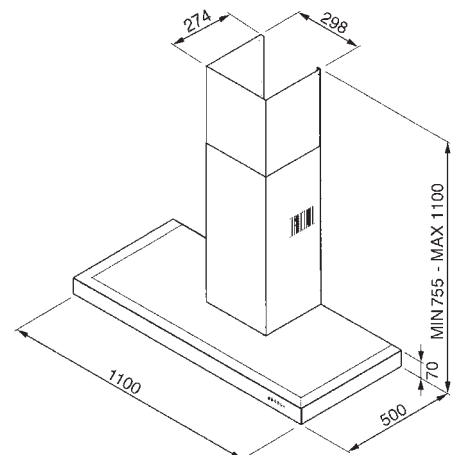

## KSED95P9

90CM CHIMNEY HOOD, GLOSS CREAM



- 1 high performance motor 280W
- 3 speeds
- 3 Aluminium grease filters (dishwasher safe)
- 2 lights
- Internal re-circulation possible

Speed	Extraction rate IEC 61591 (m <sup>3</sup> /h)	Noise Level IEC 60704-2-13 dB(A)
I	285	50
II	370	60
III	535	72



KSED95X-1  
St/steel

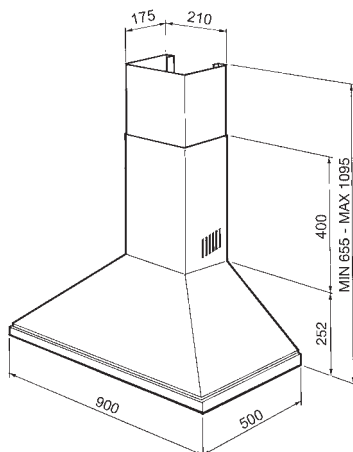

## KSED75X-1

70CM CHIMNEY HOOD, ST/STEEL

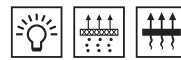

- 1 high performance motor 280W
- 3 speeds
- 2 Aluminium grease filters (dishwasher safe)
- 2 lights
- Internal re-circulation possible

Speed	Extraction rate IEC 61591 (m <sup>3</sup> /h)	Noise Level IEC 60704-2-13 dB(A)
I	270	50
II	350	60
III	530	73



KSED65X-1  
As above but 60cm wide

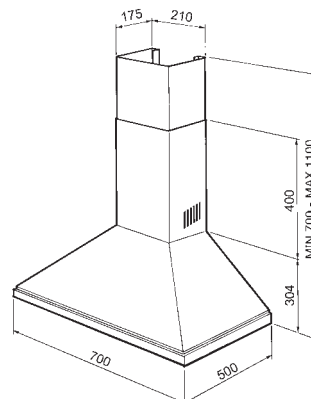

For additional information see pages 234-244



### KFV62DB

60CM CHIMNEY HOOD, WHITE GLASS & ST/STEEL



1 high performance motor, 250W  
 3 speeds  
 Push button controls  
 2 x 20W halogen lights  
 Single aluminium grease filter

Speed	Extraction rate IEC 61591 (m <sup>3</sup> /h)	Noise Level IEC 60704-2-13 dB(A)
I	255	45
II	350	55
III	650	67

### KFV62DN-2

60CM CHIMNEY HOOD, BLACK GLASS & ST/STEEL

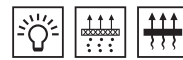

1 high performance motor, 250W  
 3 speeds  
 Push button controls  
 2 x 20W halogen lights  
 Single aluminium grease filter

Speed	Extraction rate IEC 61591 (m <sup>3</sup> /h)	Noise Level IEC 60704-2-13 dB(A)
I	255	45
II	350	55
III	650	67



KFV62D-2  
 Clear glass & st/steel

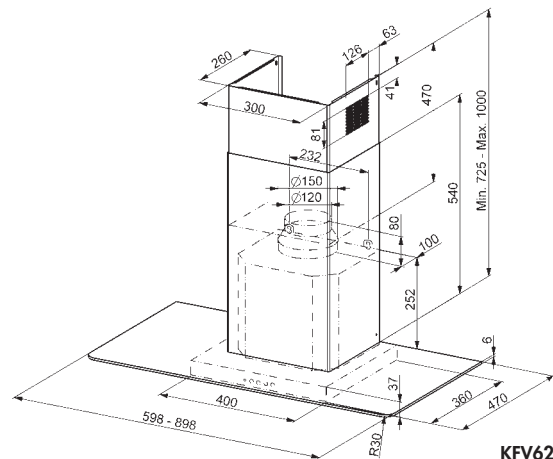

KFV62D-2  
 KFV62DN-2  
 KFV62DB

# KI120X-2

ISLAND

120CM ISLAND HOOD, ST/STEEL

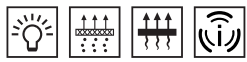

1 high performance motor, 250W  
 Electronic controls  
 3 speeds, plus intensive (10 min)  
 3 metal grease filters  
 4 x 20W halogen lights  
 Internal re-circulation possible

Speed	Extraction rate IEC 61591 (m³/h)	Noise Level IEC 60704-2-13 dB(A)
I	260	45
II	405	56
III	545	63
Int	660	68

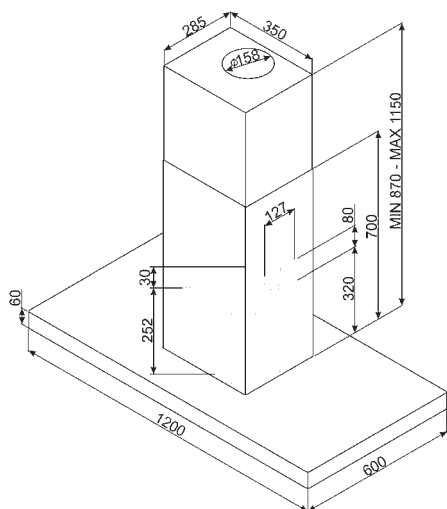

# KEIV90

ISLAND

90CM ISLAND HOOD, GLASS & ST/STEEL

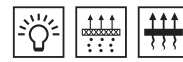

1 high performance motor, 175W  
 Electronic controls  
 3 speeds  
 2 x 20W halogen lights  
 1 metal grease filter  
 Internal re-circulation possible

Speed	Extraction rate IEC 61591 (m³/h)	Noise Level IEC 60704-2-13 dB(A)
I	185	44
II	265	53
III	365	61

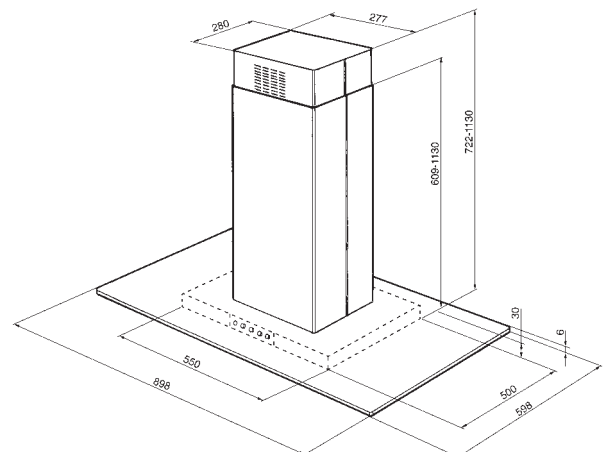

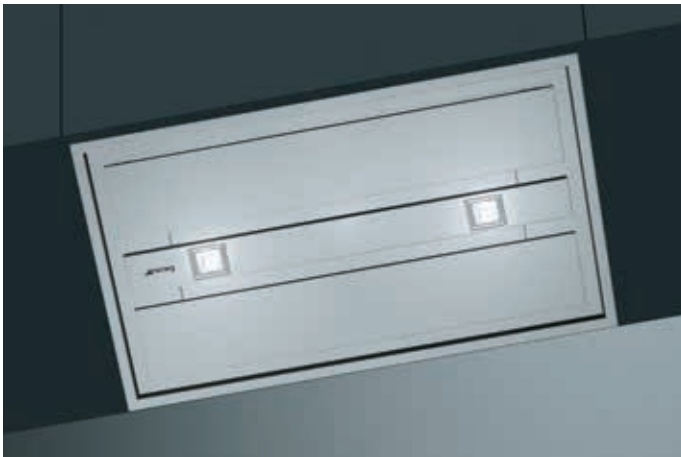

- 1 high performance motor 340W
- 3 speeds, plus intensive (10 min)
- Stainless steel filters, covered by **perimeter panels**
- Electronic controls + **remote control**
- 2 x 20W halogen lights
- Motor can be turned horizontally 360°**
- Internal re-circulation possible, but ducting to the exterior is recommended if practicable

Speed	Extraction rate IEC 61591 (m <sup>3</sup> /h)	Noise Level IEC 60704-2-13 dB(A)
I	340	47
II	560	60
III	780	67
Int	880	69

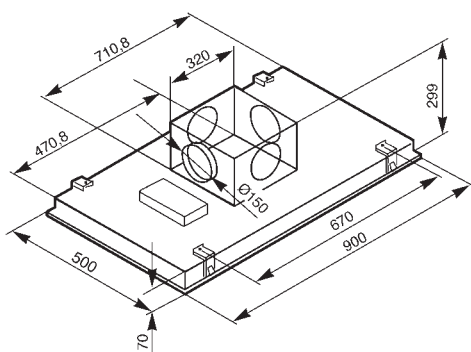

## REMOTELY CONTROLLED

The KSEG90X-1 **ceiling hood** can be positioned high over a hob adjacent to a wall or above an island unit, leaving a greater distance above the hob, which gives a perception of much more space in the kitchen.



The sleek stainless steel design responds to modern trends, is unobtrusive and understated, yet its **perimeter extraction panels** ensure powerful and efficient performance.

All the hood's functions can be easily activated by using the remote control supplied with the product.

NB: The **RCKF remote control** as an optional extra allows the smaller canopy hoods KSEG77X-1 and KSEG54X-1 found on page 142 to also be **fitted as ceiling hoods**, making them a very versatile option when considering the selection of a hood.

# KDD90VX

90CM ISLAND DOWNDRAFT HOOD, ST/STEEL AND BLACK GLASS



- 1 high performance motor, 275W
- Electronic controls
- 3 speeds, plus intensive (10 min)
- 2 aluminium grease filters
- 1 x 20W halogen light
- Internal re-circulation possible

Speed	Extraction rate IEC 61591 (m <sup>3</sup> /h)	Noise Level IEC 60704-2-13 dB(A)
I	230	39
II	420	55
III	500	61
IV	750	70
Int	660	68

For further information see pages 234-244

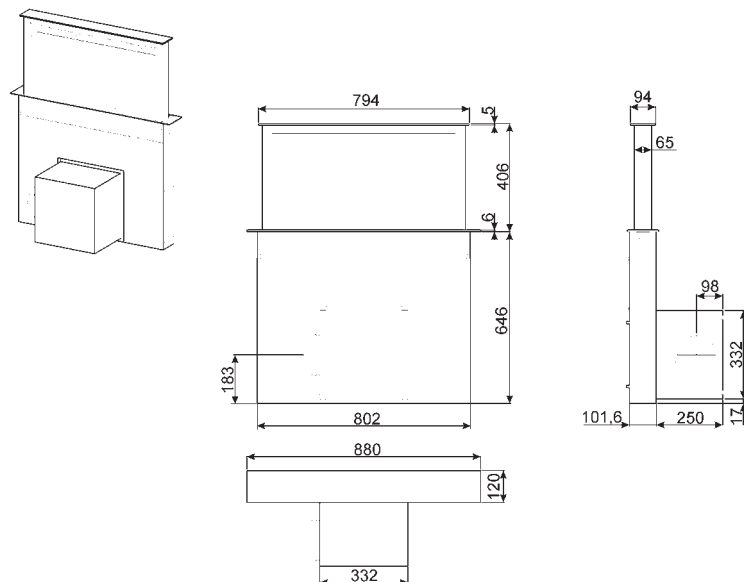



**KDD90VX**

## KSEG77X-1

77CM CANOPY HOOD, ST/STEEL



1 high performance motor 250W  
 4 Speeds, plus intensive (10 min)  
 Alluminium filters, covered by perimeter panels  
 Electronic controls  
 2 x 20W halogen lights  
**Motor can be turned vertically by 90°**  
 Internal recirculation possible

Speed	Extraction rate IEC 61591 (m³/h)	Noise Level IEC 60704-2-13 dB(A)
I	180	46
II	250	49
III	390	58
IV	530	64
Int	630	67

OPTIONAL EXTRA:

Remote control to enable use as ceiling hood      RCKF



KSEG54X-1  
 54cm canopy hood

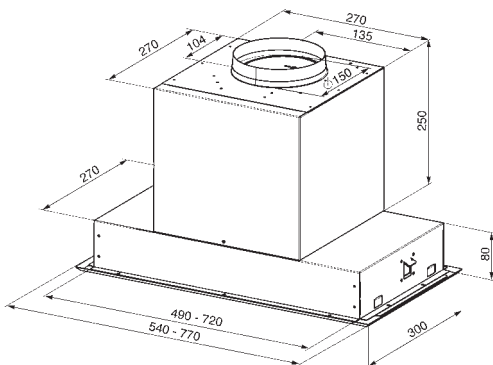

## KSET910X

90CM TELESCOPIC HOOD, ST/STEEL FRONT PANEL

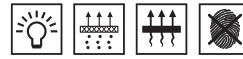

1 High performance motor, 300W  
 3 speeds  
 4 aluminium filters  
 3 x 20W halogen lights  
 Internal recirculation possible

Speed	Extraction rate IEC 61591 (m³/h)	Noise Level IEC 60704-2-13 dB(A)
I	139	27
II	195	32
III	427	48

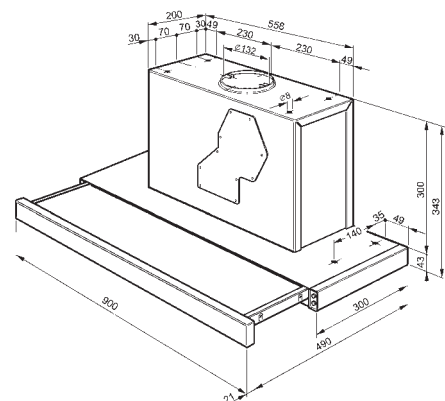

## KSET610X

60CM TELESCOPIC HOOD, ST/STEEL FRONT PANEL

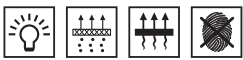

1 High performance motor, 300W  
 3 speeds  
 4 aluminium filters  
 3 x 20W halogen lights  
 Internal re-circulation possible

Speed	Extraction rate IEC 61591 (m <sup>3</sup> /h)	Noise Level IEC 60704-2-13 dB(A)
I	139	27
II	195	32
III	427	48

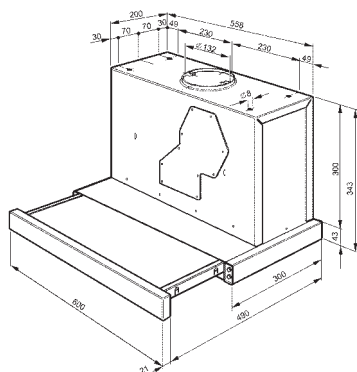

## KSEG7-1

70CM CANOPY HOOD, GREY

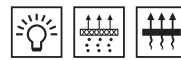

Motor speed 125W  
 3 speeds  
 1 metal grease filter  
 2 x 28W lights  
 Internal re-circulation possible

Speed	Extraction rate IEC 61591 (m <sup>3</sup> /h)	Noise Level IEC 60704-2-13 dB(A)
I	165	51
II	215	56
III	290	63

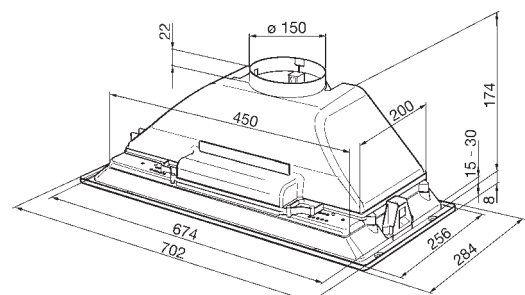

For additional information see pages 234-244

## FIRES: HEATING THE HOME WITH STYLE



Smeg has always been chosen for style as well as technology and the fires build on the Smeg look. Both **functional and beautiful**, the fires combine technology with style and have been developed to inspire ideas for expanding any living space, while at the same time offering **exciting innovation** that **complements your lifestyle**.

## DESIGNS TO FIRE IMAGINATION

Offering a choice of products that combine stylish appearance with **innovative technology**, the Smeg Fire range includes a number of exciting models, which can be easily co-ordinated with a variety of other Smeg products. All gas models are available for use with either **natural or LPG gas**. Both Linea and Classic models are available in a choice of **portrait or landscape design**.



50'S RETRO STYLE

The L30FAB incorporates the soft round curves reminiscent of 50's styling to match our FAB range, available in seven selected colours, four of which are now available in an electric version.



LINEA

The P23LIN and L23LIN incorporate the sleek and elegant lines consistent with the Linea series.

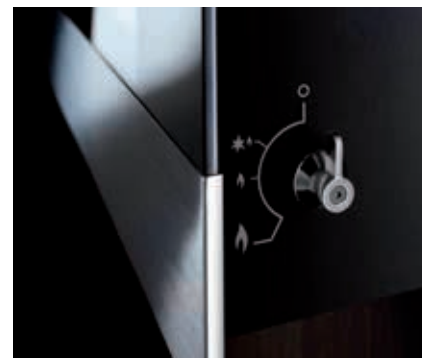

CLASSIC

The P23CL and L23CL complete the range by offering a Classic option.

### Electric fires

New to the range this year are 50's Retro Style **electric fires**, a useful alternative to gas fires. For further information see page 146.

### Interchangeable frames

Designed in order to allow more flexibility, Smeg 50's Retro Style fire frames can be easily interchanged to coordinate not only with other Smeg products, but also to complement mood or style changes throughout the home.



### INNOVATIVE GAS TECHNOLOGY

#### Environmentally and economically friendly



A flueless fire **converts 100% of the gas to heat** unlike an open or coal fire which can convert as little as 10%.



By choosing a flueless fire, it is possible to make a real contribution towards **reducing global warming and lower gas bills**. Typically, running costs for the natural gas models are approximately a third of the running cost of a conventional gas fire.

#### No chimney or flue required

Flueless fires incorporate the **latest gas fire technology** and do not require a chimney or flue to operate. Instead, the combustion gases pass through a catalytic converter system, positioned at the top of the appliance.

#### Safety

For **complete safety** and peace of mind **all Smeg fires incorporate an Oxygen Depletion Sensor (ODS)**, which detects when the oxygen levels in the room fall below a specified level. This activates the **Flame Failure Device (FFD)**, which cuts off the gas supply to the fire and renders the appliance safe.

### Choosing a location for your Gas Fire

Flueless fires are the perfect flat wall, no chimney solution to **instant warmth that simply hangs on the wall**. The technology provides a flexible design for your house or apartment, allowing you to install a fire not only in the living room, but also the diningroom, office, study and kitchen. The fires can be mounted onto almost any flat surface. There must be a minimum of 100mm clearance to the sides of the fire, 800mm to the ceiling, 500mm in front and clearance to a solid floor must be 60mm.

UNDER NO CIRCUMSTANCES CAN A GAS FIRE BE FITTED IN A BATHROOM • A GAS FIRE CAN ONLY BE FITTED IN A BEDROOM IF SPECIFIC BSI GUIDELINES ARE ADHERED TO  
• FURTHER DETAILS CAN BE FOUND ON THE SMEG WEBSITE [www.smeguk.com](http://www.smeguk.com)

## ELECTRIC VERSION OF RETRO CHIC

New to the range this year are 50's Retro Style electric fires, a useful alternative to gas fires. These are available in a choice of four colours; red, cream, black and silver, perfect for co-ordinating with other smeg appliances.

The main benefit of an electric appliance is ease of installation. Without the constraints of gas supplies and flues, electric fires simply require provision of a mains socket close to the appliance location.



Smeg electric fires have a number of features including a **unique digital display** which allows the user to see the temperature, flame and timer and it fades discreetly away when not in use. **Easy to control** with a simple remote with manual override, they have **7 heat settings** – which are selected via a **convenient thermostat** which is a real help in reducing running costs.

When the appliance is used on the **embers setting**, the fuel bed glows with flickering flames creating a realistic flame effect similar to a real fire. After the fire is switched off the embers fade progressively to give the appearance of gradual heat loss.

Another extremely useful feature of the new Smeg electric fires is the automatic switch off timer which allows you to leave it running for as little or as long as required.

L30FABECR

ELECTRIC

50's RETRO STYLE LANDSCAPE FIRE, CREAM  
ELECTRIC



L30FABEBL Black



L30FABERE Red



L30FABESI Silver

Dimensions:  
(H x W x D) 550mm x 800mm x 186mm

Fuse Rating: 13 Amp  
Heating Elements: 1800W

**LED Lighting**

Digital display timer

**Ember/ fuel bed effect**

Flame brightness (5 settings) full (5) - high (4) - medium (3) - low (2) - dim (1)

Heating (7 settings)

**Automatic switch off timer** which can be set for 10 minute intervals up to an hour and hourly up to 9 hours maximum.

**Remote control**

**Site:**

Almost any flat surface, there must be a minimum of 100mm clearance to the sides of the fire; 300mm to the ceiling, 500mm in front and clearance to a solid floor must be 300mm.

Co-ordinating refrigerators, dishwashers and laundry are also available.

FRAMES AVAILABLE IN THE FOLLOWING VERSIONS:

- Red           FRAMERE
- Black        FRAMEBL
- Cream       FRAMECR
- Silver        FRAMESI

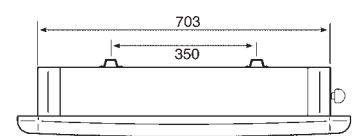
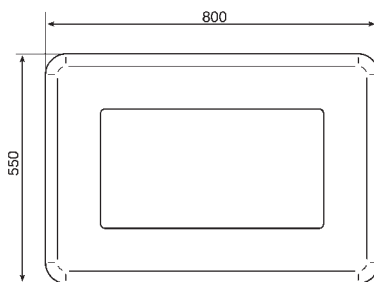
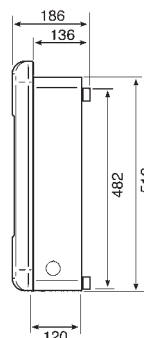

50'S RETRO STYLE  
FIRES

50's RETRO STYLE FLUELESS LANDSCAPE FIRE, RED  
 NATURAL GAS

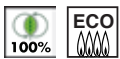

Dimensions:  
 (H x W x D) 550mm x 800mm x 186mm

Gas group:  
 Natural gas: G20 Natural Gas CAT I2H  
 LPG: G31 I3P LPG Propane

Heat Input:  
 Natural gas (Max/Min Gross): 2.6/1.5  
 LPG (Max/Min Gross): 2.2/1.5

Heat Output (Max/Min Gross):  
 Natural gas: 2.6/1.5  
 LPG: 2.2/1.5

Efficiency: 100%

Technology: Catalytic converter system

Ventilation: 100cm<sup>2</sup>

Min. Room Size: 30m<sup>3</sup>

Inlet Pressure:  
 Natural gas: 20 mbar  
 LPG: 37 mbar

Ignition: Piezo Spark

Co-ordinating refrigerators, dishwashers and laundry are also available

Installation:  
 Simply hang on the wall, no recess needed, no chimney, flue or hearth required

Site:  
 Almost any flat surface, there must be a minimum of 100mm clearance to the sides of the fire; 800mm to the ceiling, 500mm in front and clearance to a solid floor must be 60mm.

Safety Features:  
 Oxygen Depletion Sensor & Flame Failure Device

All codes shown are for natural gas models, for LPG models add a 'P' to the end of the code eg L30FABREP

FRAMES AVAILABLE IN THE FOLLOWING VERSIONS:

- |        |         |
|--------|---------|
| Red    | FRAMERE |
| Black  | FRAMEBL |
| Cream  | FRAMECR |
| Silver | FRAMESI |
| Pink   | FRAMEPI |
| Blue   | FRAMEDB |

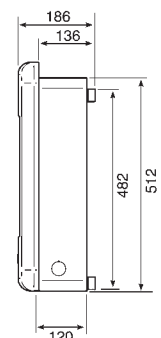
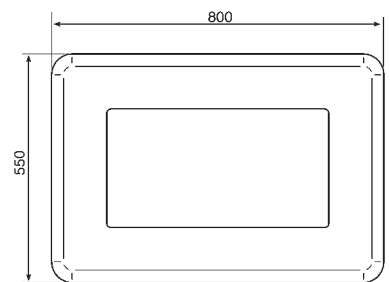
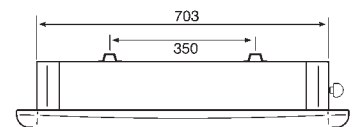



L30FABBL Black



L30FABCR Cream



L30FABDB Blue



L30FABSI Silver



L30FABPI Pink

"LINEA" FLUELESS LANDSCAPE FIRE,  
NATURAL GAS

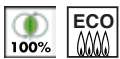

Dimensions:  
(H x W x D) 482mm x 702mm x 149mm

Gas group:  
Natural gas: G20 Natural Gas CAT 12H  
LPG: G31 I3P LPG Propane

Heat Input:  
Natural gas: (Max/Min Gross) 2.0/1.3  
LPG: (Max/Min Gross): 1.7/1.3

Heat Output:  
Natural gas: (Max/Min Gross) 2.0/1.3  
LPG: (Max/Min Gross): 1.7/1.3

Efficiency: 100%

Technology: Catalytic converter system

Ventilation: 100cm<sup>2</sup>

Min. Room Size: 23m<sup>3</sup>

Inlet Pressure:  
Natural gas: 20 mbar  
LPG: 37 mbar

Ignition: Piezo Spark

Installation:  
Simply hang on the wall, no recess needed,  
no chimney, flue or hearth required

Co-ordinating "Linea" ovens, hobs and hoods  
are also available

Site:  
Almost any flat surface, there must be a minimum  
of 100mm clearance to the sides of the fire;  
800mm to the ceiling, 500mm in front and  
clearance to a solid floor must be 60mm.

Safety Features:  
Oxygen Depletion Sensor & Flame Failure Device

AVAILABLE IN THE FOLLOWING VERSIONS:  
Landscape (Natural Gas) **L23LIN**  
Landscape (LPG) **L23LINP**

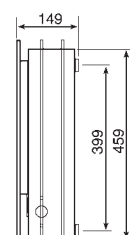
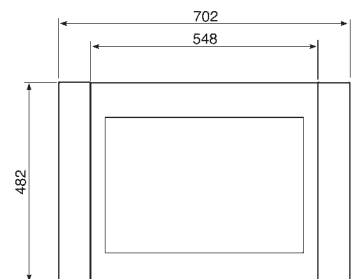
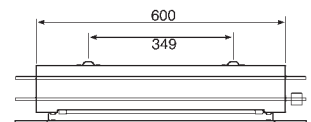

"LINEA" FLUELESS PORTRAIT FIRE,  
NATURAL GAS



Dimensions:  
(H x W x D) 590mm x 526mm x 149mm

Gas group:  
Natural gas: G20 Natural Gas CAT 12H  
LPG: G31 I3P LPG Propane

Heat Input  
Natural gas (Max/Min Gross): 2.0/1.0  
LPG: (Max/Min Gross): 1.7/1.0

Heat Output  
Natural gas (Max/Min Gross): 2.0/1.0  
LPG: (Max/Min Gross): 1.7/1.0

Efficiency: 100%

Technology: Catalytic converter system

Ventilation: 100cm<sup>2</sup>

Min. Room Size: 23m<sup>3</sup>

Inlet Pressure:  
Natural gas: 20 mbar  
LPG: 37 mbar

Ignition: Piezo Spark

Installation:  
Simply hang on the wall, no recess needed,  
no chimney, flue or hearth required

Site:  
Almost any flat surface, there must be a minimum  
of 100mm clearance to the sides of the fire;  
800mm to the ceiling, 500mm in front and  
clearance to a solid floor must be 60mm.

Safety Features:  
Oxygen Depletion Sensor & Flame Failure Device

AVAILABLE IN THE FOLLOWING VERSIONS:  
Portrait (Natural Gas) P23LIN  
Portrait (LPG) P23LINP

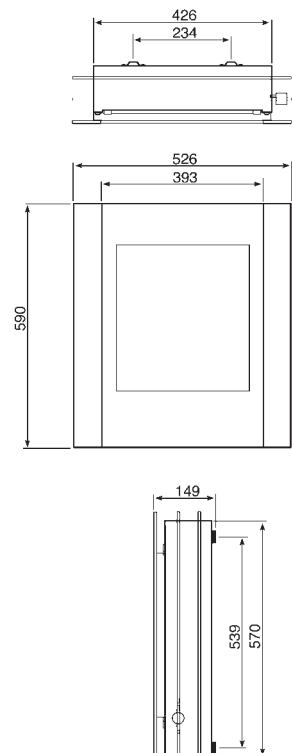

"CLASSIC" FLUELESS LANDSCAPE FIRE,  
NATURAL GAS



Dimensions:  
(H x W x D) 480mm x 702mm x 149mm

Gas group:  
Natural Gas: G20 Natural Gas CAT I2H  
LPG: G31 I3P LPG Propane

Heat Input  
Natural Gas: (Max/Min Gross): 2.0/1.3  
LPG: (Max/Min Gross): 1.7/1.3

Heat Output  
Natural Gas: (Max/Min Gross): 2.0/1.3  
LPG: (Max/Min Gross): 1.7/1.3

Efficiency: 100%

Technology: Catalytic converter system

Ventilation: 100cm<sup>2</sup>

Min. Room Size: 23m<sup>3</sup>

Inlet Pressure:  
Natural Gas: 20 mbar  
LPG: 37 mbar

Ignition: Piezo Spark

Installation:  
Simply hang on the wall, no recess needed,  
no chimney, flue or hearth required

Co-ordinating "Classic" ovens, hobs, hoods,  
dishwashers and refrigeration are also available

Site:  
Almost any flat surface, there must be a minimum  
of 100mm clearance to the sides of the fire;  
800mm to the ceiling, 500mm in front and  
clearance to a solid floor must be 60mm.

Safety Features:  
Oxygen Depletion Sensor & Flame Failure Device

AVAILABLE IN THE FOLLOWING VERSIONS:  
Landscape (Natural Gas) L23CL  
Landscape (LPG) L23CLP

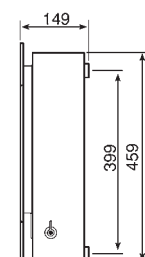
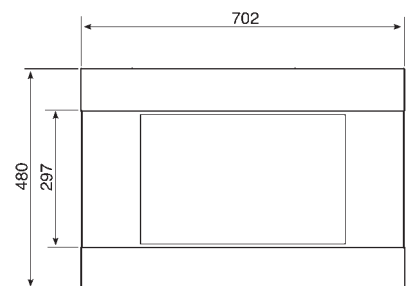
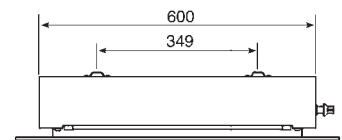

"CLASSIC" FLUELESS PORTRAIT FIRE,  
NATURAL GAS

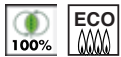

Dimensions:  
(H x W x D) 590mm x 526mm x 149mm

Gas group:  
Natural Gas: G20 Natural Gas CAT I2H  
LPG: G31 I3P LPG Propane

Heat Input  
Natural Gas: (Max/Min Gross): 2.0/1.0  
LPG: (Max/Min Gross): 1.7/1.0

Heat Output  
Natural Gas: (Max/Min Gross): 2.0/1.0  
LPG: (Max/Min Gross): 1.7/1.0

Efficiency: 100%

Technology: Catalytic converter system

Ventilation: 100cm<sup>2</sup>

Min. Room Size: 23m<sup>3</sup>

Inlet Pressure:  
Natural Gas: 20 mbar  
LPG: 37 mbar

Ignition: Piezo Spark

Installation:  
Simply hang on the wall, no recess needed,  
no chimney, flue or hearth required

Site:  
Almost any flat surface, there must be a minimum  
of 100mm clearance to the sides of the fire;  
800mm to the ceiling, 500mm in front and  
clearance to a solid floor must be 60mm.

Safety Features:  
Oxygen Depletion Sensor & Flame Failure Device

AVAILABLE IN THE FOLLOWING VERSIONS:  
Portrait (Natural Gas) P23CL  
Portrait (LPG) P23CLP

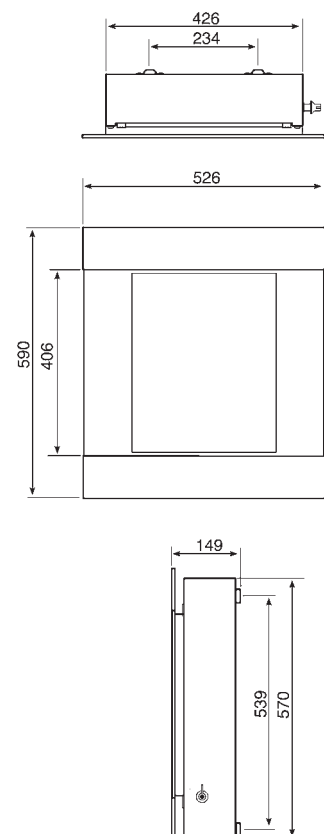

## FREESTANDING FRIDGES, EXUDING STYLE



All Smeg free standing fridges are designed to enhance the environment they inhabit. Their lines, colours and materials blend beautifully with other furniture, lending a touch of style and prestige. The wide choice of different materials and colour effects can meet all sorts of tastes and bring originality and personality to any space.

## GIVE PERSONALITY TO THE KITCHEN

Smeg fridges are more than just a commodity, freestanding refrigeration models are available in a **vast range of styles**, from contemporary stainless steel to bold retro aesthetics. They make a statement in any kitchen or perfectly complete a modern minimal design. Distinctive "Classic" style handles on some models coordinate well with many other "Classic" Smeg products.

### YOUR CHOICE OF REFRIGERATION



SINGLE WIDTH



SIDY-BY-SIDE



FRENCH DOOR



BUILT-IN

### FREE STANDING...

Free standing models can be selected to make a statement in a room, setting the style for the kitchen.

Whether a tall, short, narrow or wide model is needed, the right solution can be found in the Smeg free standing range. 50's retro models provide colour to add accents and focus to a room, and stainless steel models enhance their setting with a cool simplicity.

### ...OR BUILT-IN

All the features of built-in models remain concealed behind the kitchen furniture for a more minimalist appearance.

## FABULOUS 50'S RETRO STYLING

The iconic Smeg FAB range effortlessly combines good looks with high-performance technology. With beautiful bold finishes and soft round curves **reminiscent of 1950's retro design**, there are many colour options, from a subtle cream to a vibrant lime green. There are now six size options, from the ultra spacious FAB50 down to the petite proportions of the FAB5 minibar.



## ADVANCED TECHNOLOGY

### Features and performance



This compartment is ideal for keeping fish, meat, dairy products and other highly perishable foods fresh. The extra fresh compartment maintains a constant temperature between just above 0°C and +5°C, keeping the food fresher for longer.



**AIR PLUS** which keeps food fresher for longer. A fan in the refrigerator distributes cool air through vents to provide even cooling throughout the refrigerator, and returns the temperature to its optimum level quickly after the door has been opened.



The **Frost-free** refrigeration system ensures dry conditions by forced air circulation throughout the interior, moving between the freezer and refrigerator and preventing ice from forming on the sides. The flow of air can allow extra cool compartments in the refrigerator, useful for storing perishable items longer than usual.



In **No Frost** appliances forced air is circulated through the fridge and freezer sections separately using 2 evaporators, preventing ice forming on the sides. No Frost products have the most energy efficient frost prevention system where energy is not wasted unnecessarily, so they are more cost effective and efficient to run through the lifetime of the appliance.



The **FAST FREEZING** option is particularly useful when you want to freeze a large quantity of fresh food. Activating the fast freeze function a couple of hours before introducing the fresh food means that the freezer gets ready to work on full power, bringing the temperature right down.



The **AUTOMATIC DEFROST** system is a time saving device that works by automatically defrosting at regular intervals eradicating the need to defrost altogether.



Some refrigerators feature **LED INTERIOR LIGHTING** which illuminates the interior of the appliance. LED lighting is more energy efficient and lasts longer than traditional bulbs.



The **POWER SAVING MODE** is particularly useful in cases of prolonged absence from home such as holidays, as it allows you to disable the refrigerator and keep the freezer working which saves electricity.



Excellent insulation and special devices, specifically designed to muffle the sound generated during operation, keeps the noise to a minimum for maximum comfort in the environment.

### Respect for the Environment



All Smeg refrigerators and freezers have at least an A+ energy rating. The major drive for innovation has made it possible for some models to achieve even greater energy efficiency, with an A++ rating. Ever sensitive to the need to safeguard the environment, Smeg has been offering highly reliable models for many years that are completely free of CFCs and HFCs, the gasses responsible for the hole in the ozone layer.

### EXTENDING THE REFRIGERATION SPACE



The FR320P larder and V1205PNF freezer are designed to be fitted into a tall housing unit and can be positioned side by side in order to create a large refrigeration space that maximises food storage capabilities. This is the ideal solution for customers who require the storage space of an American side by side refrigerator but have limited kitchen space.

The Freezer is also **No Frost** which means it does not require defrosting, a very handy feature.

Freestanding models UK26PXNF3 and UK35PX3 and a number of FAB28's and CVB20's (in Cream, Red, Orange and Black) can also be positioned next to each other to create the same effect.

Over the years Smeg have accumulated solid know-how and expertise to produce innovative appliances both in terms of design and technology. The interiors are designed to allow full use of the space available, and include numerous internal storage compartments, such as chiller sections and ice dispensers.

## INGENIOUS STORAGE SOLUTIONS

Large capacity refrigerators on pages 172-174 are much in demand in today's busy world and it is important to choose the right one to match the lifestyle. Smeg offers large models in both the 'French door' and 'side-by-side' styles to suit diverse needs and all have **time-saving frost free freezers**, with no need to defrost and allowing extra cool compartments in the refrigerator section.



**Odour filter:** A specific device neutralises odours by filtering the cold air that circulates inside the refrigerator.



**Life Plus Drawers:** Kept within the controlled temperature of 0°C, perishable foods can be preserved for longer.



**Active Fresh Blue Light:** The unique lighting system increases the storage time of fruits and vegetables.



**Multizone:** This interchangeable compartment can be used as either a fridge or freezer.



The FQ55FX French door model has the convenience of the **extra wide refrigeration space** at the top, together with the features of the 4 door version,

but the freezer space is instead divided between two drawers.

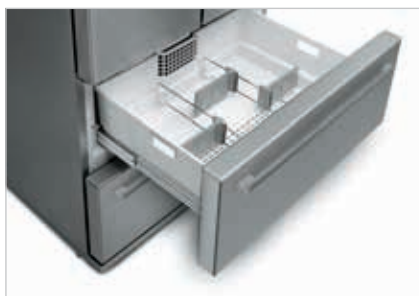

Both drawers are equipped with dividers to assist in the organisation of the food, so their contents are displayed at a glance.



The FQ60XP 4-door model is truly versatile, with its spacious and well featured refrigeration compartment at the top and the option of two freezer sections below,

or an extra refrigeration space at the lower right if less freezer space is needed.



The left hand freezer includes a **manual ice making facility**, very useful to supply ice cubes for everyday drinks or parties.



The more traditional American style side-by-side models divide the space vertically: freezer on the left, refrigerator on the right.

The refrigerator compartment offers plentiful storage options, including a **wine rack**, and even more room is found on the door.



There is ample space throughout the freezer, and it includes an **automatic ice and water dispenser** which provides ice or water at the touch of a button.

50's RETRO STYLE REFRIGERATION-FREEZER, CREAM



Gross capacity: 484 litres  
 1 compressor  
 2 adjustable thermostats  
 Noise level: 43 dB(A) RE 1 pW

REFRIGERATOR:

Fresh food capacity: 362 litres  
 2 chiller compartments  
 Automatic defrost  
 3 adjustable glass shelves  
 1 fixed glass shelf  
 2 fruit & vegetable compartments

FREEZER: \*\*\*\*

Frozen food capacity: 107 litres  
 Manual ice making facility  
 1 fast freezing compartment  
 Completely frost free

All codes shown are right hand hinged.  
 For left hand hinges add the letter S to the end of the code,  
 ie FAB50PS

NB: These models are only available from selected  
 dealers. For stockist details please see the website  
[www.smeguk.com](http://www.smeguk.com).

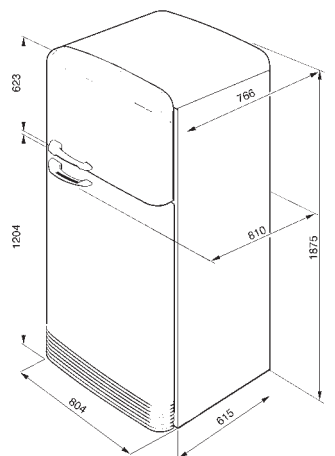

When positioning these appliances adjacent to a wall  
 or kitchen unit a gap of 200mm must be left to allow the  
 door to open.



FAB50B  
 White



FAB50X  
 Silver

For additional information see pages 234-244



**FAB50B**

# FAB32RNR

50's RETRO STYLE REFRIGERATION-FREEZER, RED



FAB32RNC Cream



FAB32RNN Black

NO FROST VERSION



Gross capacity: 328 litres  
2 adjustable thermostats  
Noise level: 41 dB(A) RE 1 pV

REFRIGERATOR:

Fresh food capacity: 229 litres  
Automatic defrost  
3 adjustable glass shelves  
1 fruit and vegetable container  
1 covered storage box  
1 chrome wine rack

FREEZER: **\*\*\*\***

Frozen food capacity: 75 litres  
2 drawers  
1 fast freezing drawer  
Ice cube tray

ONLY AVAILABLE IN THE FOLLOWING COLOURS:

Red FAB32RNR  
Cream FAB32RNC  
Black FAB32RNN

All codes shown are right hand hinged.  
For left hand hinges replace R in code with L,  
i.e FAB32LNR

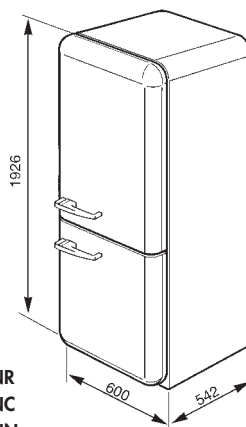

FAB32RNR  
FAB32RNC  
FAB32RNN

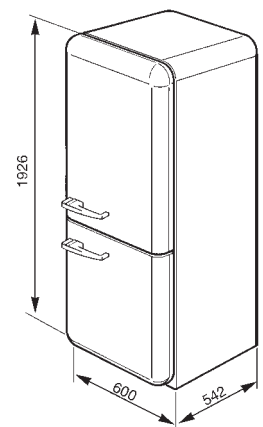

FAB32RFR  
FAB32RFC  
FAB32RFG  
FAB32RFA  
FAB32RFN  
FAB32RFL  
FAB32RFP

When positioning these appliances adjacent to a wall or kitchen unit a gap of 175mm must be left on the hinged side of the product to allow the door to open.

# FAB32RFR

50's RETRO STYLE REFRIGERATOR-FREEZER, RED



FANNED VERSION



Gross capacity: 342 litres  
 2 adjustable thermostats  
 Noise level: 41 dB(A) RE 1 pW

**REFRIGERATOR:**

Fresh food capacity: 229 litres  
 Automatic defrost  
 3 adjustable glass shelves  
 1 fruit and vegetable container  
 1 covered storage box  
 1 chrome wine rack

**FREEZER:**

Frozen food capacity: 92 litres  
 2 drawers  
 1 fast freezing drawer

All codes shown are right hand hinged.  
 For left hand hinges replace R in code with L,  
 i.e FAB32LFR



FAB32RFC Cream



FAB32RFN Black



FAB32RFA Pastel Blue



FAB32RFL Lime Green



FAB32RFG Pastel Green



FAB32RFP Pink

REFRIGERATION 50'S RETRO STYLE

# FAB30RFW

50's RETRO STYLE REFRIGERATOR-FREEZER, WHITE



White - new colour option



Gross capacity: 295 litres  
Fast cooling switch  
Noise level: 38 dB(A) RE 1 pV

#### REFRIGERATOR:

Fresh food capacity: 229 litres  
Automatic defrost  
3 adjustable glass shelves  
1 fruit and vegetable container  
1 covered storage box  
1 chrome wine rack

#### FREEZER: \*\*\*\*

Frozen food capacity: 64 litres  
1 adjustable shelf with ice cube tray

All codes shown are right hand hinged.  
For left hand hinges replace R in code with L, i.e FAB30LFO

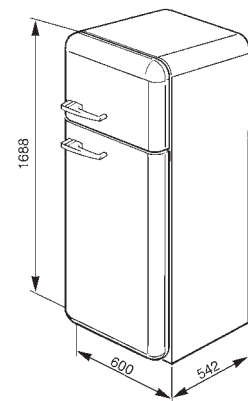

When positioning these appliances adjacent to a wall or kitchen unit a gap of 175mm must be left on the hinged side of the product to allow the door to open.



FAB30RFR Red



FAB30RFB Blue



FAB30RFN Black



FAB30RFG Green



FAB30RFA Pastel Blue



FAB30RFP Pink



FAB30RFS Silver



FAB30RFC Cream



FAB30RFO Orange



FAB30RFL Lime Green

# FAB28QP1

50's RETRO STYLE REFRIGERATOR WITH ICE COMPARTMENT, CREAM



Gross capacity: 256 litres  
Tropicalized compressor  
Climatic selector switch  
Noise level: 39 dB(A) RE 1 pW

#### REFRIGERATOR:

Fresh food capacity: 222 litres  
Automatic defrost  
3 adjustable glass shelves  
1 fruit and vegetable container  
1 chrome wine rack

#### ICE BOX: ❄️❄️❄️❄️

Frozen food capacity: 26 litres  
Ice cube tray

All codes shown are right hand hinged.  
For left hand hinges replace Q in code with Y, i.e FAB28YB1

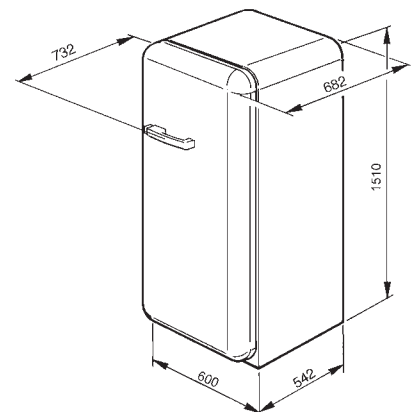

When positioning these appliances adjacent to a wall or kitchen unit a gap of 175mm must be left on the hinged side of the product to allow the door to open.



FAB28QG1 Yellow



FAB28QVE1 Lime Green



FAB28QO1 Orange



FAB28QAZ1 Pastel Blue



FAB28QRO1 Pink



FAB28QV1 Pastel Green



FAB28QR1 Red



FAB28QB1 White



FAB28QBL1 Blue



FAB28QX1 Silver



FAB28QNE1 Black

FAB28QCS1

SPECIAL EDITION

50's RETRO STYLE REFRIGERATOR WITH ICE COMPARTMENT,  
COLOUR STRIPE



Gross capacity: 256 litres  
Tropicalized compressor  
Climatic selector switch  
Noise level: 40 dB(A) RE 1 pW

REFRIGERATOR:

Fresh food capacity: 222 litres  
Automatic defrost  
3 adjustable glass shelves  
1 fruit and vegetable container  
1 chrome wine rack

ICE BOX: ❄️❄️❄️❄️

Frozen food capacity: 26 litres  
Ice cube tray



FAB28QUJ1  
Union Jack

FAB28RDB

LIMITED EDITION

50's RETRO STYLE REFRIGERATOR WITH ICE COMPARTMENT,  
DENIM



MODELS PICTURED ARE RIGHT HAND HINGED.

ALSO AVAILABLE WITH LEFT HAND HINGES:-

Colour stripe      FAB28YCS1  
Union Jack        FAB28YUJ1

NB: The fabric of the Denim fridge, has been treated with PLASMA, a nano-technology, which protects the surface of the fridge from splashes of water, oil, milk and fruit juices. The Denim FAB is **only available right hand hinged**.

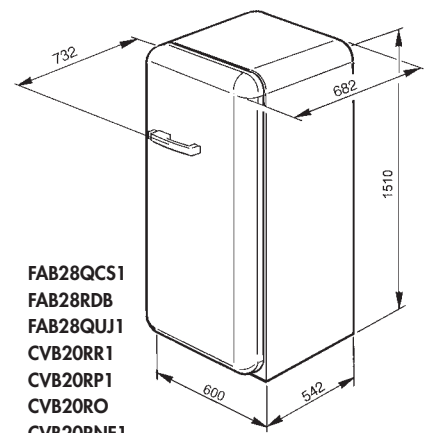

- FAB28QCS1
- FAB28RDB
- FAB28QUJ1
- CVB20RR1
- CVB20RP1
- CVB20RO
- CVB20RNE1

When positioning these appliances adjacent to a wall or kitchen unit a gap of 175mm must be left on the hinged side of the product to allow the door to open.

# CVB20RR1

50's RETRO STYLE UPRIGHT FREEZER, RED



Gross Capacity: 197 litres  
Acoustic alarm  
Noise level: 42 dB(A) RE 1 pW

FREEZER: **\*\*\*\***  
Frozen food capacity: 170 litres  
Fast freezing button  
2 ice cube trays  
3 transparent drawers  
2 transparent flaps

All codes shown are right hand hinged.  
Also available with left hand hinges (L) i.e CVB20LR

Whereas every effort is made to ensure that colours are matched, those of two adjacent appliances may seem to alter under different lighting conditions. Products dimensions should be checked when pairing a freezer with an existing fridge.



CVB20RP1  
Cream

CVB20RNE1  
Black

CVB20RO  
Orange

For additional information see pages 234-244

## FAB10RR

50's RETRO STYLE REFRIGERATOR WITH ICE  
COMPARTMENT, RED



## FAB10RUJ SPECIAL EDITION

50's RETRO STYLE REFRIGERATOR WITH ICE  
COMPARTMENT, UNION JACK



Gross capacity: 120 litres  
Climatic selector switch  
Noise level: 37 dB(A) RE 1 pV

REFRIGERATOR:  
Fresh food capacity: 107 litres  
Automatic defrost  
Adjustable thermostat  
2 adjustable glass shelves  
1 fruit and vegetable drawer

ICE BOX: ❄️❄️❄️❄️  
Frozen food capacity: 13 litres  
Ice cube tray

All codes shown are right hand hinged.  
For left hand hinges replace R in code with L,  
i.e FAB10LP



FAB10RP  
Cream

FAB10RNE  
Black

FAB10RO  
Orange

FAB10RB  
White

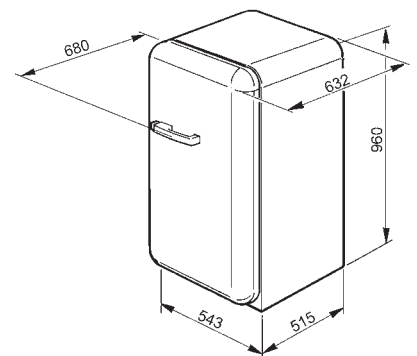

When positioning these appliances adjacent to a wall or kitchen unit a gap of 175mm must be left on the hinged side of the product to allow the door to open.

FAB10HRP

HOME BAR

50'S RETRO STYLE HOME BAR REFRIGERATOR,  
CREAM



Gross capacity: 135 litres  
Climatic selector switch  
Noise level: 37 dB (A) RE 1 pV

REFRIGERATOR:  
Fresh food capacity: 130 litres  
Automatic defrost  
Adjustable thermostat  
2 adjustable glass shelves  
1 chrome wine rack  
Bottle and can separators

All codes shown are right hand hinged.  
For left hand hinges replace R in code with L,  
i.e FAB10HLP



FAB10HRR  
Red

FAB10HRNE  
Black

FAB10HRB  
White

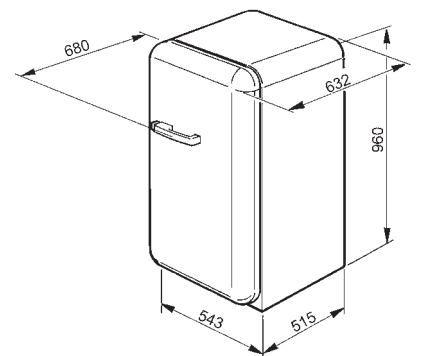

When positioning these appliances adjacent to a wall or kitchen unit a gap of 175mm must be left on the hinged side of the product to allow the door to open.

50's RETRO STYLE MINI BAR REFRIGERATOR,  
BLACK



Gross capacity: 42 litres  
Net capacity: 40 litres

Absorption cooling = ultra low noise level  
LED internal light  
2 adjustable shelves  
Door storage: 1 balcony shelf, 1 bottle shelf  
Ice cube tray

All codes shown are right hand hinged. For left hand hinges replace R in code with L, ie FAB5LNE

## ABSORPTION COOLING

Mini bars use an **absorption cooling** system in place of the usual compressors which are found in other Smeg refrigeration models. The great advantage of this system is that it has an **extremely low operational noise level**, in fact the FAB5 running at 29 dB (A) RE 1 pW is hardly heard at all. Mini bars have been used traditionally in hotel bedrooms, but are now available for home use too.

The energy efficiency of absorption models is measured in a different way from standard refrigeration, and as a comparison an absorption model rated C is the equivalent of a compressor model rated A+++ . The FAB5 is rated E, the equivalent of a compressor model rated A+.

The FAB5 may be the tiniest model in the Smeg 50's Retro range, but there is still plenty of space for a selection of drinks and snacks, plus a tray to store ice cubes conveniently at hand.



FAB5RO  
Orange

FAB5RP  
Cream

FAB5RR  
Red

FAB5RUJ  
Union Jack

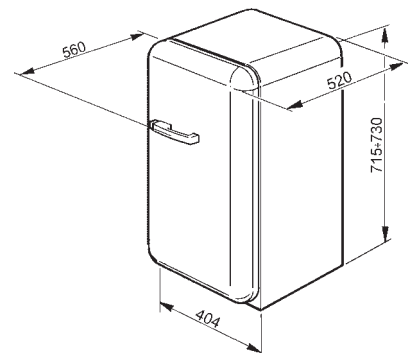



**FAB5RNE**

# FQ60XP

'FRENCH DOOR' REFRIGERATOR-FREEZER WITH 4 FINGER-FRIENDLY ST/STEEL DOORS AND SILVER SIDES



Gross capacity: 610 litres  
Noise level: 43 dB(A) re 1 pW

**MultiZone compartment, can be used as fridge or freezer**  
Soft touch indicator panel  
Power saving mode

**REFRIGERATOR:**  
Fresh food capacity: 385 litres  
Possibility of further 77 litres using MultiZone as refrigerator  
**Extra wide storage** - internal width 80cm  
**2 Life Plus 0°C drawers**  
**LED interior lighting**  
Automatic defrost  
3 glass shelves  
2 fruit and vegetable drawers with **Active Blue Light**  
Comprehensive door storage

**MULTIZONE:**  
**Can be used as either refrigerator or freezer**  
Capacity: 77 litres  
1 open storage section with shelf  
2 drawers

**FREEZER:**  
Capacity: 78 litres  
Possibility of further 77 litres using MultiZone as freezer  
Internal manual icemaker  
3 drawers  
Fast freeze function  
**Completely No Frost**

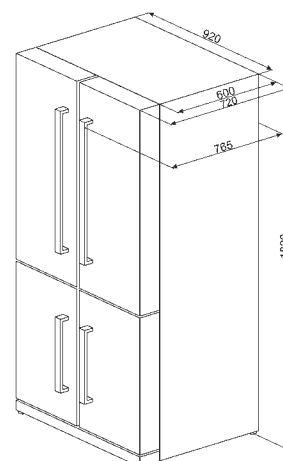

# FQ55FX

'FRENCH DOOR' REFRIGERATOR-FREEZER WITH 2 FINGER-FRIENDLY ST/STEEL DOORS, 2 DRAWERS, AND SILVER SIDES



Gross capacity: 600 litres  
Noise level: 40 dB(A) re 1 pW

**REFRIGERATOR:**

- Fresh food capacity: 396 litres
- Extra wide storage - internal width 73cm
- 2 Life Plus 0°C drawers
- LED interior lighting
- Automatic defrost
- 3 glass shelves
- 2 fruit and vegetable drawers with Active Blue Light
- Comprehensive door storage

**FREEZER:**

- Capacity: 154 litres
- 2 full width drawers, fitted with dividers
- Inner drawers removable
- 2 ice cube trays
- Fast freeze function
- Completely No Frost

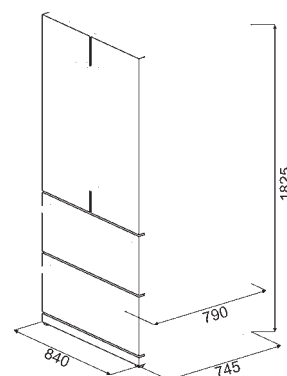

REFRIGERATION

## FA55PCIL3

AMERICAN STYLE SIDE BY SIDE REFRIGERATOR-FREEZER,  
FULLY CLAD IN ST/STEEL



## FA55XBIL3

AMERICAN STYLE SIDE BY SIDE REFRIGERATOR-FREEZER,  
ST/STEEL DOORS AND GRAPHITE SIDES



FOR BOTH MODELS ON THIS PAGE:

Gross capacity: 600 litres  
Noise level: 44 dB(A) RE 1 pVW

LCD display and soft touch control panel  
Ice and water dispenser  
Power saving mode  
Child lock function

REFRIGERATOR:  
Fresh food capacity: 358 litres  
"Extra Fresh" zone with soft-touch control  
2 drawers with humidity control  
Chrome wine rack  
4 temperature sensors

FREEZER **\*\*\*\***  
Frozen food capacity: 173 litres  
Completely frost free  
Fast freeze  
2 drawers  
4 glass shelves  
4 temperature sensors

Model FA55XBIL3 can be built-in

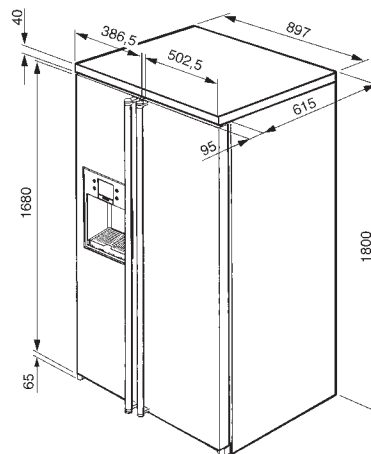

FA55PCIL3

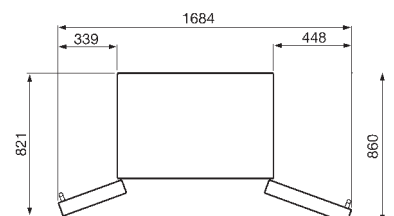
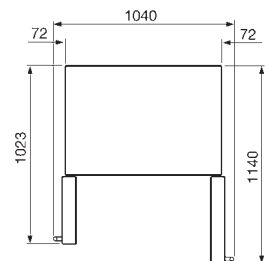

# FC34XPNF

REFRIGERATOR FREEZER WITH ST/STEEL EFFECT DOORS



Gross capacity: 344 litres  
 Integrated handle  
 Noise level: 45 dB (A) RE 1 pW

REFRIGERATOR:  
 Fresh food capacity: 228 litres  
 Automatic defrost  
 3 adjustable glass shelves  
 1 glass fruit and vegetable cover  
 2 fruit and vegetable drawers

FREEZER:  
 Frozen food capacity: 90 litres  
 3 drawers  
 Completely No frost

This design without handles co-ordinates with all aesthetics.

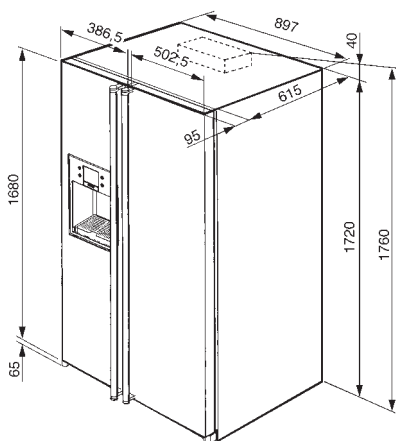

FA55XBIL3

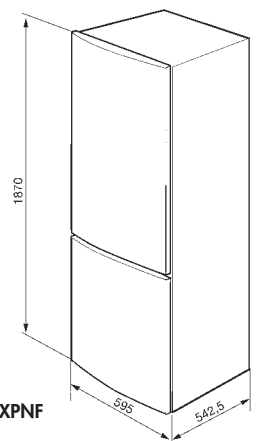

FC34XPNF

REFRIGERATION



**UK26PXNF3**  
**UK35PX3**

## UK26PXNF3

FREEZER WITH ST/STEEL EFFECT DOOR



## UK35PX3

UPRIGHT LARDER WITH ST/STEEL EFFECT DOOR



Gross capacity: 265 litres  
Noise level: 44 dB (A) RE 1 pW

### FREEZER:

Frozen food capacity: 251 litres  
5 drawers  
2 shelves with flaps

**Fast freeze function**  
**Completely No Frost**

Co-ordinates with UK35PX3

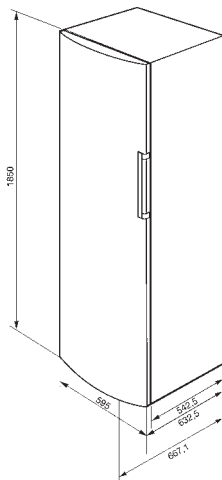

Gross capacity: 353 litres  
Noise level: 40 dB (A) RE 1 pW

### REFRIGERATOR:

Fresh food capacity: 349 litres  
Automatic defrost  
4 adjustable glass shelves  
1 glass fruit and vegetable cover  
2 fruit and vegetable containers  
Comprehensive door storage

Co-ordinates with UK26PXNF3

### OPTIONAL EXTRA:

Linking kit **REFLK**

Holds UK26PXNF3 and UK35PX3 in place  
when positioned next to each other.

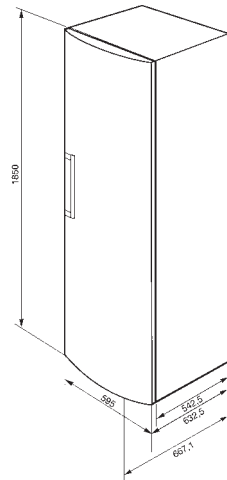

## CR330AP

IN COLUMN COMBINED REFRIGERATOR-FREEZER



Gross capacity: 311 litres  
Noise level: 39 dB(a) re 1 pW

### REFRIGERATOR:

Fresh food capacity: 213 litres  
Automatic defrost  
4 adjustable glass shelves  
Glass fruit and vegetable cover  
2 fruit/vegetable containers  
Comprehensive door storage

### FREEZER: \*\*\*\*

Frozen food capacity: 52 litres  
3 compartments

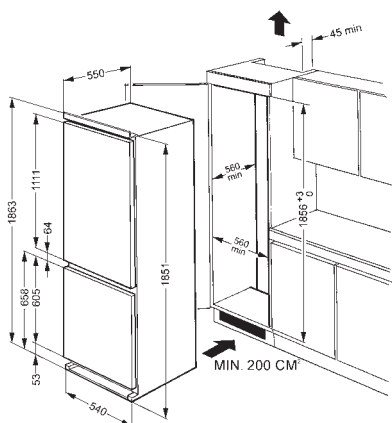

## CR325PNFZ

IN COLUMN COMBINED REFRIGERATOR-FREEZER

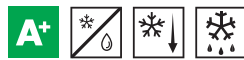

Gross capacity: 282 litres  
Electronic control panel  
Noise level: 38 dB(A)RE 1 pW

### REFRIGERATOR:

Fresh food capacity: 201 litres  
Automatic defrost  
3 adjustable glass shelves  
0°C compartment  
1 glass fruit & vegetable cover  
2 fruit and vegetable drawers  
Comprehensive door storage

### FREEZER: \*\*\*\*

Frozen food capacity: 63 litres  
3 drawers  
Fast freezing compartment  
Ice cube tray  
Completely frost free

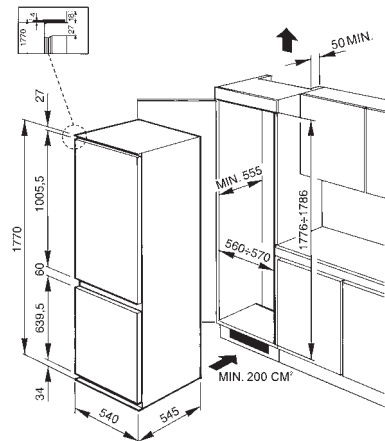

## CB30PFNF

IN COLUMN COMBINED REFRIGERATOR-FREEZER WITH ICE MAKING FACILITY



Gross capacity: 262 litres  
LED display and electronic control  
Noise level: 35 dB(a) re 1 pW

### REFRIGERATOR:

Fresh food capacity: 188 litres  
Extra Fresh zone  
4 transparent glass shelves  
Fruit and vegetable container

### FREEZER: \*\*\*\*

Frozen food capacity: 60 litres  
Fast freeze compartment  
3 transparent drawers  
Manual ice making facility  
Completely frost free

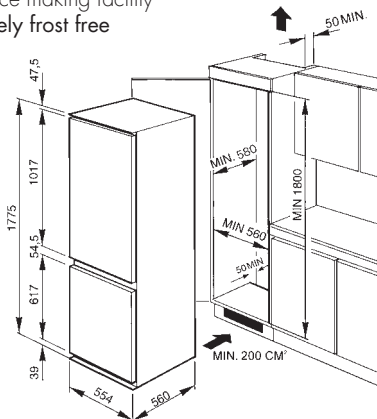

## FR310P

IN COLUMN LARDER REFRIGERATOR WITH FREEZER COMPARTMENT



Gross capacity: 297 litres  
Electronic thermostat with LED light  
Noise level: 32 dB(a) re 1 pW

### REFRIGERATOR:

Fresh food capacity: 264 litres  
Automatic defrost  
4 adjustable glass shelves  
1 glass fruit and vegetable cover  
2 fruit and vegetable containers

### FREEZER: \*\*\*\*

Frozen food capacity: 32 litres  
Ice-cube tray

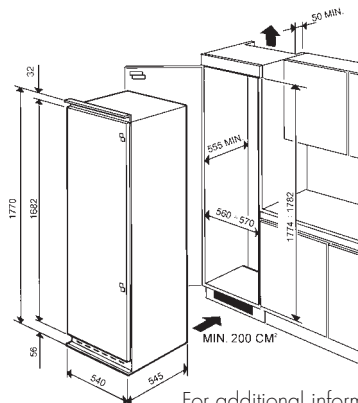

For additional information see pages 234-244

## VI205PNF

IN COLUMN FREEZER



Gross capacity: 190 litres  
LED panel with electronic control  
Noise level: 42 dB(A) RE 1 pW

FREEZER: **\*\*\***  
Frozen food capacity: 190 litres  
Fast freezing function  
5 transparent drawers  
2 shelves with transparent flaps  
Acoustic alarm  
Completely No frost

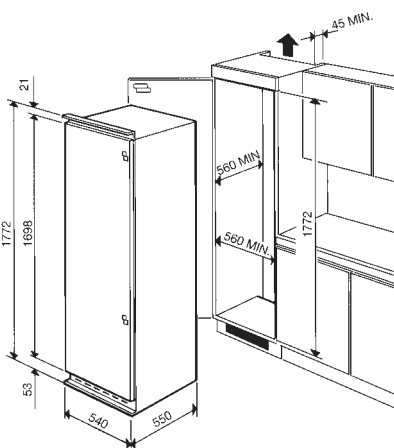

## FR320P

IN COLUMN LARDER REFRIGERATOR



Gross capacity: 320 litres  
Noise level: 40 dB(A) RE 1 pW

REFRIGERATOR:  
Fresh food capacity: 303 litres  
Automatic defrost  
1 chrome wine rack  
6 adjustable glass shelves  
1 glass fruit and vegetable cover  
3 fruit and vegetable containers  
Comprehensive door storage

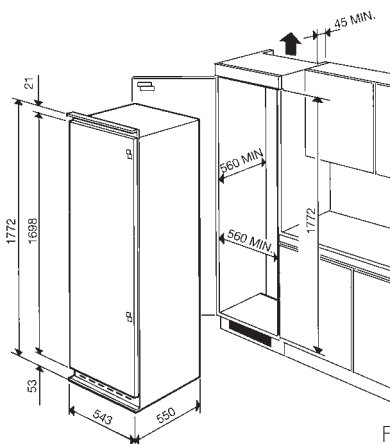



**VI205PNF  
FR320P**

## FR2052P1

IN COLUMN REFRIGERATOR WITH ICE BOX



Gross capacity: 207 litres  
Electronic thermostat  
Noise level: 36 dB (A) re 1 pW

### REFRIGERATOR:

Fresh food capacity: 184 litres  
Automatic defrost  
3 adjustable glass shelves  
1 fixed glass shelf  
1 fruit and vegetable drawer  
Comprehensive door storage

### ICE BOX: ❄️❄️❄️❄️

Frozen food capacity: 18 litres  
Ice cube tray

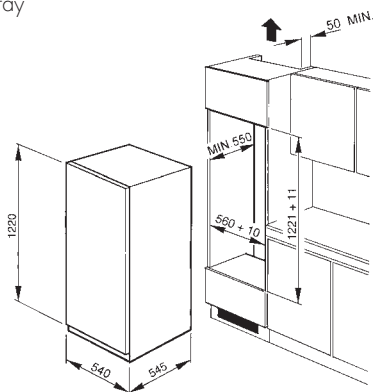

## FR2202P1

IN COLUMN LARDER REFRIGERATOR



Gross capacity: 222 litres  
Electronic thermostat  
Noise level: 36 dB (A) re 1 pW

### REFRIGERATOR:

Fresh food capacity: 219 litres  
Automatic defrost  
4 adjustable glass shelves  
1 fixed glass shelf  
1 fruit and vegetable drawer  
Comprehensive door storage

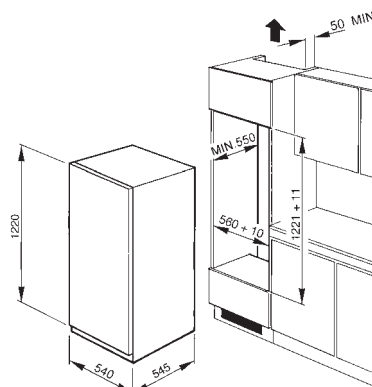

# VR105AP1

IN COLUMN FREEZER



Gross capacity: 71 litres  
Noise level: 39 dB (A) RE 1 pW

FREEZER:  
Frozen food capacity: 53 litres  
2 storage compartments  
1 drawer

Possible combination with FR2052P1 or FR2202P1

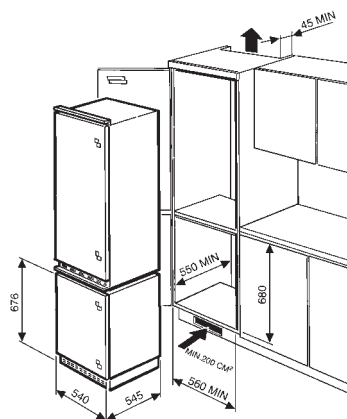

SMEG DISHWASHERS, STYLISH, INNOVATIVE AND EFFICIENT



Designed to produce optimum wash results with minimum use of energy and water, dishwashers are offered in a variety of types to suit any installation, and many of the styles can be co-ordinated with other Smeg appliances.

## COMPREHENSIVE RANGE

The dishwasher is an essential component of the modern kitchen, but before deciding on a particular model it is worth considering the merits of a freestanding model, which will be more obviously visible in the room, or the clean lines of an integrated model, which will be incorporated as part of the kitchen design.

### Freestanding

A freestanding dishwasher can be a good choice in a kitchen or utility room where the current style is not necessarily permanent, as its position can be changed very simply, without the need of installation work.



ST/STEEL

Stainless steel models can be chosen with hidden controls or with a visible control panel, in a 60cm or 45cm width. Some are styled to co-ordinate with other Smeg appliances.



BLACK & WHITE

Smart gloss black options can be selected in a 60cm or 45cm width, whilst white options are available in a 60cm width. A freestanding model is available to suit any kitchen style or size, and there are different dishwasher specifications to match most requirements and budgets.



50'S RETRO STYLE

**50's retro design** in a choice of bright bold shades and soft pastel tones meets a high quality 60cm dishwasher to bring a touch of colour to the kitchen. The look is completed by the addition of colour coordinating racks and cutlery basket.

### Built in

A wide range of built-in dishwashers encompasses three styles, some in 60cm and 45cm widths. The sleek lines of integrated dishwashers allow the appliance to blend into both traditional and modern kitchen designs with ease.



FULLY INTEGRATED

If the style of the kitchen dictates that the appliances should be completely hidden to present a minimal effect, then the **fully integrated option** is ideal.



ST/STEEL DOOR

Built-in models with a **finger-friendly stainless steel door** and a Classic style handle may be selected in 60cm or 45cm versions to co-ordinate with other Smeg Classic appliances.



50'S RETRO

The 50's retro style built-in dishwasher, with **colour co-ordinating cutlery basket and racks**, makes a bold statement in the kitchen.

## NEW DESIGN 3RD BASKET: FLEXIDUO



Smeg have completely redesigned the **3rd cutlery basket** to create a totally new solution: the **Smeg FlexiDuo** which allows you to arrange cutlery or small cups, ladles, or bulky utensils however you like: it consists of two separate and moveable sections, which can be adjusted individually depending on the dishes placed in the basket below, or even removed entirely depending on your loading needs. FlexiDuo baskets are featured on all 13 place setting models.



## THREE LOADING LEVELS TO OPTIMISE SPACE



The 13 place setting configuration offers a **high load flexibility** and **greater performance**.



The interiors of these models have been re-designed to feature the new FlexiDuo baskets at the top, allowing a greater flexibility when loading the dishwasher.

The three loading levels optimizes space within the dishwasher so once loaded an even larger amount can be washed during one cycle.

The baskets below the FlexiDuo baskets can be automatically adjusted on 3 levels, even when the basket is loaded, to allow plates of up to 30cm diameter to be placed below, and the lower basket includes a number of adjustable sections.

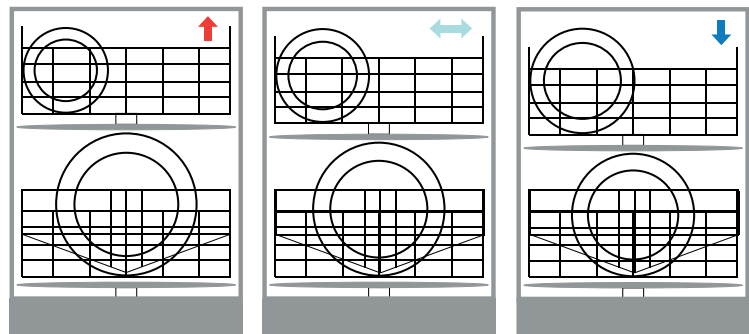

12 place settings models are very simple to operate and offer a double A class performance for a modest outlay. The two baskets hold a full 12 place setting load and can still accommodate 30cm diameter plates when the top basket is manually adjusted to its upper level.

60cm Smeg dishwashers are available in a **choice of 12 or 13 place settings**, with a greater freedom of placement in the dishwasher, anticipating the needs and expectations of modern consumers.

## 10 PLACE SETTINGS: 45CM SPACE SAVING SOLUTION



The range also includes a number of 45cm dishwashers with 10 place settings, a great solution for singles or small kitchens. The 45cm dishwashers have been renewed by improving performance and functionality.

The shuttle system has been replaced by the patented Swing Wash System which allows better coverage within the tank improving the dishwashers washing performance. In addition to the options previously available on the 45cm models, the range has been upgraded with other options already available on 60cm models such as: FlexiZone, FlexiTabs, Delay timer up to 24hrs (previously only up to 9hrs), Hyclean and Quick Time.

With a capacity of just 10 place settings, these machines allow smaller daily wash cycles to be run efficiently in comparison with a 60cm model, where the same load size would leave wasted space.

## 'PRESS AND RELEASE' DOOR FOR HANDLE-LESS KITCHENS



The DI6013NH1 features a patented '**press and release**' door design which is a perfect solution for handle-less kitchen units as **no handle is needed**.

By simply pressing the dishwasher door at the top in the centre, it makes a slight contact with the appliance and opens using Smeg's **patented sensor technology**. For safety reasons, the door locks automatically when the machine is in use to avoid it being opened inadvertently.

## ACTIVE LIGHT



A number of built-in models include **ActiveLight**, a red LED light which projects a red spot onto the floor beneath the dishwasher door when the appliance is in use. This makes it immediately obvious that the appliance is running, just by glancing at the light on the floor, so that the door is not accidentally opened before the wash phase has finished.

## FUNCTIONAL SOLUTIONS

### Front adjustable levelling feet



The majority of built-in models include **rear levelling feet** that can be **easily adjusted from the front**, allowing adjustment of the height of the machine when already integrated into the kitchen furniture. Levelling the appliance is essential for ensuring correct operation of the dishwasher, and with this innovative yet simple feature the need to

attempt to level before installation is eliminated.

### Anti drip system



An exclusive anti-drip system is fitted to the front of the basket to prevent irritating drips on the floor as the basket is extracted. It is designed to

improve the drying performance of the dishwasher.

WASH EFFICIENCY

Smeg research has resulted in two excellent wash systems: Orbital for 60cm models, and the SwingWash for 45cm dishwashers.



ORBITAL WASH SYSTEM: This system consists of a **double spray arm**, with contra-action rotation, which distributes water evenly throughout the cavity. The spray arm jets are perfectly shaped to direct the water with precision, ensuring an excellent wash quality and a greatly reduced noise level.



SWING WASH SYSTEM: The new SwingWash spray system further improves the wash coverage in the rectangular shaped tank by the addition of an extra spray arm which directs water towards the corners, swinging alternately between the rear and the front of the machine during the cycle.

EXPLAINING THE EU ENERGY LABEL



The new EU energy label provides consumers with accurate, recognisable and comparable information on domestic household products regarding energy consumption, performance and other essential characteristics.

The new labels now include:

- 7 energy classes maximum: from A+++ to D
- Annual energy and water consumption (no longer per cycle)
- Noise emissions in decibels
- Drying efficiency class
- All dishwashers must now have an 'A' class cleaning performance. For this reason cleaning performance is no longer indicated on the label.



Smeg dishwashers with A+, A++ or A+++ rating are highlighted with one of the following symbols.

ENERGY & WATER SAVINGS



ENERSAVE

At the end of the drying cycle a special device slowly automatically opens the door a few centimetres which **ensures perfect drying** and can **save up to 20% of energy** on some models.



AQUATEST: An electronic infrared sensor measures the clarity of the water during an Auto programme, and automatically ensures the **minimum consumption of water and energy** during the load. Models with Aquatest will

188 have at least one Auto programme.



AUTO: The length of an

Auto programme depends on the need for a pre-wash and the number of rinses required, as monitored by the Aquatest, which automatically selects the programme most suitable for the degree of food debris found on the dishes.

A dishwasher is considered an essential item in a modern kitchen. A comprehensive choice of model features and programme options ensures that Smeg dishwashers offer efficiency, convenience and complete peace of mind. Continuous research and development results in high quality appliances with energy saving features and excellent performance.

## INCREASED CONVENIENCE

Smeg have developed a number of features and options that are intended to **save time or effort**, and allow the appliance to run at the convenience of the user. Each model has a selection of programmes with wash times from as little as 27 minutes up to a much longer, but **extremely energy efficient** 180 minutes, however an average family wash is likely to take between 95 and 120 minutes, estimated at approximately 100 minutes.



**FINGER-FRIENDLY STAINLESS STEEL:** The st/steel material used on the exteriors of Smeg dishwashers has a finger-friendly finish to assist in maintaining the surfaces in a pristine condition.



**QUICK TIME:** The Quick Time option can be selected in conjunction with all programmes except the pre-wash in order to reduce the length of the wash cycle up to 55%.

By using higher temperatures and an intense mechanical spray action, Quick Time is able to save valuable time.



The 1/2 load **FLEXIZONE** allows you to wash a reduced load saving energy, water and time and there are no restrictions on where the items are placed.

To assist in the selection of the right dishwasher a number of symbols now appear beneath each model, which act as an aid to checking and comparing the products on offer. Some examples are shown here, but details of the full range of symbols can be found at the back of the brochure.



**FLEXITABS:** Regardless of the type of detergent used, the wash cycle adjusts to give the best possible results every time.



**DELAY TIMER:** A delay timer can postpone the start of the programme by up to 24 hours, for convenience and also to take advantage of off-peak energy periods



**CRYSTAL:** The crystal cycle is a particular programme designed especially for glass ware and delicate dishes with light dirt.



**RAPID 27 MINS:** A quick programme which takes just 27 minutes, suitable for a lightly soiled load.



**STRONG & FAST:** This special programme takes less than 1 hour to eliminate the most stubborn dirt and dried on residues.

## QUIET OPERATION

In depth research and attention to detail has enabled Smeg dishwashers to become exceptionally quiet. The motor and pump are encased in special panels to absorb the noise and vibration, resulting in a noise level as low as 42dB(A) re 1 pW.



A dishwasher being monitored for sound under very specific test conditions in a laboratory before being assigned an official noise level.

## PROTECTION



**TOTAL ACQUASTOP:** In addition to the partial Acquastop protection present in all Smeg dishwashers, some models have an electronic device fitted to the water intake hose, which monitors water levels in the machine, detects leaks in the hose and switches off the water supply immediately when necessary.



When the **HYCLEAN** option (or Ultracleanse programme) is selected, the dishwasher performs a final 10 minute rinse at a high temperature of 70°C, eliminating virtually all bacteria to achieve the highest possible standards of cleanliness. The Hyclean option can be selected with almost all cycles at temperatures above 50°C.

# DF13SS

60CM DISHWASHER WITH HIDDEN CONTROLS,  
FULLY CLAD IN ST/STEEL



### MODEL FEATURES



### PROGRAMMES & OPTIONS



13 place settings

10 programmes; Soak, Crystal, ECO, Rapid 27 mins, ECO Quick, Delicate Quick, Normal Quick, Auto 45-65, Strong & fast, Super 5 temperatures (38° 45° 50° 65° 70°)

Consumption (based on 280 cycles):

Water: 2520 litres per annum

Energy: 233 kWh/year

Noise level: 39 dB (A) RE 1 pW

Maximum plate diameter 30cm

Average wash time approximately 100 mins, but Quick Time can reduce this by up to 55%

Handle co-ordinates with other Classic style products

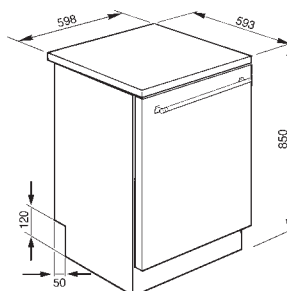



**DF13SS**

## DC134LSS

60CM DISHWASHER,  
SILVER WITH ST/STEEL DOOR



## DC134LB

60CM DISHWASHER,  
BLACK



### MODEL FEATURES



### PROGRAMMES & OPTIONS

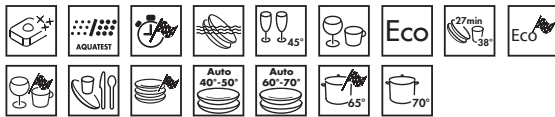

13 place settings

13 programmes: Soak, Crystal, Delicate, ECO, Rapid 27 mins, Eco Quick, Delicate Quick, Daily Quick, Normal Quick, Auto 40-50, Auto 60-70, Strong & fast, Super

5 temperatures (38° 45° 50° 65° 70°)

Consumption (based on 280 cycles):

Water: 2744 litres per annum

Energy: 292 kW/year

Noise level: 43 dB (A) RE 1 pW

Maximum plate diameter 30cm

Average wash time approximately 100 mins, but Quick Time can reduce this by up to 55%

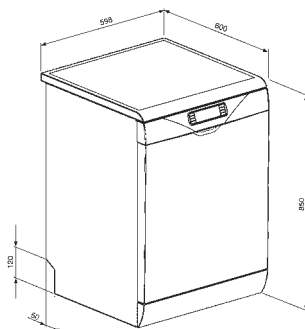

## DC134LW

60CM DISHWASHER,  
WHITE



## DC122SS-1

60CM DISHWASHER,  
SILVER WITH ST/STEEL DOOR



## DC122W-1

60CM DISHWASHER,  
WHITE



### MODEL FEATURES



### PROGRAMMES & OPTIONS



12 place settings  
5 programmes: Soak, Normal, ECO, Rapid 27 mins, Super  
5 temperatures (38°, 45°, 50°, 65°, 70°)  
Consumption (based on 280 cycles):  
Water: 3360 litres per annum  
Energy: 286 kW/year  
Noise level: 49 dB (A) RE 1 pW

Maximum plate diameter 30cm  
Average wash time approximately 100 mins

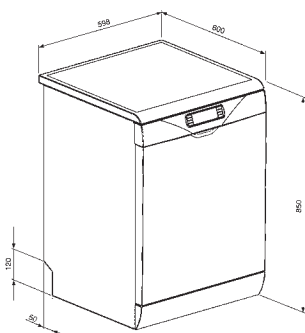

## DC122B-1

60CM DISHWASHER,  
BLACK



FREESTANDING

DISHWASHERS

## DF4SS-1

45CM DISHWASHER WITH HIDDEN CONTROLS,  
FULLY CLAD IN ST/STEEL



### MODEL FEATURES



### PROGRAMMES & OPTIONS



10 place settings  
10 programmes: Soak, Rapid 27 mins, Crystal, Delicate Quick, ECO, ECO Quick, Auto 45-65, Normal Quick, Super, Strong & fast  
4 temperatures (45° 55° 65° 70°)  
Consumption (based on 280 cycles):  
Water: 2660 litres per annum  
Energy: 236 kWh/year  
Noise level: 46 dB (A) RE 1 pW

Maximum plate diameter 30cm  
Average wash time approximately 100 mins

Handle co-ordinates with other Classic style products

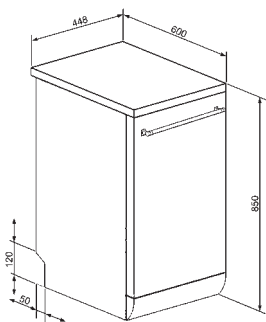

## D4B-1

45CM DISHWASHER,  
BLACK



### MODEL FEATURES



### PROGRAMMES & OPTIONS



10 place settings  
10 programmes: Soak, Rapid 27 mins, Crystal, Delicate Quick, ECO, ECO Quick, Auto 45-65, Normal Quick, Super, Strong & fast  
5 temperatures (38° 45° 55° 65° 70°)  
Consumption (based on 280 cycles):  
Water: 2660 litres per annum  
Energy: 236 kWh/year  
Noise level: 46 dB (A) RE 1 pW

Maximum plate diameter 30cm  
Average wash time approximately 100 mins

Electronic display shows options selected, salt & rinse aid requirements, length of programme and time left to end of cycle



D4SS-1  
fully clad in st/steel

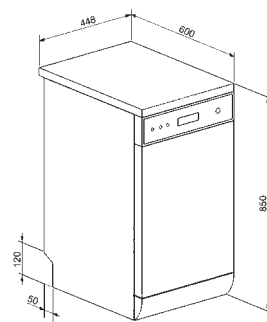

D4SS-1  
D4B-1



**DF45S-1**

## DF6FABVE1

60CM 50's RETRO FREESTANDING DISHWASHER IN LIME GREEN



## DI6FABRO1

60CM 50's RETRO BUILT-IN DISHWASHER IN PINK



### MODEL FEATURES



### PROGRAMME OPTIONS



13 place settings  
 9 programmes: Soak, Crystal, ECO, Rapid 27 mins, Eco Quick, Normal Quick, Auto 60-70, Strong & fast, Super  
 5 temperatures (38° 45° 50° 65° 70°)  
 Consumption (based on 280 cycles):  
 Water: 2800 litres per annum  
 Energy: 258 kW/year  
 Noise level: 42 dB (A) RE 1 pW

Maximum plate diameter 30cm  
 Average wash time approximately 100 mins, but Quick Time can reduce this by up to 55%

Colour co-ordinating cutlery basket and racks

Retro fires, refrigeration and laundry are also available



DF6FABRO1  
 Pink

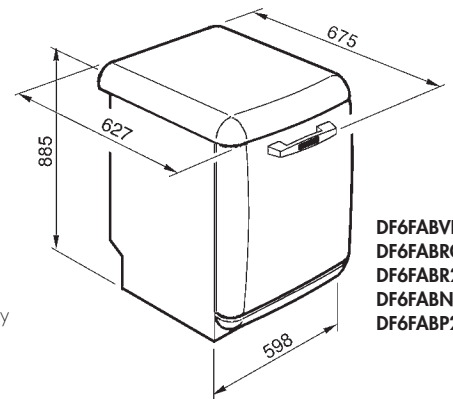

NB: This dishwasher will not fit under a standard worktop. Please check measurements carefully and choose the built-in version if there is insufficient height.

DF6FABVE1  
 DF6FABRO1  
 DF6FABR2  
 DF6FABNE2  
 DF6FABP2

NB: DF6FABVE1, DF6FABRO1, DI6FABRO1 - available whilst stocks last

## DF6FABR2

60CM 50's RETRO FREESTANDING DISHWASHER IN RED



### MODEL FEATURES



### PROGRAMME OPTIONS

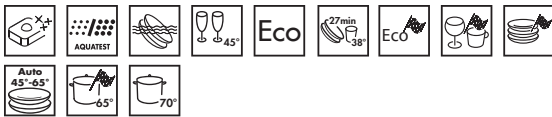

13 place settings

10 programmes: Soak, Crystal, ECO, Rapid 27 mins, Eco Quick, Delicate Quick, Normal Quick, Auto 45-65, Strong & fast, Super 5 temperatures (38° 45° 50° 65° 70°)

Consumption (based on 280 cycles):

Water: 2744 litres per annum

Energy: 292 kW/year

Noise level: 43 dB (A) RE 1 pV

Maximum plate diameter 30cm

Average wash time approximately 100 mins, but Quick Time can reduce this by up to 55%

Colour co-ordinating cutlery basket and racks

Retro fires, refrigeration and laundry are also available



DF6FABNE2  
Black



DF6FABP2  
Cream

## DI6FABP2

60CM 50's RETRO BUILT-IN DISHWASHER IN CREAM

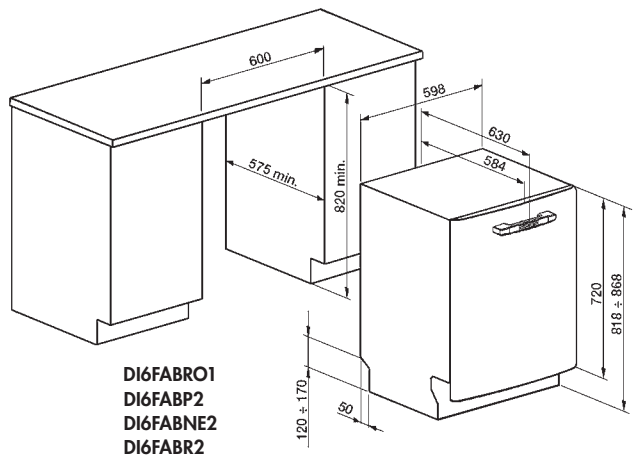

DI6FABO1  
DI6FABP2  
DI6FABNE2  
DI6FABR2

NB: This dishwasher has rear levelling feet adjustable from the front.



DI6FABR2  
Red



DI6FABNE2  
Black

For additional information see pages 234-244

# DI6SS-1

60CM INTEGRATED DISHWASHER WITH ST/STEEL DOOR AND HANDLE



## MODEL FEATURES

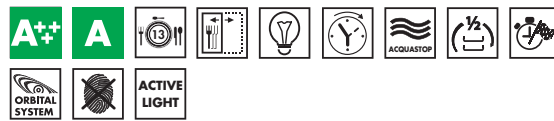

## PROGRAMMES & OPTIONS



13 place settings

10 programmes: Soak, Crystal, ECO, Rapid 27 mins, Eco Quick, Delicate Quick, Normal Quick, Auto 45-65, Strong & Fast, Super 5 temperatures (38° 45° 50° 65° 70°)

Consumption (based on 280 cycles):

Water: 2520 litres per annum

Energy: 230 kW/year

Noise level: 39 dB (A) RE 1 Pw

Rear levelling feet adjustable from the front

Handle co-ordinates with other Classic style products

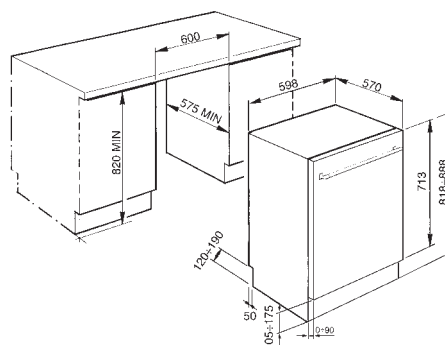

# DI6MAX-1

# MAXI HEIGHT

60CM MAXI HEIGHT FULLY INTEGRATED DISHWASHER



### MODEL FEATURES

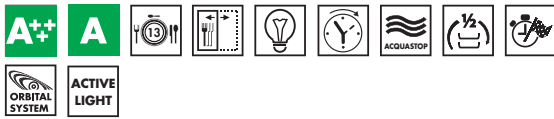

### PROGRAMME & OPTIONS



#### 13 place settings

10 programmes: Soak, Crystal, Normal, ECO, Rapid 27 mins, Eco Quick, Delicate Quick, Normal Quick, Strong and Fast, Super 5 temperatures (38° 45° 55° 65° 70°)

Consumption (based on 280 cycles):

Water: 2520 litres per annum

Energy: 230 kW/year

Noise level: 44 dB (A) RE 1 Pw

Rear levelling feet adjustable from the front

Maximum plate diameter 35cm

Average wash time approximately 100 mins, but Quick Time can reduce this by up to 55%

Maxi height of 86cm for extra capacity

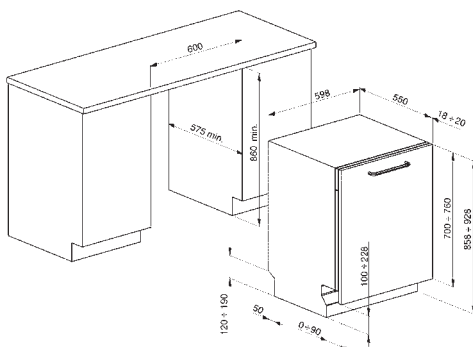

# DI6013NH-1

# HANDLE-LESS

60CM FULLY INTEGRATED DISHWASHER



### MODEL FEATURES

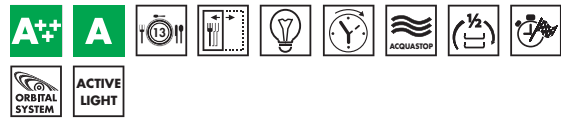

### PROGRAMME & OPTIONS

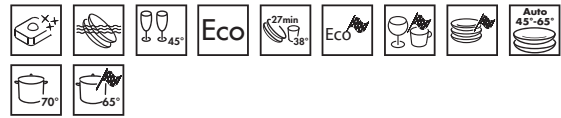

#### 13 place settings

10 programmes: Soak, Crystal, ECO, Rapid 27 mins, Eco Quick, Delicate Quick, Normal Quick, Auto 45-65, Strong & Fast, Super 5 temperatures (38° 45° 50° 65° 70°)

Consumption (based on 280 cycles):

Water: 2520 litres per annum

Energy: 230 kW/year

Noise level: 44 dB (A) RE 1 Pw

Press and release door opening technology (automatic opening handle-less door)

Rear levelling feet adjustable from the front

Maximum plate diameter 30cm

Average wash time approximately 100 mins, but Quick Time can reduce this by up to 55%

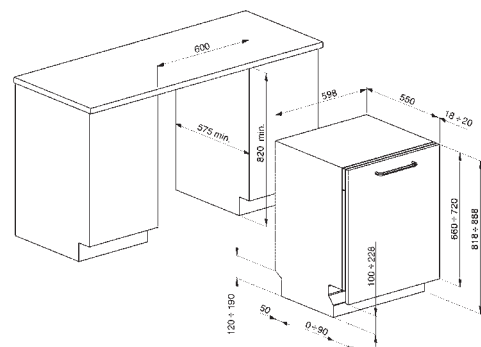

For additional information see pages 234-244

## DI6013-1

60CM FULLY INTEGRATED DISHWASHER



### MODEL FEATURES



### PROGRAMMES & OPTIONS



13 place settings

10 programmes: Soak, Crystal, Normal, ECO, Rapid 27 mins, Eco Quick, Delicate Quick, Normal Quick, Strong & Fast, Super 5 temperatures (38° 45° 50° 65° 70°)

Consumption (based on 280 cycles):

Water: 2520 litres per annum

Energy: 230 kW/year

Noise level: 43 dB (A) RE 1 Pw

Rear levelling feet adjustable from the front

Maximum plate diameter 30cm

Average wash time approximately 100 mins, but Quick Time can reduce this by up to 55%

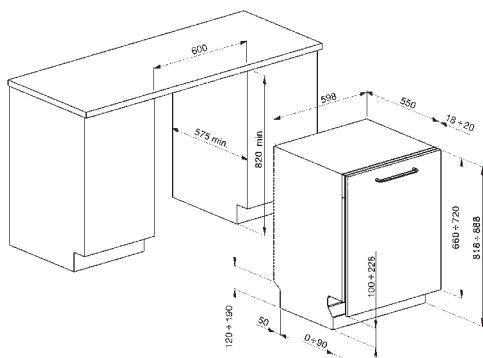

## DI6012-1

60CM FULLY INTEGRATED DISHWASHER



### MODEL FEATURES



### PROGRAMMES & OPTIONS



12 place settings

5 programmes: Soak, Normal, ECO, Rapid 27 mins, Super 5 temperatures (38° 45° 50° 65° 70°)

Consumption (based on 280 cycles):

Water: 3360 litres per annum

Energy: 289 kW/year

Noise level: 48 dB (A) RE 1 Pw

Rear levelling feet adjustable from the front

Maximum plate diameter 30cm

Average wash time approximately 100 mins

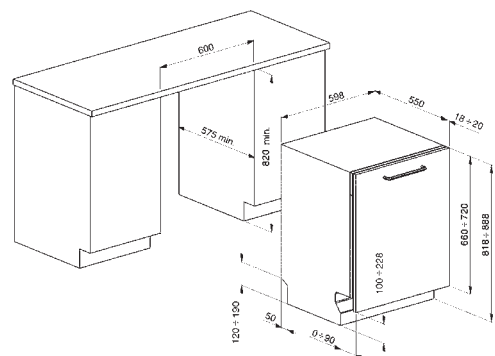

## DI4-1

45CM FULLY INTEGRATED DISHWASHER



### MODEL FEATURES



### PROGRAMME OPTIONS



10 place settings  
 10 programmes: Soak, Crystal, ECO, Rapid 27 min, ECO quick, Delicate Quick, Normal quick, Auto 45-65, Strong & fast, Super.  
 4 temperatures (45° 50° 65° 70°)  
 Consumption (based on 280 cycles):  
 Water: 2660 litres per annum  
 Energy: 236 kWh/ year  
 Noise Level: 46 dB (A) RE 1 Pw

Maximum plate diameter 30cm  
 Average wash time approximately 100 mins

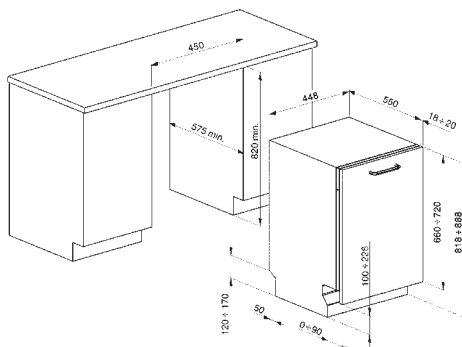

## KIT4CX-1

45CM DOOR PANEL KIT, ST/STEEL



DI4-1 dishwasher and KIT4CX-1 door panel can be purchased separately, or alternatively they are sold together as a kit called DI45CL to create a built in Classic 45cm dishwasher.

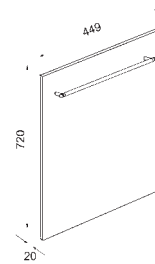

## SMEG LAUNDRY, WASHING & DRYING EXPERTISE



Offering **excellent performance** and sought after style, the distinctive design of Smeg washing machines and washer dryers make them not simply appliances useful for doing the chores, but also inspirational pieces of kitchen furniture combining practicality with technology and grace.

## LAUNDRY RANGE – OPTIMUM CHOICE

Smeg offer a wide choice of freestanding laundry products – from 50's Retro style washing machines, designed to coordinate with the iconic FAB refrigeration range, to stylish st/steel or white models. Smeg also offer built in laundry products to complete the range.



50'S RETRO STYLE



STAINLESS STEEL



WHITE



BUILT IN

**Current EU energy labels** have been designed for washing machines whereby pictograms highlight selected performances such as annual water and energy consumptions based on 220 cycles (an important change from previous washing machine energy labels which were shown per cycle), and noise level on washing & spinning phases. All machines are now rated **"A"** for **washing efficiency class** as a standard, therefore it is no longer required on the energy label. The energy label for Washer-dryers has not changed; showing performances per cycle.

### UNIVERSAL FEATURES

All Smeg laundry products are built to a high standard and have been researched and developed over time to include a number of characteristics which are common to all models in our range, and these include

- stainless steel drum and polypropylene tank
- self clean detergent drawer
- extra large 300mm porthole
- automatic variable load
- total acquastop
- delay timer
- variable spin speed



Besides choosing the appropriate washing programme with the main programme control knob, the smaller buttons can be used to select the washing temperature, spin speed up to 1400 rpm, and check the option selector for such choices as FlexiTime, delay timer or extra rinse, amongst others. The LCD display shows the time and progression for the programme selected and recommended load indicates the optimal load weight for the chosen cycle to achieve the best washing results.

### CHECK & COMPARE

To assist in the selection of the right laundry appliance a number of symbols now appear beneath each model, which act as an aid to checking and comparing the products on offer. Some examples are shown here, but details of the full range of symbols can be found at the back of the brochure.



The **FlexiTime** option allows the user to reduce the time of the cycle selected, providing extra control.



**Night:** an ideal programme for those who want to take advantage of off-peak energy periods, this cycle is particularly quiet due to slower rotations of the drum.



**Super fast 15 min:** a programme designed to wash small amounts of laundry fast, ideal for washing lightly soiled garments.



**Jeans:** a washing cycle which is kind to the colour and fabric of denim whilst minimising wrinkles.



A **cleaning programme** has been created to maintain the performance of washer/dryers. The display shows automatically when cleaning is required.



The **Extra rinse** option: can be added to the selected programme when more thorough cleansing of special fabrics is needed.

### FRONT ADJUSTABLE LEVELLING FEET

Built in models include **rear levelling feet that can be easily adjusted from the front**, allowing you to alter the height of the machine once integrated into the kitchen furniture. Levelling the appliance is essential for ensuring correct operation of the washer, and with this innovative yet simple feature the need to level before installation is eliminated.

# WMFABRO1

60CM FREESTANDING 50'S STYLE WASHING MACHINE, PINK



## FEATURES



## SPECIAL PROGRAMMES



Electronic display includes 24h delay timer and **recommended load**  
 7 buttons: start/pause, child lock, delay timer, option selector, confirmation selector, spin speed, and temperature selector  
 Electronic display shows programme selected and progression  
 15 washing programmes  
 Customised options; variable temperature, spin speed up to 1400 rpm and option selector including **FlexiTime**  
**Max 7kg of dry laundry**

Consumption (220 cycles)  
 Water: 10340 litres/ per annum  
 Energy: 222kWh / per annum  
 Noise level washing phase 59 dB(A) re 1 pW  
 Noise level spinning phase 78 dB(A) re 1 pW  
 Nominal power: 2.00kW  
 Energy efficiency class: A+  
 Spin drying performance: B

Retro fires, refrigeration and dishwashers are also available



WMFABAZ1  
Pastel blue

WMFABP1  
Cream

WMFABNE1  
Black

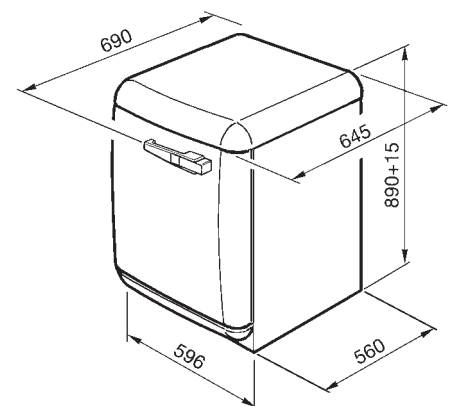

NB: This washing machine will not fit under a standard work top. Please check measurements carefully.

## WMF147X

60CM FREESTANDING WASHING MACHINE,  
STAINLESS STEEL



### FEATURES



### SPECIAL PROGRAMMES



Electronic display includes 24h delay timer and **recommended load**  
6 buttons: start/pause, child lock, option selector, confirmation selector, spin speed, and temperature selector  
Electronic display shows programme selected and progression  
15 washing programmes  
Customised options; variable temperature, spin speed up to 1400 rpm and option selector including **FlexiTime**  
**Max 7kg of dry laundry**

Consumption (220 cycles)  
Water: 10340 litres/ per annum  
Energy: 222kWh / per annum  
Noise level washing phase: 59dB (A) re 1 pW  
Noise level spinning phase: 75dB (A) re 1 pW  
Nominal power: 2.00kW  
Energy efficiency class: A+  
Spin drying performance: B

## WDF147XS

60CM FREESTANDING WASHER DRYER,  
STAINLESS STEEL



### FEATURES



### SPECIAL PROGRAMMES



Electronic display includes 24h delay timer and **recommended load**  
6 buttons: start/pause, drying, option selector, confirmation selector, spin speed, and temperature selector  
Electronic display shows programme selected and progression  
15 washing programmes  
Customised options; variable temperature, spin speed up to 1400 rpm and option selector including **FlexiTime**  
6 automatic drying programmes  
**Humidity sensor** that automatically calculates dry time  
**Clean programme**  
**Max washing capacity: 7kg**  
**Max drying capacity: 4kg**

Consumption (per cycle):  
For washing only: water: 47 litres, energy: 1.19kW/h  
For complete 7Kg wash + 2 sessions of 4Kg drying: Water 99 litres, energy: 5.6kW/h  
Nominal power: 2.00kW  
Energy efficiency class: B  
Washing performance: A

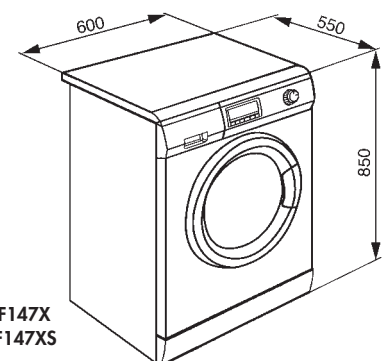

WMF147X  
WDF147XS

## WML148UK

60CM FREESTANDING WASHING MACHINE,  
WHITE



### FEATURES



### SPECIAL PROGRAMMES



Electronic display includes 24h delay timer and **recommended load**  
6 buttons: start/pause, child lock, option selector, confirmation selector, spin speed, and temperature selector  
Electronic display shows programme selected and progression  
15 washing programmes  
Customised options; variable temperature, spin speed up to 1400 rpm and option selector including **FlexiTime**  
**Max 7kg of dry laundry**

Consumption (220 cycles)  
Water: 10340 litres/ per annum  
Energy: 222kWh / per annum  
Noise level washing phase: 59dB (A) re 1 pW  
Noise level spinning phase: 75dB (A) re 1 pW  
Nominal power: 2.00kW  
Energy efficiency class: A+  
Spin drying performance: B

OPTIONAL EXTRA:  
**WSMZ20310** - stacking kit to be used to stack CDL73UK in column, on top of WML148UK

## CDL73UK

60CM FREESTANDING TUMBLE DRYER,  
WHITE



### FEATURES



### SPECIAL PROGRAMMES



Electronic display with Soft Touch controls to show programme selected and progression  
11 drying programmes  
Customised options; variable temperature and delay start  
24h delay timer  
End of cycle indicator  
Humidity sensor that automatically calculates dry time  
Clean programme and indicator to show condenser container full  
Internal light

Max drying capacity: 7kg

Consumption (per cycle):  
For standard cycle: 4.20kWh

Nominal power: 2.80kW  
Energy efficiency class: B

OPTIONAL EXTRA:  
**WSMZ20310** - stacking kit to be used to stack CDL73UK in column, on top of WML148UK

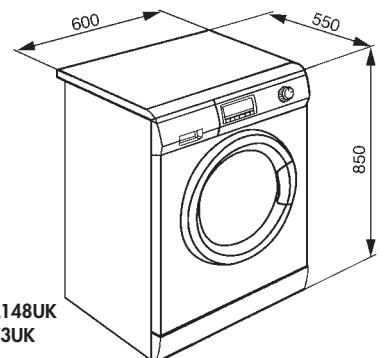

WML148UK  
CDL73UK



**CDL73UK  
WSMZ20310  
WML148UK**

## WMF147

FREE-STANDING WASHING MACHINE,  
WHITE



### FEATURES



### SPECIAL PROGRAMMES



Electronic display includes 24h delay timer and **recommended load**  
6 Buttons: Start/pause, child lock, confirm options, option selector,  
spin speed, temperature selection  
Electronic display shows programme selected and progression  
15 washing programmes  
Customised options; variable temperature, spin speed up to  
1400rpm and option selector including **FlexiTime**  
**Max 7Kg of dry laundry**

Consumption (220 cycles)  
Water: 10340 litres/ per annum  
Energy: 222kWh / per annum  
Noise level washing phase: 59 dB(A) 1 re pW  
Noise level spinning phase: 75 dB(A) 1 re pW  
Nominal power: 2.00kW  
Energy efficiency class: A+  
Spin drying performance: B

## WDF147S

FREE-STANDING WASHER-DRYER,  
WHITE



### FEATURES



### SPECIAL PROGRAMMES



Electronic display includes 24h delay timer and **recommended load**  
6 Buttons: Start/pause, drying, confirm options, options selector,  
spin speed, temperature selector  
Electronic display shows programme selected and progression  
15 wash programmes  
Customised options; variable temperature, spin speed up to  
1400rpm and option selector including **FlexiTime**  
6 automatic drying programmes  
**Humidity sensor** that automatically calculates dry time  
**Clean programme**  
**Max washing capacity: 7kg**  
**Max drying capacity: 4kg**

Consumption (per cycle):  
For washing only: water: 47 litres, energy: 1.19kW/h  
For complete 7Kg wash + 2 sessions of 4kg drying: water:  
99 litres, energy: 5.6kW/h  
Nominal power: 2.00 kW  
Energy efficiency class: B  
Washing performance: A

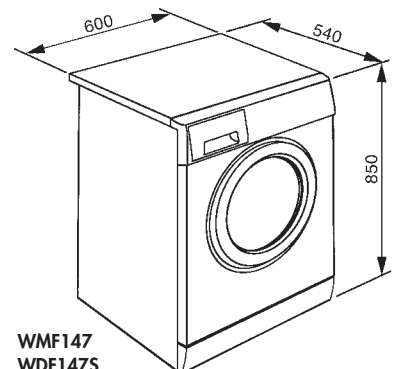

WMF147  
WDF147S

# WMI147

FULLY INTEGRATED WASHING MACHINE



## FEATURES



## SPECIAL PROGRAMMES



Electronic display includes 24h delay timer and **recommended load**  
 7 buttons: start/pause, child lock, delay timer, confirm options, option selector, spin speed, temperature selector  
 Door opening release  
 Electronic display shows programme selected and progression  
 15 washing programmes  
 Customised options; variable temperature, spin speed up to 1400rpm, and option selector including **FlexiTime**  
**Max 7Kg of dry laundry**  
**Rear levelling feet adjustable from the front**

Consumption (220 cycles)  
 Water: 10340 litres/ per annum  
 Energy: 222kWh / per annum  
 Noise level washing phase: 56 dB(A) 1 re pW  
 Noise level spinning phase: 72 dB(A) 1 re pW  
 Nominal power: 2.00kW  
 Energy efficiency class: A+  
 Spin drying performance: B

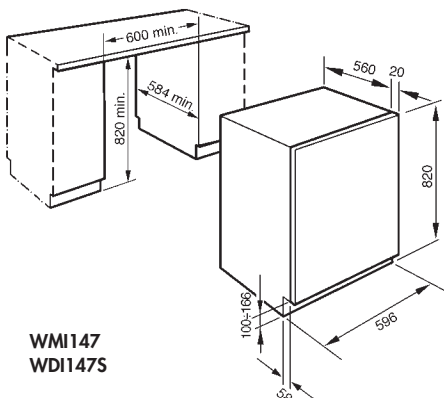

WMI147  
WDI147S

# WDI147S

FULLY INTEGRATED WASHER/DRYER



## FEATURES



## SPECIAL PROGRAMMES

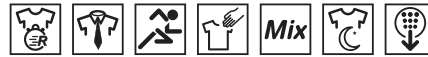

Electronic display includes 24h delay timer and **recommended load**  
 7 buttons: start/pause, drying, delay timer, confirm options, options selector, spin speed, temperature selector  
 Door opening release  
 Electronic display shows programme selected and progression  
 12 washing programmes  
 Customised options; variable temperature, spin speed up to 1400rpm, and option selector including **FlexiTime**  
**6 automatic drying programmes**  
**Humidity sensor** that automatically calculates dry time  
**Clean programme**  
**Max washing capacity: 7Kg dry laundry**  
**Max drying capacity: 4Kg**  
 Condenser drying  
**Rear levelling feet adjustable from the front**

Consumption (per cycle):  
 For washing only: water: 47 litres, energy: 1.19kw/h  
 For complete 7Kg wash + 2 sessions of 4kg drying: water: 99 litres, energy: 5.6kw/h  
 Nominal power: 2.00 kw  
 Energy efficiency class: B  
 Washing performance: A

## SMEG SINKS AND TAPS, QUALITY DESIGN AESTHETICS



Smeg sinks and taps are high quality products with captivating design and aesthetics. The collection encompasses a number of design orientated and functional sinks that will make an eye-catching style statement in any kitchen.

## WELL DESIGNED SINKS, A FINISHING TOUCH

In addition to all the other appliances, the Smeg portfolio includes a wide range of sinks to put the finishing touch to your kitchen. The sinks are well designed and constructed of **high quality stainless steel** in a substantial thickness, resulting in a long working life. The majority of Smeg sinks are **210mm deep**, approximately 40% deeper than most other sinks on the market, offering a greater capacity and versatility of use.

### Inset sinks in 4 distinct styles



**IRIS:** Soft rounded corners with deep bowls and glass boards included. New this year are red or cream versions, colours that perfectly coordinate with Smeg 50's Retro Style range.



**MIRA:** Features minimum radius 15mm corners, almost square, but simple to clean whilst a very chic design.



**ALBA:** Classic design which co-ordinates with any kitchen style, many versions available.

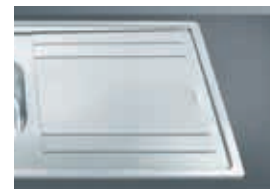

**RIGAE:** Simple style at a modest price, with a choice of 4 models.

### Undermount - a popular choice

Undermount sink models are widely chosen for installations with granite and composition worktops to give an understated but very practical and stylish appearance. Available in two of the three inset designs, with the addition of the **modern square cornered QUADRA**.



QUADRA



MIRA



ALBA

## NOT JUST THE KITCHEN SINK



Choosing a sink is not complete until a tap has been selected to co-ordinate with the kitchen design. Smeg offers taps in a many styles with finishes in brushed stainless steel, chrome and brushed nickel. The range includes standard single lever and dual flow mixers, models with pull out sprays, and even a 3-in-1 tap which provides steaming 98°C water and the usual hot and cold from the same tap.

Accessories should not be forgotten either: chopping boards in hardwood or glass to match with Linea kitchen appliances, and stainless steel drainer baskets or colanders.

The ALBA SRO3416 sink pictured here is accessorized with the brushed stainless steel SIENA tap and the TLC34 accessory pack – hardwood and white plastic chopping boards and a stainless steel colander to fit the half bowl.

## VSTQ72-2

"QUADRA" SINGLE BOWL UNDERMOUNT SINK



Bowl depth: 210mm  
Bowl width: 1 x 720mm  
Drain: 3.5"

## VSTQ50-2

"QUADRA" SINGLE BOWL UNDERMOUNT SINK



Bowl depth: 210mm  
Bowl width: 1 x 500mm  
Drain: 3.5"

## VSTQ40-2

"QUADRA" SINGLE BOWL UNDERMOUNT SINK



Bowl depth: 210mm  
Bowl width: 1 x 400mm  
Drain: 3.5"

## VSTQ20

"QUADRA" SINGLE BOWL UNDERMOUNT SINK



Bowl depth: 210mm  
Bowl width: 1 x 200mm  
Drain: 3.5"

## QUADRA UNDERMOUNT MODELS:

ALL SINKS ON THESE PAGES FEATURE THE QUADRA DESIGN, AND DETAILS OF ALL THE VERSIONS AVAILABLE ARE SHOWN BELOW

Model	Drainer Position	Bowls	Minimum Base Unit (cm)
VSTQ72-2	N/A	1	80
VSTQ50-2	N/A	1	60
VSTQ40-2	N/A	1	50
VSTQ20	N/A	1	30

All sinks are supplied with overflows, drains, gaskets, fixing clips and dishwasher drain taps as standard accessories.

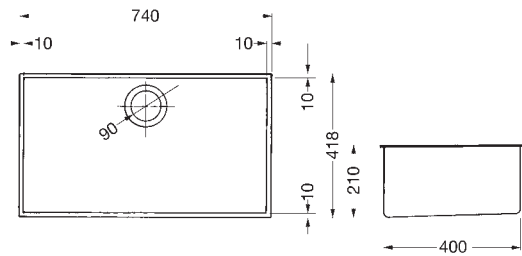

VSTQ72-2

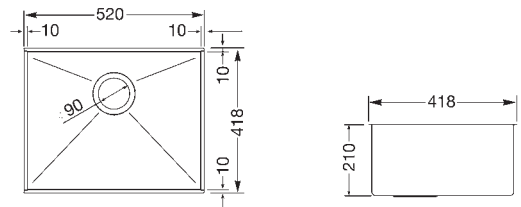

VSTQ50-2

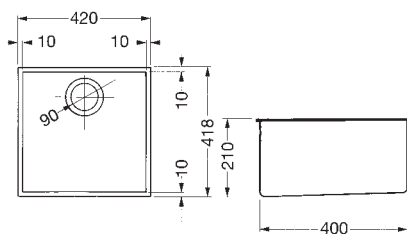
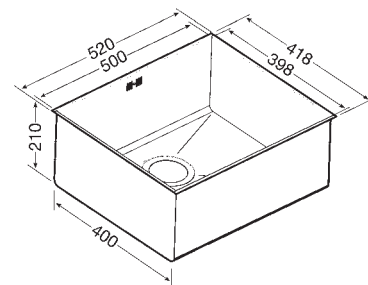
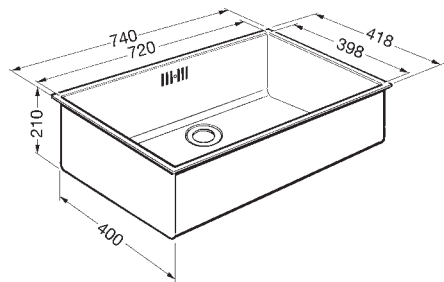

VSTQ40-2

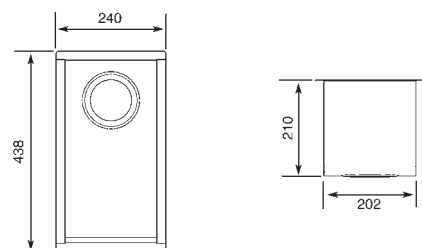

VSTQ20

## LD861D

"MIRA" SINGLE BOWL, SINGLE DRAINER ULTRA LOW PROFILE INSET SINK



Bowl depth: 200mm  
Bowl widths: 1 x 340mm  
Drain: 3.5"



## LD862

"MIRA" DOUBLE BOWL, ULTRA LOW PROFILE INSET SINK



Bowl depth: 200mm  
Bowl widths: 2 x 340mm  
Drain: 3.5"



## LD102D

"MIRA" 1.5 BOWL, SINGLE DRAINER ULTRA LOW PROFILE INSET SINK



Bowl depth: 200mm  
Bowl widths: 1 x 340mm, 1 x 150mm  
Drain: 3.5"



## LD116D

"MIRA" DOUBLE BOWL, SINGLE DRAINER ULTRA LOW PROFILE INSET SINK



Bowl depth: 200mm  
Bowl widths: 2 x 340mm  
Drain: 3.5"



## MIRA INSET MODELS:

ALL SINKS ON THESE PAGES FEATURE THE MIRA DESIGN, AND DETAILS OF ALL THE VERSIONS AVAILABLE ARE SHOWN BELOW

Model	Drainer Position	Bowls	Minimum Base Unit (cm)
LD861D	RH	1	50
LD861S	LH	1	50
LD862	N/A	2	80
LD102D	RH	1.5	60
LD102S	LH	1.5	60
LD116D	RH	2	90
LD116S	LH	2	90

All sinks are supplied with overflows, drains, gaskets, fixing clips and dishwasher drain taps as standard accessories.

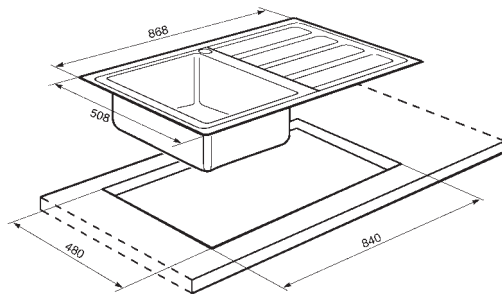
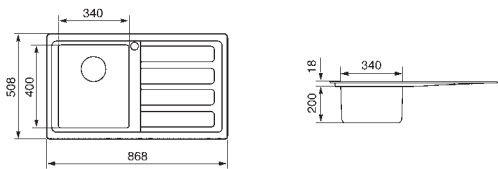

**LD861D**  
**LD861S**

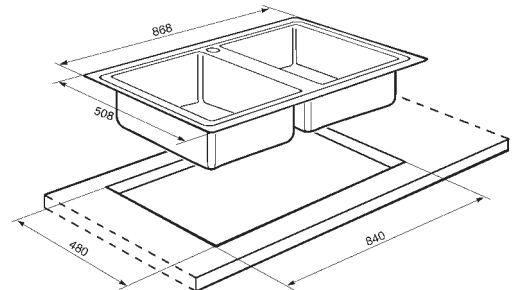
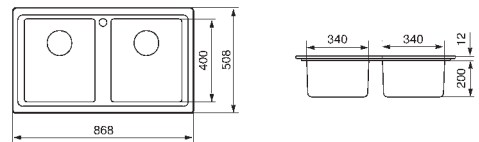

**LD862**

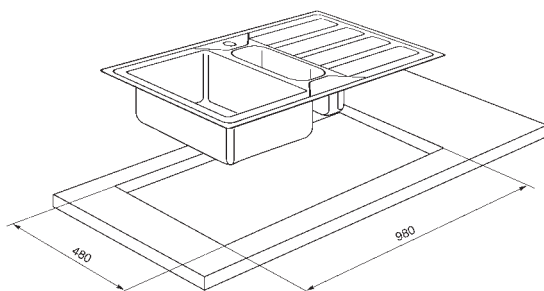
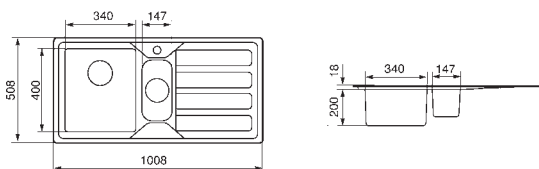

**LD102D**  
**LD102S**

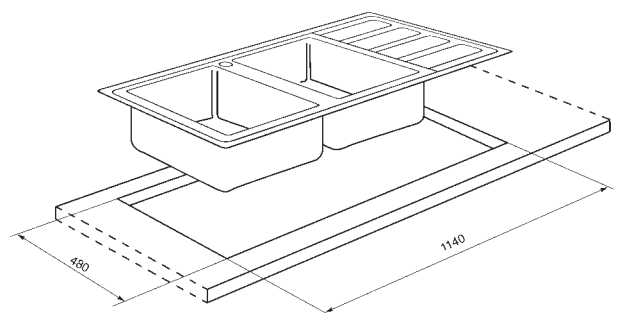
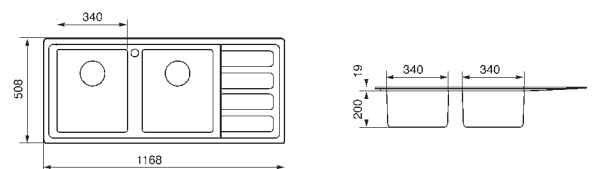

**LD116D**  
**LD116S**

## VSTR3434

"MIRA" DOUBLE BOWL UNDERMOUNT SINK



Bowl depth: 200mm  
Bowl widths: 2 x 340mm  
Drain: 3.5

## VSTR3416

"MIRA" 1.5 BOWL UNDERMOUNT SINK



Bowl depths: 200mm and 150mm  
Bowl widths: 1 x 340mm, 1 x 150mm  
Drain: 3.5

## VSTR50

"MIRA" SINGLE BOWL  
UNDERMOUNT SINK



Bowl depth: 200mm  
Bowl width: 500mm  
Drain: 3.5

## VSTR34

"MIRA" SINGLE BOWL  
UNDERMOUNT SINK



Bowl depth: 200mm  
Bowl width: 340mm  
Drain: 3.5

## VSTR16

"MIRA" HALF BOWL  
UNDERMOUNT SINK



Bowl depth: 150mm  
Bowl width: 150mm  
Drain: 3.5

# "MIRA" UNDERMOUNT

ALL SINKS ON THESE PAGES FEATURE THE "MIRA" UNDERMOUNT DESIGN, AND DETAILS OF ALL THE VERSIONS AVAILABLE ARE SHOWN BELOW.

Model	Drainer Position	Bowls	Minimum Base Unit (cm)
VSTR3434	N/A	2	80
VSTR3416	N/A	1.5	60
VSTR50	N/A	1	60
VSTR34	N/A	1	45
VSTR16	N/A	0.5	30

All sinks are supplied with overflows, drains, gaskets, fixing clips and dishwasher drain taps as standard accessories.

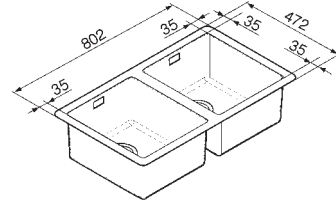
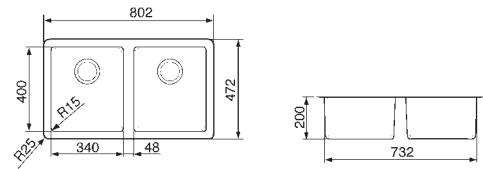

**VSTR3434**

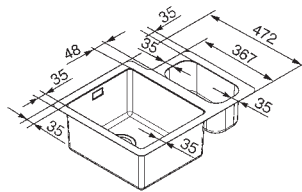
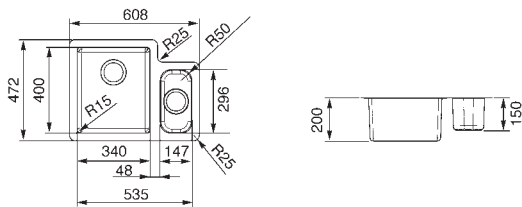

**VSTR3416**

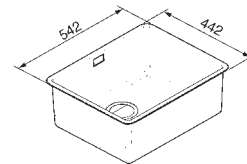
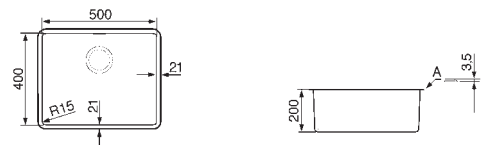

**VSTR50**

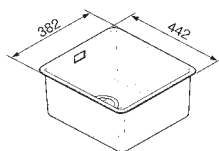

**VSTR34**

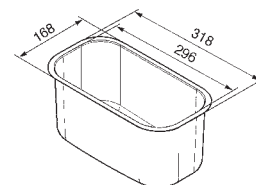
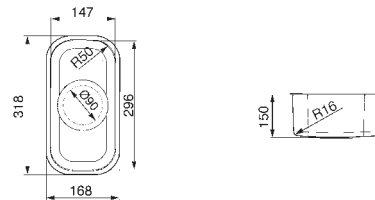

**VSTR16**

## LI915SGD

"IRIS" 1.5 BOWL SINGLE DRAINER INSET SINK WITH SILVER GLASS CHOPPING BOARDS



Bowl depth: 1 x 210mm, 1 x 150mm  
 Bowl width: 1 x 400mm, 1 x 147mm  
 Drain: 3.5»  
 Reversible glass/stainless steel chopping boards

ALSO AVAILABLE IN THE FOLLOWING VERSIONS:  
 Silver Glass chopping boards LH drainer **LI915SGS**  
 Black Glass chopping boards RH drainer **LI915ND**  
 Black Glass chopping boards LH drainer **LI915NS**  
 Red Glass chopping boards RH drainer **LI915RD**  
 Red Glass chopping boards LH drainer **LI915RS**  
 Cream Glass chopping boards RH drainer **LI915PD**  
 Cream Glass chopping boards LH drainer **LI915PS**

## LI92N

"IRIS" DOUBLE BOWL INSET SINK WITH BLACK GLASS CHOPPING BOARDS



Bowl depth: 210mm  
 Bowl width: 2 x 400mm  
 Drain: 3.5»  
 Reversible glass/stainless steel chopping boards

ALSO AVAILABLE IN THE FOLLOWING VERSION:  
 Silver Glass chopping boards **LI92SG**

## "IRIS" INSET

ALL SINKS ON THESE PAGES FEATURE THE "IRIS" INSET DESIGN, AND DETAILS OF ALL THE VERSIONS AVAILABLE ARE SHOWN BELOW.

Model	Drainer Position	Bowls	Minimum Base Unit (cm)
LI92N	N/A	2	90
LI92SG	N/A	2	90
LI915ND	RH	1.5	70
LI915NS	LH	1.5	70
LI915SGD	RH	1.5	70
LI915SGS	LH	1.5	70
LI915RD	RH	1.5	70
LI915RS	LH	1.5	70
LI915PD	RH	1.5	70
LI915PS	LH	1.5	70

All sinks are supplied with overflows, drains, gaskets, fixing clips and dishwasher drain taps as standard accessories.

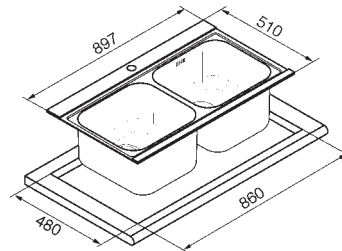
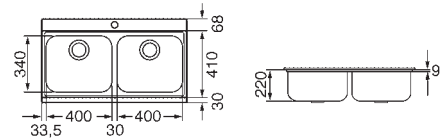

**LI92N**  
**LI92SG**

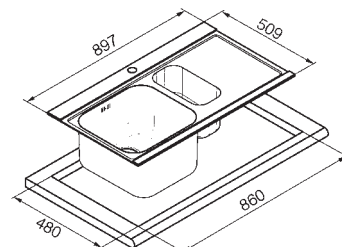
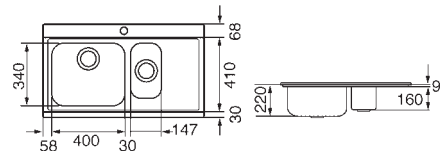

**LI915SGD**  
**LI915SGS**  
**LI915ND**  
**LI915NS**  
**LI915RD**  
**LI915RS**  
**LI915PD**  
**LI915PS**



LI915RD

IRIS (INSET)

SINKS

## SP3A

"ALBA" 2.5 BOWL CORNER INSET SINK



Bowl depth: 210mm  
Bowl widths: 2 x 340mm, 1 x 165mm  
Drain: 3.5"

ALSO AVAILABLE IN THE FOLLOWING VERSIONS:  
As above but without half bowl **SP2A**

## LG116D

"ALBA" DOUBLE BOWL, SINGLE DRAINER INSET SINK



Bowl depth: 210mm  
Bowl widths: 1 x 450mm, 1 x 300mm  
Drain: 3.5"

ALSO AVAILABLE IN THE FOLLOWING VERSIONS:  
With fabric finish LGM116D/LGM116S

## LL102D

"ALBA" 1.5 BOWL, SINGLE DRAINER INSET SINK



Bowl depth: 210mm  
Bowl widths: 1 x 340mm, 1 x 165mm  
Drain: 3.5"

ALSO AVAILABLE IN THE FOLLOWING VERSIONS:  
With fabric finish LM102D/LM102S

## LG861D

"ALBA" SINGLE BOWL, SINGLE DRAINER INSET SINK



Bowl depth: 210mm  
Bowl width: 1 x 450mm  
Drain: 3.5"

## SRO3416

"ALBA" 1.5 BOWL INSET SINK



Bowl depth: 210mm  
 Bowl widths: 1 x 340mm, 1 x 165mm  
 Drain: 3.5"  
 Pop-up waste

## VS34/P3

"ALBA" SINGLE BOWL INSET SINK



Bowl depth: 210mm  
 Bowl width: 1 x 340mm  
 Drain: 3.5"

NB: Previously marketed as FM34R-1

## 10I3P + 11I

"ALBA" ROUND BOWL INSET SINK AND INSET DRAINER



Bowl depth: 175mm  
 Bowl diameter: 430mm  
 Internal diameter: 375mm  
 Drain: 3.5"

## ALBA INSET MODELS:

ALL SINKS ON THESE PAGES FEATURE THE ALBA DESIGN, AND DETAILS OF ALL THE VERSIONS AVAILABLE ARE SHOWN BELOW

Model	Drainer Position	Bowls	Minimum Base Unit (cm)
SP3A	N/A	2.5	90
SP2A	N/A	2	90
LG116D	RH	2	90
LG116S	LH	2	90
LGM116D	RH	2	90
LGM116S	LH	2	90
LL102D	RH	1.5	60
LL102S	LH	1.5	60
LM102D	RH	1.5	60
LM102S	LH	1.5	60
SRO3416	N/A	1.5	60
LG861D	RH	1	60
LG861S	LH	1	60
10I3P	N/A	1	50
11I	N/A	N/A	50
VS34/P3	N/A	1	40

All sinks are supplied with overflows, drains, gaskets, fixing clips and dishwasher drain taps as standard accessories.

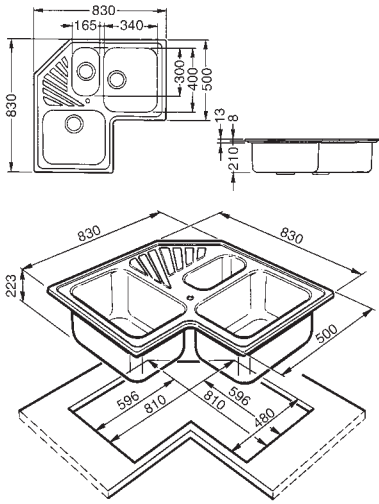

**SP3A**

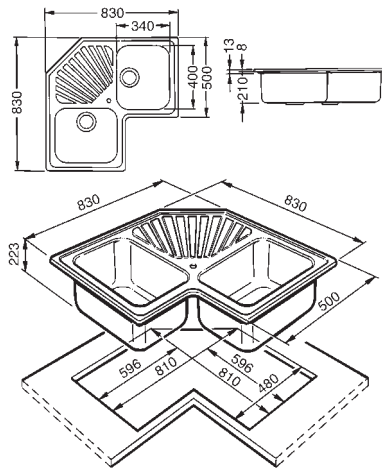

**SP2A**

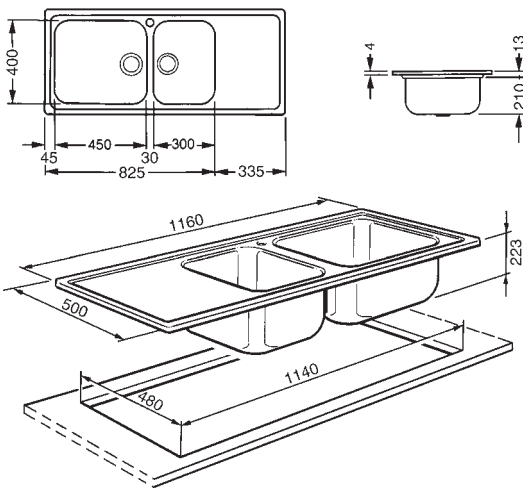

**LG116D  
LG116S  
LGM116D  
LGM116S**

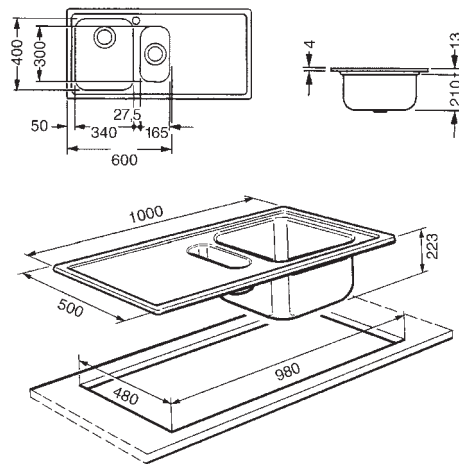

**LL102D  
LL102S  
LM102D  
LM102S**

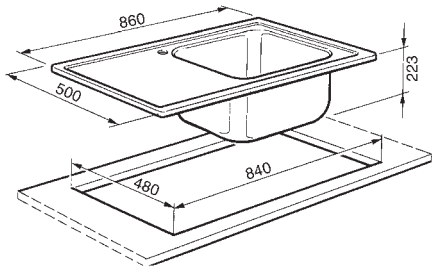
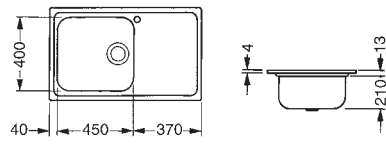

LG861D  
LG861S

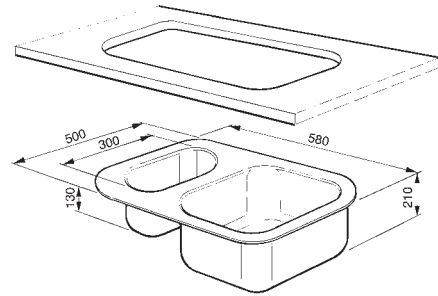
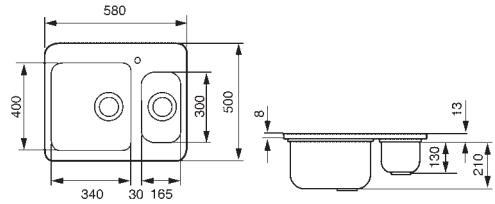

SRO3416

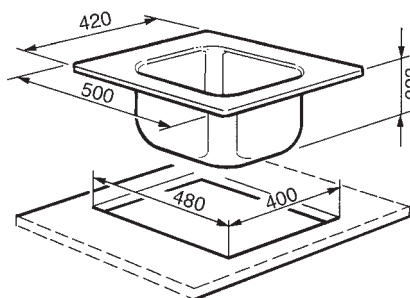
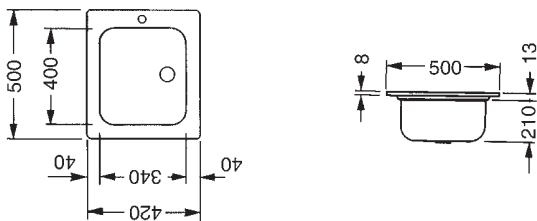

VS34/P3

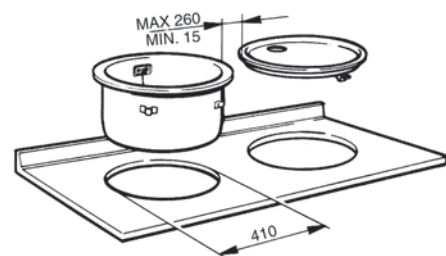
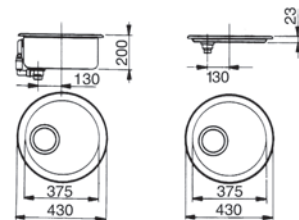

10I3P + 111

## UM4530

"ALBA" DOUBLE BOWL UNDERMOUNT SINK



Bowl depth: 180mm  
Bowl widths: 1 x 450mm, 1 x 300mm  
Drain: 3.5"

ALSO AVAILABLE IN THE FOLLOWING VERSION:

Bowl widths: 2 x 450mm **UM4545**  
Bowl depths: 2 x 180mm **UM4040**  
Bowl dimensions: LH bowl 400mm x 340mm  
RH bowl 400mm x 340mm

## UM4534

"ALBA" DOUBLE BOWL UNDERMOUNTED SINK COMBINATION



Bowl depths: 2 x 180mm  
Bowl dimensions: LH bowl 400mm x 450mm  
RH bowl 400mm x 340mm  
Drain: 3.5"

AVAILABLE IN THE FOLLOWING VERSIONS:

Bowl depths: 2 x 180mm **UM4540**  
Bowl dimensions: LH bowl 400mm x 450mm  
RH bowl 400mm x 400mm

## UM3416-1

"ALBA" 1.5 BOWL UNDERMOUNT SINK



Bowl depth: 180mm  
Bowl widths: 1 x 340mm, 1 x 165mm  
Drain: 3.5"

## UM30 + UM45

"ALBA" SINGLE BOWL UNDERMOUNT SINKS



Bowl depths: 180mm  
Bowl widths:  
UM45: 1 x 450mm  
UM30: 1 x 300mm  
Drain: 3.5"

ALSO AVAILABLE IN THE FOLLOWING VERSIONS:

Bowl width: 1 x 400mm **UM40**  
Bowl width: 1 x 165mm **UM16**

## ALBA UNDERMOUNT MODELS:

ALL SINKS ON THESE PAGES FEATURE THE ALBA DESIGN, AND DETAILS OF ALL THE VERSIONS AVAILABLE ARE SHOWN BELOW

Model	Drainer Position	Bowls	Minimum Base Unit (cm)
UM4545	N/A	2	90
UM4530	N/A	2	90
UM4540	N/A	2	90
UM4534	N/A	2	90
UM4040	N/A	2	90
UM3416-1	N/A	1,5	60
UM45	N/A	1	50
UM40	N/A	1	50
UM30	N/A	1	40
UM16	N/A	0,5	30

All sinks are supplied with overflows, drains, gaskets, fixing clips and dishwasher drain taps as standard accessories.

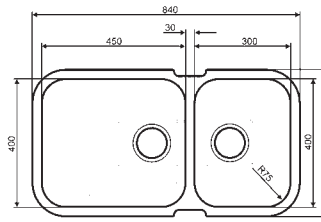
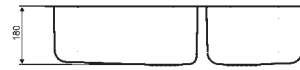

**UM4530**

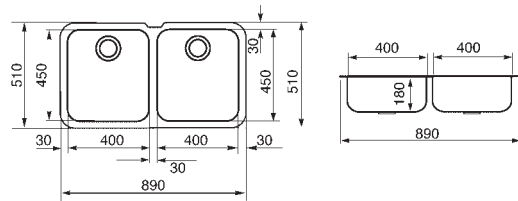

**UM4545**

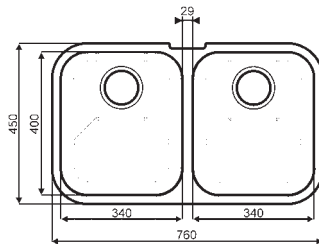
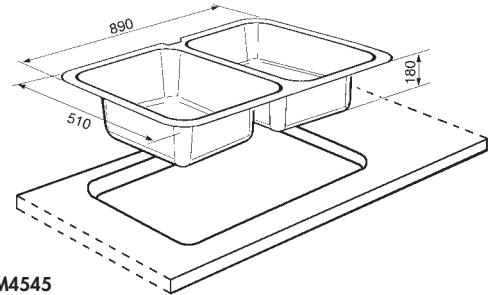

**UM4040**

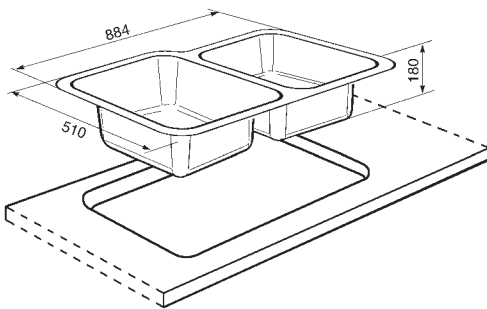

**UM4534**

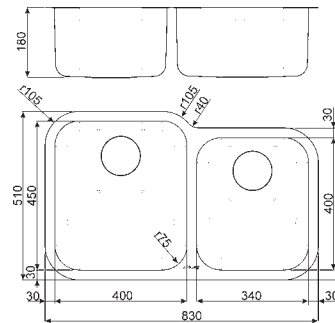

**UM4540**

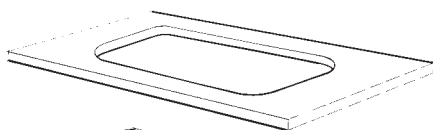
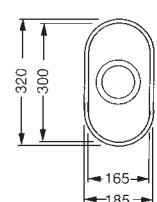
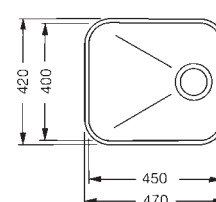
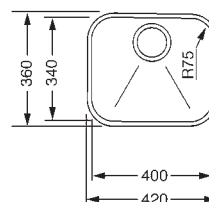
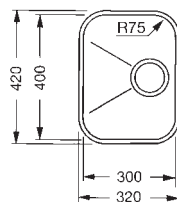

**UM3416-1**

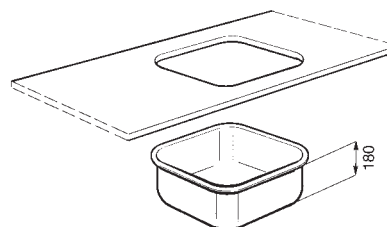
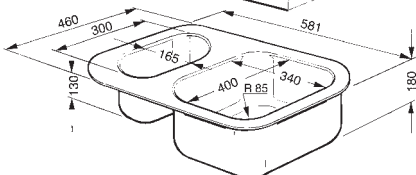

**UM30  
UM45  
UM40  
UM16**

## LE116D

"RIGAE" DOUBLE BOWL, SINGLE DRAINER INSET SINK



Bowl depth: 180mm  
Bowl widths: 2 x 340mm  
Drain: 3.5"

## LE862

"RIGAE" DOUBLE BOWL INSET SINK



Bowl depth: 180mm  
Bowl widths: 2 x 340mm  
Drain: 3.5"

## LE102D

"RIGAE" 1.5 BOWL, SINGLE DRAINER INSET SINK



Bowl depth: 180mm  
Bowl widths: 1 x 340mm, 1 x 165mm  
Drain: 3.5"

## LE861S

"RIGAE" SINGLE BOWL, SINGLE DRAINER INSET SINK



Bowl depth: 180mm  
Bowl width: 1 x 340mm  
Drain: 3.5"

## RIGAE INSET MODELS:

ALL SINKS ON THESE PAGES FEATURE THE RIGAE DESIGN, AND DETAILS OF ALL THE VERSIONS AVAILABLE ARE SHOWN BELOW

Model	Drainer Position	Bowls	Minimum Base Unit (cm)
LE116D	RH	2	90
LE116S	LH	2	90
LE862	N/A	2	90
LE102D	RH	1.5	60
LE102S	LH	1.5	60
LE861D	RH	1	45
LE861S	LH	1	45

All sinks are supplied with overflows, drains, gaskets, fixing clips and dishwasher drain taps as standard accessories.

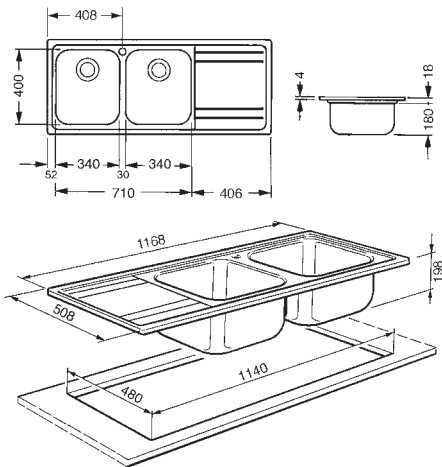

**LE116S**  
**LE116D**

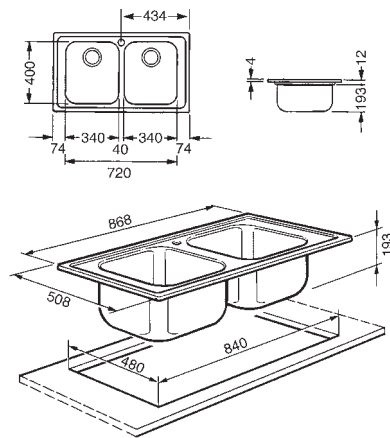

**LE862**

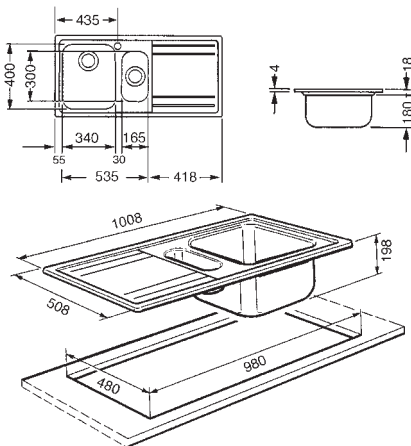

**LE102D**  
**LE102S**

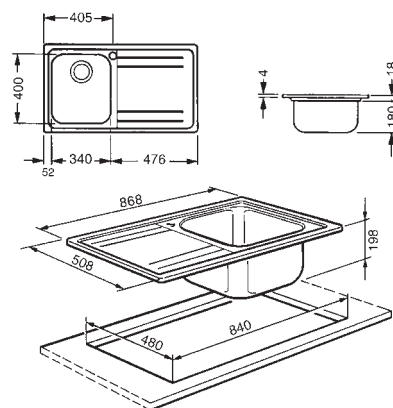

**LE861S**  
**LE861D**

## SINK & TAP ACCESSORIES

Sink style	MIRA	IRIS	ALBA	RIGAE
hardwood chopping board curved corners 450mm bowl width			CB45-1	
hardwood chopping board curved corners 340mm bowl width			CB34	CB34
hardwood chopping board curved corners 300mm bowl width			CB30	
hardwood chopping board round bowl			CB37C	
hardwood chopping board with white insert & st/steel colander			TLC34	TLC34
silver glass chopping board 24cm width	TVSG		TVSG	TVSG
black glass chopping board 24cm width	TVN		TVN	TVN
white glass chopping board 24cm width	TVB		TVB	TVB
st/steel drainer basket 450mm bowl width			DB45	
st/steel drainer basket 340mm bowl width	DB34		DB34	DB34
st/steel drainer basket 300mm bowl width			DB30	
st/steel drainer basket round bowl			DB37C	
large st/steel colander 340mm bowl width	COL34			
st/steel colander for oval half bowl	COL15	COL15	HBCOL	HBCOL

HARD-WOOD CHOPPING BOARD



HARDWOOD CHOPPING BOARD WITH WHITE INSERT AND COLANDER



NB: These boards are not suitable for use with undermounted sinks.

ST/STEEL DRAINER BASKET



ROUND DRAINER BASKET AND HARDWOOD CHOPPING BOARD



## TVSG

SILVER GLASS CHOPPING BOARD

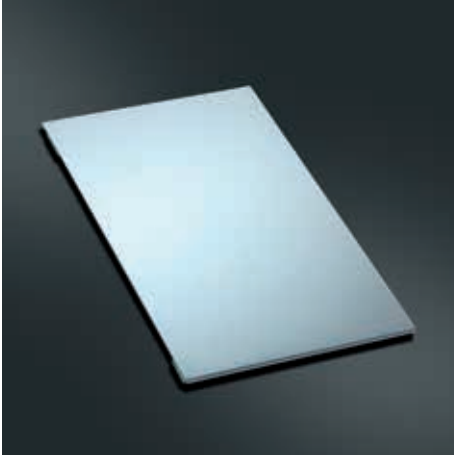

24cm width reversible stainless steel and glass chopping boards suitable for most Mira, Alba and Rigae sinks, and co-ordinate well with other Linea appliances in the kitchen.

## TVN

BLACK GLASS CHOPPING BOARD



## TVB

WHITE GLASS CHOPPING BOARD



## T12A-F

MULTI FIT CONNECTOR

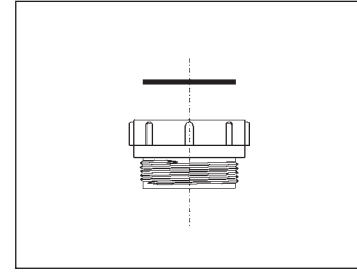

For use with a mixture of European and British plumbing parts - fits both sizes.

## STABMIX

TAP BRACE

Universal tap brace to add extra stability to tap and allow easy swivel movements between bowls.

LARGE COLANDER - MIRA



St/STEEL COLANDER - ALBA & RIGAE



St/STEEL COLANDER - MIRA & IRIS



## REDUCE REFUSE WITH A WASTE DISPOSAL UNIT



For those without the opportunity to compost food waste, the installation of a waste disposal unit in the kitchen sink helps to **keep food waste to a minimum** and maintain a clean and hygienic environment, removing the causes of unpleasant odours in the kitchen.

**KITGD50** waste disposal unit features include:

- continuous feed
- 1/2 horsepower motor
- fits all sinks with a 3 1/2" waste outlet

## ETNA3IN1

3 IN 1 INSTANT STEAMING WATER & STANDARD HOT & COLD TAP

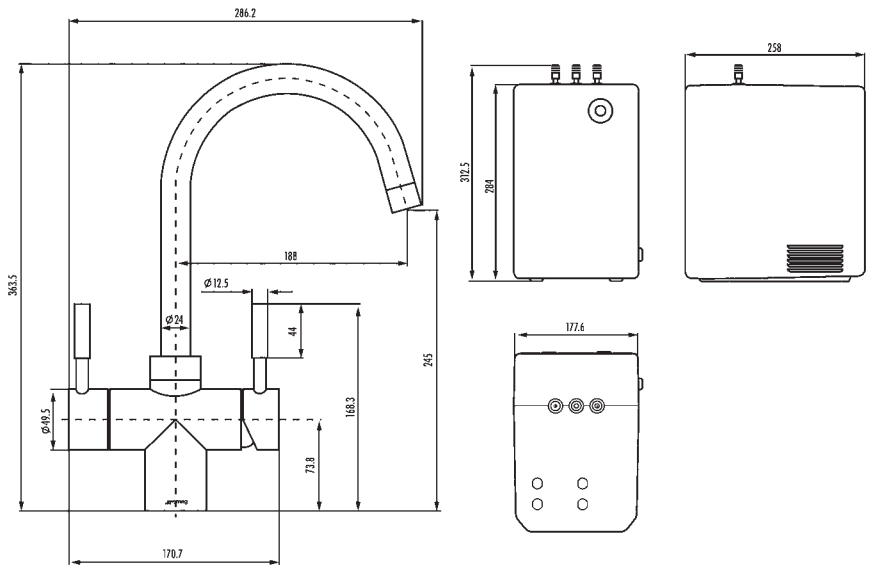

ETNA3IN1 Tap & feeder tank dimensions

- Chrome finish
- 3 in 1 instant steaming, hot & cold water mixer tap
- Swivel spout with anti-splash
- 2.5 litre water tank fits beneath sink
- DIY installation to non pressurised system
- Child safe handle mechanism on lever for 98°C water
- Eco friendly
- Braided stainless steel connection hoses
- Ceramic disc cartridge
- Minimum water pressure 0.5 bar

## KETTLE & KITCHEN TAPS REPLACED WITH A SINGLE UNIT

The ETNA3IN1 solution provides instant steaming water plus standard hot & cold supply, all in one neat and convenient tap. The tap does not connect to a pressurised water system meaning that it can be installed easily and the small tank fits into the cupboard beneath the sink.

### HOW IT WORKS

- 1** 98°C near-boiling water from Smeg tank
- 2** Hot water from mains
- 3** Cold water from mains

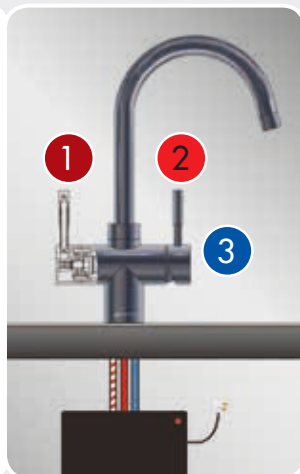

Near boiling water is available instantly - just release the safety mechanism and use the left hand tap lever as usual to release the water straight into the vessel of your choice. The right hand lever works exactly as a standard single lever tap for normal hot and cold water supplies as required.



## UKPARMA

SINGLE LEVER MIXER



Chrome finish  
Single lever mixer with square spout  
Swivel spout  
Aerator  
Ceramic disc cartridge  
Braided stainless steel connection hoses  
Minimum water pressure 0.5 bar

## IMOLA

WATER SAVING

SINGLE LEVER MIXER



Chrome finish  
Single lever mixer with flat spout  
Swivel spout  
Aerator  
Ceramic disc cartridge  
Braided stainless steel connection hoses  
Minimum water pressure 0.5 bar

Now with water saving cartridge

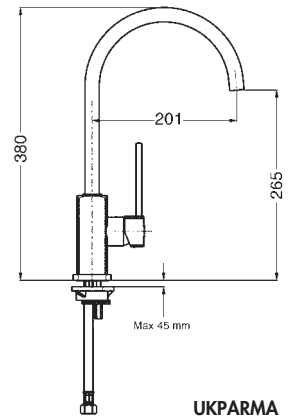

UKPARMA

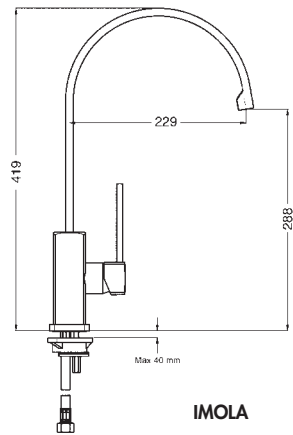

IMOLA

## PISA-BN

TRADITIONAL MIXER



Brushed nickel finish  
Dual flow mixer tap  
Swivel spout with anti-splash  
Quarter turn ceramic disc valve  
Copper connection tails  
Minimum water pressure 0.5 bar

ALSO AVAILABLE:  
Chrome finish

PISA-C

## MODENA

TRADITIONAL MIXER



Chrome finish  
Dual flow mixer tap  
Swivel spout with anti-splash  
Ceramic disc cartridge  
Braided stainless steel connection hoses  
Minimum water pressure 0.5 bar

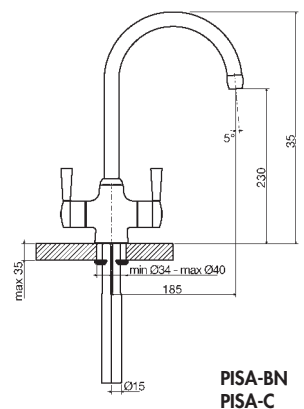

PISA-BN  
PISA-C

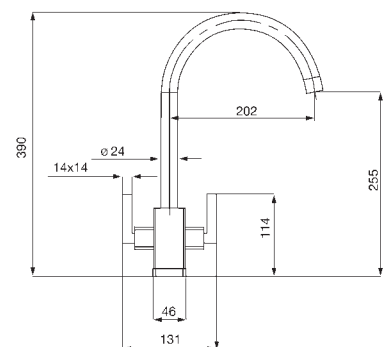

MODENA

## SIENA

SINGLE LEVER MIXER



Brushed stainless steel  
Single lever mixer in modern design  
Swivel spout  
Aerator  
Ceramic disc cartridge  
Braided stainless steel connection hoses  
Minimum water pressure 0.5 bar

## GENOA

SINGLE LEVER MIXER



Chrome finish  
Single lever mixer with black 'joystick' control  
Swivel spout  
Aerator  
Ceramic disc cartridge  
Braided stainless steel connection hoses  
Minimum water pressure 0.5 bar

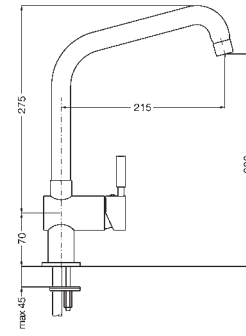

SIENA

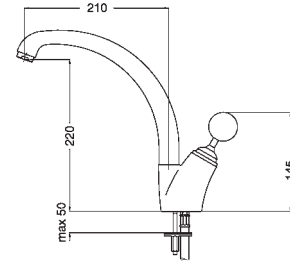

GENOA

## MF11CR2

SINGLE LEVER MIXER



Chrome finish  
Single lever mixer with curved neck  
Swivel spout  
Aerator  
Ceramic disc cartridge  
Braided stainless steel connection hoses  
Minimum water pressure 0.5 bar

## ROMA

SINGLE LEVER TAP WITH PULL OUT SPRAY



Chrome finish  
Single lever mixer  
Pull out spray  
Aerator  
Ceramic disc cartridge  
Braided stainless steel connection hoses  
Minimum water pressure 1 bar

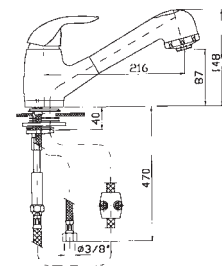

ROMA

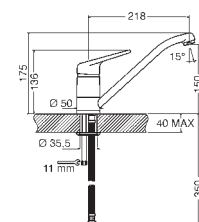

MF11CR2

## LINEA OVENS

Model No	SFP140	SFP125	SFP109	SF109
Oven width	60cm	60cm	60cm	60cm
Oven NET capacity (litres)	72L	72L	72L	72L
No of functions	12	10	8	8
Cleaning system	Pyro	Pyro	Pyro	Vapor
Oven type	touch control	-	-	-
<b>Colour Options</b>				
Stainless steel	SFP140	SFP125	-	-
Black	-	SFP125N	SFP109N	SF109N
Silver glass	SFP140S	SFP125S	SFP109S	SF109S
White	-	-	SFP109B	-
<b>Oven Accessories:</b>				
Roasting/Grill pan (40mm deep)	2	2	•	•
Grill mesh	•	•	•	•
Chrome shelf	2	2	•	•
Rotisserie kit	-	•	-	-
Roof liner	•	•	•	•
Telescopic guides	GT1T-1	GT1P-1	-	-
Lights	2 x halogen	2 x halogen	1 x halogen	1 x halogen
<b>Optional Extras</b>				
1 level telescopic shelf (Total extraction)	Standard	GT1T-1	GT1T-1	GT1T-1
1 level telescopic shelf (Partial extraction)	GT1P-1	Standard	GT1P-1	GT1P-1
Pizza stone	PRTX	PRTX	PRTX	PRTX
Folding pizza shovel	PALPZ	PALPZ	PALPZ	PALPZ
Stay clean liners	-	-	-	PC681
<b>Technical Data</b>				
Nominal power	3.0kW	3.0kW	3.0kW	3.0kW
Conventional kWh	1.10	1.10	1.10	1.03
Forced air convection kWh	0.99	0.99	0.79	0.79

## 45CM REDUCED HEIGHT COMPACT OVENS & DRAWERS

Model No.	SC45MC2	SC45M2	SC45VC2	S45MCX2	S45MX2	S45VCX2
Design	LINEA	LINEA	LINEA	CLASSIC	CLASSIC	CLASSIC
Type	microwave combi oven	microwave with grill	steam combi oven	microwave combi oven	microwave with grill	steam combi oven
Oven width	60cm	60cm	60cm	60cm	60cm	60cm
Oven capacity (Net)	34L	34L	31L	34L	34L	31L
<b>Colour Options</b>						
Stainless Steel	SC45MC2	SC45M2	SC45VC2	S45MCX2	S45MX2	S45VCX2
Black	SC45MCNE2	SC45MNE2	-	-	-	-
Silver glass	SC45MCSG2	-	-	-	-	-
White	SC45MCB2	SC45MB2	-	-	-	-
No. of Functions	10	6	10	10	6	10
<b>Standard Accessories Main oven</b>						
Deep pan/tray	1 glass	-	1 st/st	1 glass	-	1 st/st
St/steel tray	-	-	•	-	-	•
Non stick crisper/pizza plate	-	•	-	-	•	-
Wire mesh grill insert or grill trivet	•	•	-	•	•	-
Chrome shelf	-	-	•	-	-	•
Lights	1 x std	1 x std	1 x std	1 x std	1 x std	1 x std
<b>Optional Extras</b>						
St/steel shelf divider strip	PR3845X	PR3845X	PR3845X	PR3845X	PR3845X	PR3845X
29cm H warming drawer in st/steel	CT29-2	CT29-2	CT29-2	CT29X	CT29X	CT29X
20.5cm H warming drawer in st/steel	-	-	-	CTSC21X	CTSC21X	CTSC21X
15cm H warming drawer in st/steel	CT15-2	CT15-2	CT15-2	CT15X	CT15X	CT15X
15cm H warming drawer in black	CT15NE-2	CT15NE-2	-	-	-	-
15cm H warming drawer in silver glass	CT15SG2	CT15SG2	-	-	-	-
15cm H warming drawer in white	CT15B-2	CT15B-2	-	-	-	-
<b>Technical data</b>						
Nominal power	3.40kW	3.40kW	3.20kW	3.40kW	3.30kW	3.20kW
Microwave output power	1.00kW	1.00kW	-	1.00kW	1.00kW	-
Grill power	1.50k/h	1.50kW	-	1.50kW	1.50kW	-

## CLASSIC OVENS

Model No	SFP390X	SF390X	SFP378X	SF372X	SF341GVX
Oven width	60cm	60cm	60cm	60cm	60cm
Oven NET capacity (litres)	72L	72L	72L	72L	63L
No. of Functions	10	11	8	9	8
Cleaning system	Pyro	Vapor	Pyro	Vapor	-
Oven type	single electric	single electric	single electric	single electric	single gas
<b>Oven Accessories included</b>					
Extra deep tray (40mm deep)	2	•	•	•	•
Enamelled tray (20mm deep)	-	•	•	-	•
Grill mesh	•	•	•	•	•
Chrome shelf	2	•	•	•	•
Roof liner	•	•	-	•	-
Rotisserie kit	•	-	-	-	•
Telescopic guides	GT1P-1	GT1P-1	GT1P-1	-	GT1P-1
Lights	2 x halogen	2 x halogen	1 halogen	1 std	1 std
<b>Optional Extras</b>					
Folding pizza shovel	PALPZ	PALPZ	PALPZ	PALPZ	PALPZ
Pizza stone	PRTX	PRTX	PRTX	PRTX	PRTX
1 level telescopic shelf (Total extraction)	GT1T-1	GT1T-1	GT1T-1	GT1T-1	GT1T-1
1 level telescopic shelf (Partial extraction)	Standard	Standard	Standard	GT1P-1	Standard
Stay clean liners	-	PC68	-	PC681	PC60
<b>Technical Data</b>					
Nominal power	3.0kW	3.0kW	3.0kW	3.0kW	1.9kW
Conventional kWh	1.10	1.03	1.10	1.09	N/A
Forced air convection kWh	0.99	0.79	0.89	0.89	N/A

## DOUBLE & EXTRA WIDE CLASSIC OVENS

Model No	DOSP38X	DOSC36X	DUSC36X	SFP3900X
Oven width	60cm	60cm	60cm	90cm
Oven NET capacity (litres)	72L & 36L	72L & 36L	63L & 36L	80L
No. of Functions	10 & 4	6 & 4	6 & 4	12
Cleaning system	Pyro in main oven	Stay clean liners	Stay clean liners	Pyro
Oven type	double electric	double electric	double electric	single electric extra wide
<b>Oven Accessories</b>				
Extra deep tray (40mm deep)	2	2	2	-
Roasting/Grill pan (20mm deep)	-	-	-	2
Grill mesh	2	2	2	1
Chrome shelf	3	2	2	2
Roof liner	-	•	•	•
Telescopic guides	•	-	-	•
Rotisserie kit	-	-	-	•
Lights	2 halogen	2 standard	2 standard	2 halogen
<b>Optional Extras</b>				
Folding pizza shovel	PALPZ	PALPZ	PALPZ	PALPZ
Pizza stone	PRTX	PRTX	PRTX	PRTX or PPR2
Telescopic guides (total extraction)	GT1T-1	GT1T-1	GT1T-1	Standard
Telescopic guides (partial extraction)	Standard	GT1P-1	GT1P-1	Standard
Stay clean liners	-	Standard	Standard	-
<b>Technical Data</b>				
Nominal power	5.6kW	5.6kW	5.5kW	3.1kW
Conventional kWh (main oven)	0.89	-	-	1.29
Forced air convection kWh (main oven)	0.79	0.89	0.79	1.19
Conventional kWh (auxiliary oven)	0.71	0.71	0.79	N/A

## PIANO DESIGN, MARC NEWSON & CORTINA DESIGNER OVENS

Further information for Smeg designer ovens can be found on [www.smeguk.com](http://www.smeguk.com).

## HIGH POWERED ELECTRIC HOBS

When selecting an appliance with a nominal power in excess of 7.2kW, a qualified electrician should be consulted to check the suitability of the circuit within the property where the connection is intended to be made. Recent wiring developments can allow larger high powered appliances to be installed safely in homes by experts. All such appliances must be installed by a qualified electrician.

## OPERA COOKERS

	A5	A4	A3	A2PY	A2	A1	A1PY
<b>Colour Options (Gas Hob)</b>							
Stainless Steel	A5-8	A4-8	A3-7		A2-8	A1-7	
Stainless Steel (pyrolytic cleaning)				A2PY-8			
Black		A4BL-8			A2BL-8	A1BL-7	
Cream						A1P-9	
<b>Colour Option (Induction Hob)</b>							
Stainless Steel (pyrolytic cleaning)				A2PYID-8			A1PYID-7
<b>Technical data</b>							
Main oven NET capacity (litres)	80L	63L	80L	63L	63L	80L	80L
Auxiliary oven NET capacity (litres)	58L	58L	41L	35L	35L		
Nominal power (Gas models)	7.7 kW	7.5 kW	6.8 kW	5.3kW	5.3kW	3.0kW	
Nominal power (Induction model)				14.7kW			12.6kW
Conventional kWh (main oven)	1.21	0.91	1.21	0.99	0.89	1.13	1.29
Conventional kWh (auxiliary oven)	0.85	0.84	0.79	0.79	0.79		
Forced air convection kWh (main oven)	0.99	0.79	0.99	0.89	0.79	0.99	1.19
Forced air convection kWh (auxiliary oven)	0.79	0.79					
<b>Standard Accessories Main oven</b>							
Roasting/Grill pan	•	•	•	•	•	•	•
Grill Mesh	•	•		•	•	•	•
Chrome Shelf	2	•	2	•	•	2	2
Non-Stick tray	•		•			•	•
Rotisserie kit	•	•	•			•	•
Roof Liner		•		•	•		
Enamelled tray		•			•		
Wok Support			•			•	
Stay clean liners	•	•	•		•	•	
<b>Standard Accessories Auxiliary oven</b>							
Roasting/Grill pan	•	•	•	•	•		
Grill Pan Handle				•	•		
Grill Mesh	•	•	•	•	•		
Chrome Shelf	•	•	•	•	•		
Rotisserie kit				•	•		
Pizza Stone	•	•					
Pizza Shovel	•	•					
Roof Liner	•	•		•	•		
Stay clean liners	•	•					
<b>Optional Extras</b>							
Splashback (Stainless steel)	KIT1A5-5	KIT1A3-6	KIT1A3-6	KIT1CSP20	KIT1A2-6	KIT1A1-6	KIT1CSP19
Splashback (Polished St/steel - to match black models)					KIT1A2SE6	KIT1A1SE6	
Chimney hood (Stainless steel)	KD150X-2	KD120X-2	KD120X-2	KD100X-2	KD100X-2	KD90X-2	KD90X-2
Chimney hood (Gloss black)					KD100N-2	KD90N-2	
Chimney hood (Cream)						KSED95P9	
Telescopic shelf set (Total extraction)	GT1T-1	GT1T-1	GTA-6	GT1T-1	GT1T-1	GTA-6	GTA-6
Telescopic shelf set (Partial extraction)	GT1P-1	GT1P-1		GT1P-1	GT1P-1		
Plate rack (auxiliary oven)			PR9A3	PR7A2	PR7A2		
Wok Support (Gas Model)	WOKGHU	WOKGHU	WOKGHU	WOKGHU	WOKGHU	WOKGHU	
Teppanyaki grill plate (gas hobs)	TPKX	TPKX	TPKX	TPKX	TPKX	TPKX	
Cast iron open griddle	GO120	GO120	GO120				
Cast iron ribbed griddle	GC120	GC120	GC120				
Pizza stone	PRTX	PRTX	PRTX	PRTX	PRTX	PRTX	PRTX
Pizza shovel	PALPZ	PALPZ	PALPZ	PALPZ	PALPZ	PALPZ	PALPZ

## VICTORIA & SYMPHONY COOKERS

	TR4110	TR93	SY4110	SY92IP	SY92PX8	SY62MX8	SY6CPX8
<b>Design</b>	VICTORIA		SYMPHONY		SYMPHONY	SYMPHONY	SYMPHONY
<b>Colour Options (Gas Hob)</b>							
Stainless Steel			SY4110-8			SY62MX8	
Stainless Steel (pyrolytic cleaning)					SY92PX8		
Black	TR4110BL1	TR93BL	SY4110BL8				
Cream	TR4110P1	TR93P					
Pastel blue	TR4110AZ						
Pink	TR4110RO						
Red Wine	TR4110RWF						
Silver	TR4110SF						
<b>Colour Option (Electric/Induction Hob)</b>							
Stainless Steel (pyrolytic cleaning)				SY92IPX8			SY6CPX8
Black (pyrolytic cleaning)				SY92IPBL8			
<b>Technical data</b>							
Main oven NET capacity (litres)	63L	63L	63L	72L	72L	63L	72L
Auxiliary oven NET capacity (litres)	63L	65L	63L	35L	35L	36L	
Grill compartment	35L	36L	35L				
Nominal power kW	8.7	8,5	8.7	15.8	5.2	5.4	10.4
Conventional kWh (main oven)	0.90	0.83	0.89	0.89	0.89	0.88	0.99
Forced air convection kWh (main oven)	0.79	0.79	0.79	0.96	0.96	0.79	1.01
Conventional kWh (auxiliary oven)	0.83		0.82	0.71	0.71	0.71	
Forced air convection kWh (auxiliary oven)	0.79	0.89	0.79				
<b>Standard Accessories Main oven</b>							
Roasting/Grill pan	2	•	2	2	2	2	2
Grill Mesh	•	•	•	•	•	•	•
Chrome Shelf	2	•	2	•	•	•	2
Telescopic shelf	2 x GT1P-1	GT1P-1	2 x GT1P-1	GTIP-1	GTIP-1	GTIP-1	GTIP-1
Rotisserie kit			•	•		•	GTIP
Roof Liner	•		•	•	•	•	•
<b>Standard Accessories Auxiliary oven</b>							
Roasting/Grill pan (20mm deep)	•		•	•	•	•	
Grill Mesh	•		•	•	•	•	
Chrome Shelf	•	4	•	•	•	•	
Roof Liner			•			•	
<b>Cooker base &amp; height</b>							
Fixed plinth at base (H= 900mm)	•	•	•			•	
4 St/steel legs (H= 880-915mm) or optional plinth (H= 900mm)				•	•		•
<b>Optional Extras</b>							
Splashback (Stainless steel)			KITS110X8	KITC9X	KITC9X	KITC6X	KITC6X
Splashback (Cream)	SPG110P	SPG9075P					
Splashback (Black)	SPG110NE	SPG9075NE					
Chimney hood (Stainless steel)			KSE110X	KFV92D-2	KFV92D-2	KFV62D-2	KFV62D-2
Chimney hood (Cream)	KT110P	KT90P					
Chimney hood (Gloss black)	KT110BL	KT90BL	KSE110BL				
Teppanyaki grill plate	TPKTR	TPKTR	TBX6090		TBX6090	TBX6090	
Telescopic shelf set (Total extraction)	GT1T-1	GT1T-1	GT1T-1	GT1T-1	GT1T-1	GT1T-1	GT1T-1
Telescopic shelf set (Partial extraction)	standard	standard	standard	standard	standard	standard	standard
Plate rack (auxiliary oven)				PR7A2	PR7A2		
Wok Support	WOKGHU	WOKGHU	WOKGHU		WOKGHU	WOKGHU	
Stay clean liners (Main)			PC60			PC60	
Pizza stone	PRTX	PRTX	PRTX	PRTX	PRTX	PRTX	PRTX
Pizza shovel	PALPZ	PALPZ	PALPZ	PALPZ	PALPZ	PALPZ	PALPZ

## HIGH POWERED COOKERS

When selecting an appliance with a nominal power in excess of 7.2kW, a qualified electrician should be consulted to check the suitability of the circuit within the property where the connection is intended to be made. Recent wiring developments can allow larger high powered appliances to be installed safely in homes by experts. All such appliances must be installed by a qualified electrician.

## CONCERT COOKERS

	SUK92	SUK62	SUK61	SUK61
<b>Colour Options (Gas Hob)</b>				
Stainless Steel	SUK92MX9	SUK62MX8		SUK61MX8
Stainless Steel (pyrolytic cleaning)			SUK61PX8	
Black	SUK92MBL9	SUK62MBL8		SUK61MBL8
Cream	SUK92P9-1			
<b>Colour Option (Ceramic Hob)</b>				
Stainless Steel	SUK92CMX9	SUK62CMX8		
Black	SUK92CBL9	SUK62CBL8		
<b>Technical data</b>				
Main oven net capacity (litres)	72L	68L	72L	72L
Auxiliary oven net capacity (litres)	35L	36L		
Nominal power (Gas hob)	4.3kW	5.4kW	3.0kW	3.0kW
Nominal power (ceramic hob)	13.3kW	12.8kW		
Conventional kWh (main oven)	0.92		0.99	0.94
Conventional kWh (auxiliary oven)	0.71	0.71		
Forced air convection kWh (main oven)	0.89	0.69	1.01	0.89
<b>Standard Accessories Main oven</b>				
Roasting/Grill pan	2		2	
Grill Mesh	•	•	•	•
Chrome Shelf	•	•	•	•
Roof Liner	•			
Wok Support (gas hob models only)	•	•	•	•
<b>Standard Accessories Auxiliary oven</b>				
Grill Mesh	•	•		
Chrome Shelf	•	•		
Non-Stick tray	•	•		
Roof Liner		•		
<b>Cooker base &amp; height</b>				
Fixed plinth at base (cooker height 900mm)		•		
4 St/steel legs (cooker height 880-915mm) or optional plinth (cooker height 900mm)	•		•	•
<b>Optional Extras</b>				
Splashback (Stainless steel)	KIT90X	KIT60X	KIT60PX	KIT60X
Chimney hood (Stainless steel)	KSED95X-1	KSED65X-1	KSED65X-1	KSED65X-1
Chimney hood (Cream)	KSED95P9			
Teppanyaki grill plate (gas models only)	TBX6090	TBX6090	TBX6090	TBX6090
1 level telescopic shelf (total extraction)	GTIT-1	GTIT-1	GTIT-1	GTIT-1
2 level telescopic shelf (partial extraction)	GT1P-1	GT1P-1	GT1P-1	GT1P-1
Plate rack (auxiliary oven)	PR7A2			
Wok Support (gas models only)	WOKGHU	WOKGHU	WOKGHU	WOKGHU
Stay clean liners (Main)	PC60	PC60		PC68
Pizza stone	PRTX	PRTX	PRTX	PRTX
Pizza shovel	PALPZ	PALPZ	PALPZ	PALPZ

## HIGH POWERED COOKERS

When selecting an appliance with a nominal power in excess of 7.2kW, a qualified electrician should be consulted to check the suitability of the circuit within the property where the connection is intended to be made. Recent wiring developments can allow larger high powered appliances to be installed safely in homes by experts. All such appliances must be installed by a qualified electrician.

## COOKER SELECTION AT A GLANCE

Cooker width	Model no	FINISH								HOB TYPE			NO. OF OVENS			MAIN OVEN
		stainless steel	gloss black	gloss cream	pastel blue	pink	red wine	silver	gas	induction	ceramic	1	2	3	pyrolytic cleaning	
<b>OPERA RANGE</b>																
150cm	A5-8	•							•				•			
120cm	A4-8	•							•				•			
	A4BL-8		•						•				•			
	A3-7	•							•				•			
100cm	A2PYID-8	•							•	•			•			•
	A2PY-8	•							•				•			•
	A2-8	•							•				•			
	A2BL-8		•						•				•			
90cm	A1PYID-7	•							•	•			•			•
	A1-7	•							•				•			
	A1BL-7		•						•				•			
	A1P-9			•					•				•			
<b>VICTORIA RANGE</b>																
110cm	TR4110P1			•					•							•
	TR4110BL1		•						•							•
	TR4110AZ				•				•							
	TR4110RO					•			•							
	TR4110RWF						•		•							
	TR4110SF							•	•							
	TR93P			•					•							•
	TR93BL		•						•							•
<b>SYMPHONY RANGE</b>																
110cm	SY4110-8	•							•							•
	SY4110BL8		•						•							•
90cm	SY92IPX8	•							•	•			•			•
	SY92IPBL8		•						•	•			•			•
	SY92PX8	•							•				•			•
60cm	SY62MX8	•							•				•			•
	SY6CPX8	•							•		•	•				•
	SY92PX8	•							•				•			•
<b>CONCERT RANGE</b>																
90cm	SUK92MX9	•							•				•			•
	SUK92MBL9		•						•				•			•
	SUK92P9-1			•					•				•			•
	SUK92CMX9	•							•		•		•			•
	SUK92CBL9		•						•		•		•			•
60cm	SUK62MX8	•							•				•			•
	SUK62MBL8		•						•				•			•
	SUK62CMX8	•							•		•		•			•
	SUK62CBL8		•						•		•		•			•
	SUK61PX8	•							•				•			•
	SUK61MX8	•							•				•			•
	SUK61MBL8		•						•				•			•

## GLASS SPLASHBACKS

## UPSTANDS

DIMENSIONS	60cm W x 75cm H	75cm W x 75cm H	75cm W x 32cm H	90cm W x 75cm H	110cm W x 75cm H	2 x 100cm W x 14cm H
GLASS COLOUR	MODELS NOS	MODELS NOS	MODELS NOS	MODELS NOS	MODELS NOS	MODELS NOS
BLACK	SPG6075NE	SPG7575NE	SPG7532NE	SPG9075NE	SPG110NE	UPGNE
CREAM	SPG6075P			SPG9075P	SPG110P	UPGP
RED	SPG6075R			SPG9075R		UPGR
PASTEL BLUE	SPG6075AZ			SPG9075AZ		UPGAZ
LIME	SPG6075VE			SPG9075VE		UPGVE
SILVER	SPG6075S	SPG7575S		SPG9075S		UPGS
MATT WHITE	SMG6075B	SMG7575B	SMG7532B	SMG9075B		UMGB
MATT BLACK	SMG6075NE	SMG7575NE	SMG7532NE	SMG9075NE		UMGNE

# HOODS

Model No	Hood type	MODEL DETAILS				OPTIONAL EXTRAS/ACCESSORIES			
		Colour	Hood width	Vent outlet diameter	Nominal power	Filter or re-circulation kit	Charcoal Filter	Simple vent kit	Comprehensive vent kit
KD150X-2	chimney	st/steel	150cm	150mm	500W		FLTК-1 x 2	SP150	SP150FLAT
KD120X-2	chimney	st/steel	120cm	150mm	205W		FLTК-1	SP150	SP150FLAT
KI120X-1	island	st/steel	120cm	150mm	330W		KITFC161	N/A	SP150FLAT
KT110BL	chimney	black	110cm	150mm	250W		FLT6	SP150	SP150FLAT
KT110P	chimney	cream	110cm	150mm	250W		FLT6	SP150	SP150FLAT
KT90P	chimney	cream	90cm	150mm	210W		FLT6	SP150	SP150FLAT
KT90BL	chimney	black	90cm	150mm	210W		FLT6	SP150	SP150FLAT
KSE110BL	chimney	black	110cm	150mm	290W		FLT3	SP150	SP150FLAT
KSE110X	chimney	st/steel	110cm	150mm	290W		FLT3	SP150	SP150FLAT
KSE110P-9	chimney	cream	110cm	150mm	290W		FLT3	SP150	SP150FLAT
KD100N-2	chimney	black & st/st	100cm	150mm	205W		FLTК-1	SP150	SP150FLAT
KD100X-2	chimney	st/steel	100cm	150mm	205W		FLTК-1	SP150	SP150FLAT
KDD90VX	downdraft	st/steel and black glass	90cm	150cm	275W		KITFC161	SP150	SP150FLAT
KD90N-2	chimney	black & st/st	90cm	150mm	205W		FLTК-1	SP150	SP150FLAT
KD90X-2	chimney	st/steel	90cm	150mm	205W		FLTК-1	SP150	SP150FLAT
KSE912X3	chimney	st/st & silver glass facia	90cm	150mm	380W		KITFC161	SP150	SP150FLAT
KSE912NX3	chimney	st/st & black glass facia	90cm	150mm	380W		KITFC161	SP150	SP150FLAT
KCVB9B	angled	st/st & white glass	90cm	150mm	450W	KITFTS	KITFC906	SP150	SP150FLAT
KCVR9NE	angled	st/st & black glass	90cm	150mm	450W	KITFTS	KITFC906	SP150	SP150FLAT
KFV92D-2	chimney	st/st & clear glass	90cm	150mm	290W		KITFC161	SP150	SP150FLAT
KFV92DN-2	chimney	st/st & black glass	90cm	150mm	290W		KITFC161	SP150	SP150FLAT
KSED95P-9	chimney	cream	90cm	120mm	240W		FLT2	SP215	SP217
KSED95X-1	chimney	st/steel	90cm	120mm	240W		FLT2	SP215	SP217
KEIV90	island	st/st & clear glass	90cm	150mm	220W		KITFC900	N/A	SP150FLAT
KSET910X	telescopic	st/steel	90cm	120mm	300W		KITC3R	SP215	SP217
KSEG90X-1	ceiling	st/steel	90cm	150mm	380W		KITFC152	SP150	SP150FLAT
KSEG77X-1	canopy or ceiling	st/steel	77cm	150mm	290W		KITFC161	SP150	SP150FLAT
KTS75AC-1	angled	st/st & graphite glass	75cm	150mm	240W	KITFTS	KITFC906	SP150	SP150FLAT
KTS75C	angled	st/st & silver glass	75cm	150mm	240W	KITFTS	KITFC906	SP150	SP150FLAT
KTS75NC	angled	st/st & black glass	75cm	150mm	240W	KITFTS	KITFC906	SP150	SP150FLAT
KMN75X	angled	st/steel	75cm	150mm	380W		KITFC152	SP150	SP150FLAT
KMN75AN	angled	matt black glass & st/steel	75cm	150mm	380W		KITFC152	SP150	SP150FLAT
KMN75AB	angled	matt white glass & st/steel	75cm	150mm	380W		KITFC152	SP150	SP150FLAT
KSED75X-1	chimney	st/steel	70cm	120mm	240W		FLT2	SP215	SP217
KSEG7-1	canopy	silver grey	70cm	120mm	181W		KITFC155	SP150	SP150FLAT
KFV62D-2	chimney	st/st & clear glass	60cm	150mm	290W		KITFC161	SP150	SP150FLAT
KFV62DN-2	chimney	st/st & black glass	60cm	150mm	290W		KITFC161	SP150	SP150FLAT
KFV62DB	chimney	st/st & white glass	60cm	150mm	290W		KITFC161	SP150	SP150FLAT
KSED65X-1	chimney	st/steel	60cm	120mm	240W		FLT2	SP215	SP217
KSET610X	telescopic	st/steel	60cm	120mm	280W		KITC3R	SP215	SP217
KSEG54X-1	canopy or ceiling	st/steel	54cm	150mm	290W		KITFC161	SP150	SP150FLAT

## Vent kits

Simple vent kits include 1 metre of flexible hose, while comprehensive kits add a further 2 metres of ducting with two 1 metre flat channel sections.

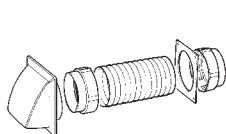

SP150

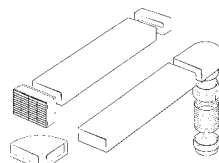

SP150FLAT

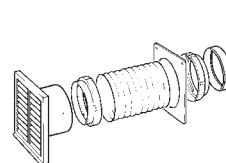

SP215

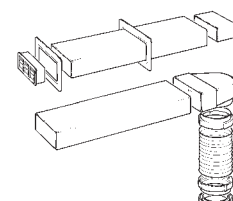

SP217

# REFRIGERATION

	Energy efficiency class	Energy consumption (Kw/h per year)	Climatic class	Freezing capacity (kg/24h)	Thaw time (h)	Reversible doors (Y/N)	Comprehensive door storage (Y/N)	Sliding rail or door-on-door fitting
<b>Freestanding models</b>								
FAB50	A+	419	SN-T	5	8	N	Y	N/A
FAB32 (no frost)	A++	229	SN, N, ST, T	10	18	N	Y	N/A
FAB32 (fanned)	A++	229	SN, N, ST, T	4	21	N	Y	N/A
FAB30	A++	212	SN-T	3	15	N	Y	N/A
FAB28	A++	180	N-ST	2	12	N	Y	N/A
CVB20	A+	223	SN-ST	20	23	N	N	N/A
FAB10	A+	169	SN	2	10	N	Y	N/A
FAB10H	A+	123	SN-T	N/A	N/A	N	Y	N/A
FAB5 (absorption)	E	278	SN, N, T	-	-	N	Y	N/A
FQ60XP	A+	455	SN, T	13	15	N	Y	N/A
FQ55FX	A+	458	SN, T	5	22	N	Y	N/A
FA55PCIL3	A+	461	N-T	12	5	N	Y	N/A
FA55XBIL3	A+	461	N-T	12	5	N	Y	N/A
FC34XPNF	A+	307	N	6	17	Y	Y	N/A
UK26PXNF3	A+	323	N-T	14	9	Y	N	N/A
UK35PX3	A+	150	N-T	N/A	N/A	Y	Y	N/A
<b>Built-in models</b>								
CR330AP	A+	274	ST	6	13	Y	Y	SR
CR325PNFZ	A+	312	SN-T	9	16	Y	Y	SR
CB30PFNF	A+	298	N-T	10	12	Y	Y	DD
FR310P	A+	296	SN-T	3	14	Y	Y	SR
VI205PNF	A+	305	SN-T	10	8	Y	N	SR
FR320P	A+	146	N-T	N/A	N/A	Y	Y	SR
FR2052P1	A++	178	SN-T	2	12	Y	Y	SR
FR2202P1	A++	104	SN-T	N/A	N/A	Y	Y	SR
VI05AP1	A+	177	SN,N,ST,T	6	15	Y	N	SR

## Climatic Class

The climatic class indicates the range of ambient temperatures for which the appliance is suitable. It is important to select a refrigeration appliance specified for the environment in which it is to be situated.

Climatic Class	Min temp (°C)	Max temp (°C)
SN	10	32
N	16	32
ST	18	38
T	18	43

## FREESTANDING DISHWASHERS

60cm models	DF13SS	DC134	DC122	DF6FAB1	DF6FAB2
<b>Type &amp; Colour</b>					
Fully clad st/steel	•				
Door st/steel		DC134LSS	DC122SS-1		
Black		DC134LB	DC122B-1		
White		DC134LW	DC122W-1		
Coloured Retro				•	•
<b>Technical data</b>					
International place settings	13	13	12	13	13
Noise level dB(A) re 1pW	39	43	49	42	43
Energy efficiency rating	A+++	A+	A+	A++	A+
Drying performance	A	A	A	A	A
EN50242 test programme	Eco	Eco	Eco	Eco	Eco
Nominal power (kW)	1.9	1.9	1.9	1.9	1.9
Water consumption (litres per annum)	2520	2744	3360	2800	2744
Energy consumption (kW/year)	230	292	286	258	292
<b>Features</b>					
Aquastop	Total	Total	Partial	Total	Total
Condenser drying	•	•	•	•	•
Concealed heating element	•	•	•	•	•
Adjustable water softener	•	•	•	•	•
FlexiDuo	•	•			•
Adjustable lower basket	Total	Total		2 Racks	2 Racks
Automatic adjustable upper basket	3 Levels	3 Levels		3 Levels	3 Levels
Manual upper basket			2 levels		
Easyglide baskets	•	•		•	•
Self balancing door hinges	•	•	•	•	•
St/steel filter	•	•	•	•	•
Delay timer	1-24h	1-24h	3,6,9,12h	1-9h	1-9h

45cm models	DF4SS-1	D4
<b>Type &amp; Colour</b>		
Fully clad st/steel	•	D4SS-1
Black		D4B-1
<b>Technical data</b>		
International place settings	10	10
Noise level dB(A) re 1pW	46	46
Energy efficiency rating	A+	A+
Drying performance	A	A
EN50242 test programme	Eco	Eco
Nominal power (kW)	1,9	1,9
Water consumption (litres per annum)	2600	2600
Energy consumption (kW/year)	236	236
<b>Features</b>		
Aquastop	Total	Total
Condenser drying	•	
Concealed heating element	•	•
Adjustable water softener	•	•
Adjustable lower basket	•	•
Automatic adjustable upper basket	3 levels	3 levels
Grey baskets	•	•
Self balancing door hinges	•	•
St/steel filter	•	•
Delay timer	24h	24h

## BUILT-IN DISHWASHERS

Horizontal & 60cm models	DI6FAB1	DI6FAB2	DI6SS-1	DI6MAX-1	DI6013NH-1	DI6013-1	DI6012-1
<b>Type &amp; Colour</b>							
Product width	60cm	60cm	60cm	60cm	60cm	60cm	60cm
Coloured Retro	•	•					
Fully integrated				•	•	•	•
St/steel door			•				
<b>Technical data</b>							
International place settings	13	13	13	13	13	13	12
Noise level dB(A) re 1pV	43	43	39	44	44	44	48
Energy efficiency rating	A++	A+	A+++	A+++	A+++	A+++	A+
Drying performance	A	A	A	A	A	A	A
EN50242 test programme	Bio	Eco	Eco	Eco	Eco	Eco	Eco
Nominal power (kW)	1,9	1,9	1,9	1,9	1,9	1,9	1,9
Water consumption (litres per annum)	2800	2744	2520	2520	2520	2520	3360
Energy consumption (kW/year)	258	292	230	230	230	230	286
<b>Features</b>							
Aquastop	Total	Total	Total	Total	Total	Total	Partial
Condenser drying	•	•	•	•	•	•	•
Active Light			•	•	•	•	
Concealed heating element	•	•	•	•	•	•	•
Adjustable water softener	•	•	•	•	•	•	•
FlexiDuo		•	•	•	•	•	
Adjustable lower basket	2 Racks	2 Racks	Total	2 Racks	2 Racks	2 Racks	
Automatic adjustable upper basket	3 Levels	3 Levels	3 Levels	3 Levels	3 Levels	3 Level	
Manual upper basket							2 Levels
Easyglide baskets	•	•	•				
Easy multi-hinge door assembly				•	•	•	
Self balancing door hinges	•	•	•	•	•	•	•
St/steel filter	•	•	•	•	•	•	•
Delay timer	1-9h	1-9h	1-24h	1-24h	1-24h	1-24h	

45cm models	DI4-1
<b>Type &amp; Colour</b>	
Fully integrated	•
St/steel door	
<b>Technical data</b>	
International place settings	10
Noise level dB(A) re 1pV	46
Energy efficiency rating	A+
Washing performance	A
Drying performance	A
EN50242 test programme	Eco
Nominal power (kW)	1,9
Water consumption (litres)	2660
Energy consumption (kWh)	236
<b>Features</b>	
Aquastop	Total
Concealed heating element	•
Adjustable water softener	•
Adjustable lower basket	•
Adjustable upper basket	•
Easy glide St/steel baskets	•
Self balancing door hinges	•
St/steel filter	•
Delay timer	1-24h

## Quality, Environmental and Occupational Health & Safety Management Systems

All Smeg factories are ISO9001, ISO14001 and OHSAS 18001 certified, ensuring that the highest standards of quality are continually maintained whilst actively responding to all environmental issues relating to manufacture. The materials and components used to produce smeg products undergo strict quality control testing, and care is taken to source recyclable materials wherever possible. These management systems enable Smeg to provide complete assurance that all products meet superior standards whilst respecting the environment. The workforce is not forgotten – the occupational health and safety assessment scheme promotes a safe and healthy working environment, aids legislative compliance and helps improve overall performance.



UNI EN ISO 9001



UNI EN ISO 14001



OHSAS 18001

## SYMBOLS GUIDE

### GENERAL

**B A A+ A++ A+++** Product **energy rating**, measured from A+++ to D / G depending on the product family.

**A -10% A -20%** Appliances with this symbol can reduce energy consumption by a further 10% - 20% from the standard A energy rating.

 **Finger-friendly stainless steel** finish keeps stainless steel looking as good as new.

 Easy to use **touch controls** allow the appliance to be programmed at the touch of a button.

 **Child lock**, some models are fitted with a device to lock the programme/cycle so it cannot be accidentally changed.

 **Illuminated controls** are a safety device to alert the user that the appliance is on as well as being a stunning design feature.

 **Eco-logic** option allows you to restrict the power limit of the appliance real energy saving.

### OVENS & COOKERS

**36 lt 63 lt 72 lt 80 lt** The **capacity** indicates the amount of usable space in the oven cavity in litres.

 Smeg ovens incorporate **safe cook**, the system for closed door grilling to keep cooking smells inside the oven and ensure a safe cooking environment.

 The **rapid preheat** function can be used to reach the selected temperature in just a few minutes.

 All Pyrolytic ovens have a **cooler touch door** which allows the outer glass door to become no hotter than 55°C.

**2 3 4 5** Figure shows the number of **different cooking levels**, 4 or 5 for full sized ovens and 2 or 3 for auxiliary ovens.

 **Telescopic rails** allow you to pull out the dish and check it without having to remove it from the oven entirely.

 The **inner door glass** can be removed with a few quick movements for cleaning.

 **Gas ovens** offer instantaneous heat control, reduced cooking times and the ability to bake at much lower temperatures than electric ovens.

 **Microwave energy** shortens cooking times drastically and produced notable energy savings.

 **Air cooling system** to ensure a safe surface temperatures.

**P ECO P** **Pyrolytic cleaning cycles** can be selected as necessary to automatically clean the oven interior.

 The **SmartSense cooking** system allows the user to customise their dish with a few simple steps.

 The **enamel interior** of all Smeg ovens have a special antacid lining which helps keep the interior clean by reducing the amount of cooking grease adhering to it.

 Two opposing **side lights** increase visibility inside the oven.

**4** **Quadruple glazed** doors keep surface temperatures as low as possible and are featured on all Pyrolytic ovens.

**3** **Triple glazed doors** are featured on several Smeg appliances.

**P 13 A** A simple **13 amp supply** is required to connect any Smeg single pyrolytic oven.

 **Combination microwave** ovens can be used either as a microwave, or as a traditional oven, or alternatively the two methods can be combined.

 **Combination steam** ovens can be used either as a steam oven, or as a traditional oven, or alternatively the two methods can be combined.

 **All glass inner door**, a single flat surface which is simple to keep clean.

 **Surfaceplus ceramic base** for a microwave oven - no turntable required, and the whole surface can be used for cooking.

 **Vapor Clean**, a simple cleaning function using steam to loosen deposits in the oven cavity.

### COFFEE MACHINE

 Coffee beans can be used in this appliance.

 Ready ground coffee can be used in this appliance.

 **3 adjustable coffee lengths** and **5 levels of coffee strength** can be chosen in this appliance.

# SYMBOLS GUIDE

## HOB & COOKERS



Heavy duty cast iron pan stands for maximum stability and strength.



Directional burners have an almost vertical flame which transfers real power to the pot.



Ultra low option is ideal for melting chocolate or butter or simply to keep food warm.



All ceramic hobs have a timer which automatically ends cooking after a preset time.



Multizone allows several pans to be used at once, large or small, offering freedom of placement and greater flexibility.



Time elapsed shows how long the cooking zone has been in use.



Evershine is an invisible coating that makes the effected area highly resistant to heat.



Powerful ultra rapid burners offer up to 5kw of power.



A reinforced base, developed exclusively by Smeg, consists of a steel layer fixed to the underside of the glass surface of all gas on glass hobs.



Power booster option allows the zone to work at full power when very intense cooking is necessary.



When the Quick Start function is selected, the chosen temperature is reached faster. The heating element works at maximum power until the right temperature is reached.



The giant zone offers extra space and flexibility.



Dual zone adds extra versatility and optimum choice for the use of different sized pans.

## FIRES



A flueless gas fire is 100% efficient, converting 100% of the gas used to heat, unlike an open or coal fire, which can convert as little as 10%.



Flueless natural gas fires are very eco friendly, with running costs typically a third of those for a conventional gas fire, saving energy and reducing the carbon footprint.

## COOKER HOODS



Electronic display to give a visual reminder of the options selected.



Intensive/turbo setting, when extra fast extraction is required.



When selected this function refreshes the air for c. 10 minutes every hour over a 24 hour period, at minimum speed and an imperceptible noise level.



Extracting through charcoal filters or directly to the exterior lessens strong cooking odours considerably.



A special setting, to run after the end of cooking for a pre-set time and then switch off automatically.



Perimeter extraction panels, very efficient and aid noise reduction.



Warning light(s) to advise when filters need changing.



Model has filters to help remove grease from the steam emanating from the pans during cooking.



All cooker hoods feature lights to illuminate the cooking area or add to the ambience of the kitchen.

## REFRIGERATION



The cool n fresh compartment keeps food fresher for longer.



The fast freezing function brings the temperature of the compartment down when activated a few hours prior to usage.



LED interior lighting is a more energy efficient and long lasting way of illuminating the interior of the appliance.



Excellent insulation and special devices keep noise to a minimum.



The temperature in the Lifeplus compartments is kept at 0°C which preserves fresh meat and fish longer.



This unique Active Fresh Blue lighting system works with nature to increase the storage time of fruit and vegetables.



The No Frost and Frost free systems prevent ice from forming so that no defrosting is required.



The automatic defrost system works by automatically defrosting at regular intervals eradicating the need to defrost altogether.



The power saving mode allows you to disable the refrigerator and keep the freezer working.



Air plus keeps food fresher for longer.



The Multizone compartment can be used as either a refrigerator or a freezer depending on needs.

# SYMBOLS GUIDE

## DISHWASHERS



**Orbital wash system** distributes water evenly throughout the 60cm dishwasher cavity, directing water with precision to ensure an excellent wash.



The **Swing Wash system** ensures optimum water distribution throughout 45cm dishwasher tanks to deliver excellent wash results.



The **FlexiDuo 3rd cutlery basket** allows you to arrange cutlery or small cups, ladles, or bulky utensils however you like: it consists of two separate and moveable modules.



The **auto programme** regulates the length of a cycle depending on the need for a pre-wash and the number of rinses required.



The **delay timer** can postpone the start of the programme by up to 24 hours.



The **rapid 27 mins quick programme** takes just 27 minutes to wash a load.



The **hyclean** option performs a final 10 minute rinse at a high temperature of 70°C eliminating virtually all bacteria.



**Total acquastop** is an electronic device which monitors water levels in the machine to detect leaks in the hose and switch off the water supply immediately if necessary.



The normal programme is suitable for normal degrees of dirt for everyday use.



**Eco**, this economic wash programme uses a low amount of water and energy in order to provide the most environmentally friendly cleaning option.



**Blue interior lights** to illuminate the inside of the dishwasher.



**Eco**, this economic wash programme uses a low amount of water and energy in order to provide the most environmentally friendly cleaning option.



**Blue interior lights** to illuminate the inside of the dishwasher.



The **FlexiTime** option allows the user to reduce the time of the cycle selected, providing extra flexibility and control.



**Super fast 15 min**: a programme designed to wash small amounts of laundry fast, ideal for washing lightly soiled garments.



A **cleaning programme** has been created to maintain the performance of washer/dryers. The display shows automatically when cleaning is required.



Drum has maximum capacity of **7kg of dry laundry**.



**Delay timer**, can be set to run the programme at a convenient time or to take advantage of off-peak energy periods.



**Shirts**, a cycle to wash shirts in a short time with the utmost care, using a delicate spin for easy ironing.



**Hand wash**, this specific programme for delicate fabrics uses slower rotations of the drum to ensure the utmost care for clothing.



**Easy Iron**, this is an option which can be selected to ensure the finished laundry is left with less creases to make ironing easier.



**Internal lights** help to illuminate the inside of the drum.



**LED display**, to show programmes, functions and options selected and the time to the end of the cycle.



The wool cycles of the Smeg tumble dryer dry all of your woollen items with the gentlest treatment possible.



The **1/2 load flexizone** allows you to wash a reduced load saving energy, water and time and there are no restrictions on where the items are placed.



**Aquatest** measures the clarity of the water during an auto programme, and automatically ensures the minimum consumption of water and energy.



At the end of the drying cycle the **Enersave** device slowly opens the door which ensures perfect drying.



The **quick time** option can reduce the length of the wash cycle up to 55%.



**Flexitabs** adjusts the wash cycle to give the best possible results regardless of the type of detergent used.



The **crystal cycle** is designed especially for glass ware and for delicate dishes with light dirt.



The **Strong & Fast** programme takes less than 1 hour to eliminate the most stubborn dirt and dried on residues.



The soak programme provides a rinse to prevent dirt from drying.



The super programme is suitable for removing stubborn dirt.



The symbols show the number of plate settings of the dishwasher.



**Activelight** is an led light which projects a red spot onto the floor beneath the dishwasher when the appliance is in use.



The symbols show the number of plate settings of the dishwasher.



**Activelight** is an led light which projects a red spot onto the floor beneath the dishwasher when the appliance is in use.

## LAUNDRY



**Night**: an ideal programme for those who want to take advantage of off-peak energy periods, this cycle is particularly quiet due to slower rotations of the drum.



**Jeans**: a washing cycle which is kind to the colour and fabric of denim whilst minimising wrinkles.



The **Extra rinse** option: can be added to the selected programme when more thorough cleansing of special fabrics is needed.



**LED display**, to show programmes, functions and options selected and the time to the end of the cycle.



**Total acquastop**, the product is built with 3 levels of anti-flood devices to ensure protection against water leakage.



**Gym**, a cycle designed for washing lightly soiled garments, ie sports wear, this is a fast wash which is also kind to fabrics.



**Mixed fabrics**, this cycle is designed for lightly soiled laundry in a mix of cottons and synthetics, or can be used just to refresh stored items.



Clothing such as underwear, hosiery and luxury fabrics should be dried on the delicate cycle to help extend the life of the clothing.



The "Wardrobe Dry" cycle allows clothing to be dried so that it can be put away straight from the machine.

## OVEN FUNCTIONS

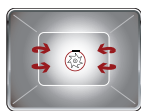

### Circulaire:

The combination of the fan and circular element around it gives a hot air cooking method. This provides many benefits including no preheat if cook time is more than 20 minutes, no flavour transfer when cooking different foods at the same time, less energy, and shorter cook times. Good for all types of food.

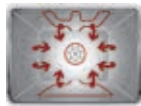

### Circulaire with upper and lower elements (Turbo):

The use of the fan with both elements allows food to be cooked quickly and effectively, ideal for large joints that require thorough cooking. It offers a similar result to rotisserie, moving the heat around the food, instead of moving the food itself, enabling any size or shape to be cooked.



### Circulaire with lower element:

The addition of the lower element adds extra heat at the base for food which requires extra cooking.



### Circulaire with upper element or grill:

Similar to fan with upper element with the added cooking speed of circulaire, ideal for dishes with a crispy topping. When used with the grill the food will brown more quickly.

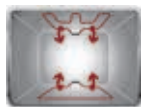

### Upper and lower element only:

A traditional cooking method best suited for single items located in the centre of the oven. The top of the oven will always be hottest. Ideal for roast, fruit cakes, bread etc.



### Lower heating element only:

Ideal for foods that require extra base temperature without browning, e.g. pastry dishes, pizza. Also suitable for slow cooking of stews and casseroles.



### Top element only:

Useful for browning the tops of dishes such as lasagne and potato or cheese topped recipes.

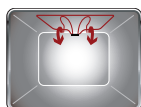

### Grill element/Half grill:

For rapid cooking and browning of foods. Best results can be obtained by using the top shelf for small items, the lower shelves for larger ones, such as chops or sausages. For half grill heat is generated only at the centre of the element, so is ideal for smaller quantities.

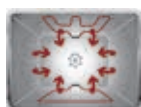

### Fan with upper and lower elements:

The elements combined with the fan aim to provide more uniform heat, a similar method to conventional cooking, so pre-heat is required. Most suitable for items requiring slow cooking methods.



### Fan with upper element:

The same functionality as top element only but will distribute the heat around the cavity allowing for plate warming etc at the same time.

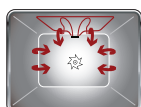

### Fan with grill element:

The fan reduces the fierce heat from the grill, providing an excellent method of grilling various foods, chops, steaks, sausages etc. giving even browning and heat distribution, without drying

out the food. The top two levels recommended for use, and the lower part of the oven can be used to keep items warm at the same time, an excellent facility when cooking a grilled breakfast. Half grill (centre portion only) is ideal for small quantities of food.

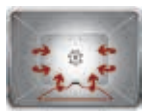

### Fan with lower element:

This combination completes cooking more quickly of foods that are ready on the surface, but require more cooking inside, without further browning.

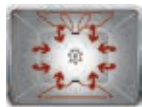

### Pizza function:

The simultaneous operation of these three elements ensures an optimum cooking facility when used with the Smeg pizza stone.



### Defrost:

Both symbols refer to the same function. The circulation of air enables quicker thawing of frozen food, without the use of any heat. Ideal for use prior to cooking of ready-made dishes, or cream filled products etc.



### Snowflake:

With the switch on this symbol, no heating is possible even if the thermostat is turned.



### Fan:

As above but with thermostat set a '0'.



### Bread proving:

Air at 40°C provides the perfect environment for proving yeast type dough mixes. Simply select the function and place dough in the cavity for allotted time.

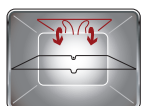

### Rotisserie:

The rotisserie (where installed) works in combination with the grill element whilst constantly turning the food.



These symbols allow use of the rotisserie with full or half grill.



This symbol adds top heat to cook food more quickly.



This symbol adds the fan to distribute the heat quickly and evenly.



### ECO

The combination of the grill, fan and lower element is particularly suitable for cooking small quantities of food.



### Eco Circulaire:

Some cooker models have Eco Circulaire in place of Circulaire but the 2 functions work in the same way. This is the most energy efficient standard oven function for the cooker.

## GAS OVEN FUNCTIONS



Gas burner only:  
traditional convection cooking.



Gas burner only:  
can also be used in conjunction with the rotisserie.



Circogas:  
The fan is added to the gas burner to distribute the heat quickly and evenly throughout the oven cavity, avoiding flavour transfer when cooking a number of different dishes at the same time.



circogas can also be used in conjunction with the rotisserie.



This catalogue is printed entirely on FSC® (Forest Stewardship Council®) certified paper that has been produced with cellulose sourced from forests that are managed responsibly, in accordance with rigorous environmental, social, economic and cultural standards.  
<http://www.fsc.org/>

Whereas every effort has been made to ensure that the information and images contained in our literature are correct at time of going to print, this brochure should not be regarded as an infallible guide to current specification, nor does it constitute an offer for sale of any particular product.



[www.smeguk.com](http://www.smeguk.com)

**Smeg (UK) Limited**

3A Park Square, Milton Park, Abingdon  
Oxon OX14 4RN

**Information line**

Tel. 0844 5579907 Fax. 0844 5579337

**Trade Enquiries**

Tel 0844 5570070 Fax 0844 5574355

**Service & Spare Parts**

Tel. 0844 5579907 Fax. 0844 5579336