

## Cucina Selection

This collection of built-in appliances has been specially selected for suitability in the contract market.

These products combine elegance and advanced technology to provide style and reliability, satisfying the needs of the most discerning customer.

With cooking, refrigeration, dishwashing, laundry, sinks and taps the Cucina Selection offers the contract buyer a complete kitchen portfolio.



The Cucina Selection is made up of a range of selected products designed specifically with the contract market in mind. The new range offers both existing products in addition to a number of new models that further extend the range, providing an extensive and comprehensive choice for any new kitchen. Alternative and additional products to those in this collection are featured in the Smeg main range, which can be viewed at [www.smeguk.com](http://www.smeguk.com)

### Ovens



In order to continually improve the Cucina range the oven control knobs have been re-designed into a new sleek and elegant style, and the single oven cavities have been increased to an impressive 72 litres. The SFP485 ovens have a Pyrolytic cleaning function which works by heating the inside of the oven to 500°C, at which temperature any grease stuck to the walls is simply burnt off. SF485 & SF478 models include a cleaning function called Vapor clean, designed to make oven cleaning a simple task. The SF478 entry model also features an electronic clock as well as a variety of interesting features, making this oven the perfect choice for any home.

The double ovens have also benefited from an increase in cavity sizes, new style controls and a new aesthetic that brings them in line with the rest of the Cucina single ovens. These are available for both in column and under worktop installation.

New to the 2013 range are a reduced height compact combination microwave oven, providing further options for equipping your kitchen, and a microwave oven with grill, which has a side opening door for easy access and a 320mm depth which allows the appliance to be installed into a wall unit.

In addition to the above there is a standard built-in microwave oven with grill and a 90cm dual fuel stainless steel range cooker with two ovens, which now boasts a generous 72 litre main cavity.

As a finishing touch glass splashbacks and upstands can be used to co-ordinate or contrast with the ovens and hobs as an alternative to tiling - see page 21 for more details.

### Hobs



New style Cucina control knobs have been introduced throughout the range where possible and most gas hobs now feature heavy duty cast

iron pan stands instead of enamel, providing maximum safety with more stability so that pans can be easily moved from burner to burner.

Enabling professional cooking, the SI3644B 60cm induction hob is a quick reacting appliance that also reduces energy consumption making this a superb choice for any kitchen. Providing further versatility of range options the S232XC 30cm electric hob is designed with two plates making it ideal for the more compact kitchen, whilst the 90cm SRV596GH5 gas hob is the widest hob in the Cucina selection allowing a much greater usable space for the consumer. The SRV596GH5 is the only hob that comes fitted with "Contemporary" controls but the new style Cucina control knobs can be purchased as an optional extra.

### Hoods



Intended to present the finest blend of elegance and functionality the Cucina hoods are composed of the highest grade stainless steel adding to their modern and contemporary design. The range includes the impressive KI90C-1 90cm Island hood which boasts an extraction rate of 660 m<sup>3</sup>/h. In addition to chimney hoods the Cucina selection also offers a range of integrated hoods including the telescopic KSET61, and canopy hood KI52-1, ideal for compact kitchens. All Cucina hoods can be operated in either a ducted or recirculation mode.



## Refrigeration

All Cucina refrigeration models achieve an A+ energy rating for energy efficiency. This selection offers a number of in-column and under worktop refrigeration products, presenting the consumer with plenty of choice. These integrated appliances discreetly merge into a kitchen, creating a simple and chic appearance. The range also features two freestanding American side by side refrigerator-freezers with a dispenser for cold water and ice, either crushed or cubed. Both models are completely frost free and the SS55PTLH3 features a home bar, where bottles and cans can be stored.



## Dishwashers



The updated A+ rated 45cm model DIC4-1 uses the new SwingWash spray system which further improves the wash coverage in the rectangular shaped tank by the addition of an extra spray arm which directs water towards the corners, swinging alternately between the rear and the front of the machine during the cycle.

The DIC6-1 60cm fully integrated model and the DDC6-1 60cm drawer line model are both now rated A+ for energy efficiency, and for smaller kitchens where space may be at a premium we can offer the 60cm 7 place horizontal fully integrated model DI607.

## Laundry



All laundry products in the Cucina selection now feature a large 7kg load capacity.

A series of special programmes and functions together with traditional programmes provide the best washing care. Programmes can be customised by selecting various options such as temperature and spin speed, which make doing the laundry easier and more efficient.

## Sinks & Taps



Cucina sinks are manufactured in high grade stainless steel with an impressive bowl depth of 180mm. They are reversible, and are available in single bowl single drainer, or one and a half bowl single drainer versions. Cucina taps are produced with a sleek chrome finish in either a single lever or dual flow mixer tap design to perfectly harmonize with Smeg sinks. A variety of sink accessories in the main range can also be purchased to complement the Cucina sinks.

# DOUBLE OVENS

## DOSF44X

60CM "CUCINA" MULTIFUNCTION DOUBLE OVEN, FINGER FRIENDLY ST/STEEL

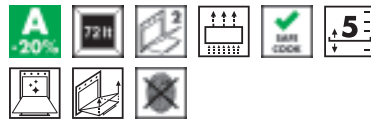

### LOWER MAIN OVEN

4 functions inc circulaire element with fan



Electronic clock/programmer

Air cooling system

**Closed door grilling**

Removable inner door glasses

5 cooking levels

Metal side supports

Easy clean enamel interior

**Oven capacity: gross - 79 litres, net - 72 litres**

Forced air convection: 0.79kW/h

### STANDARD ACCESSORIES:

2 x Extra deep trays (40mm deep)

2 x Chrome shelves

2 x Grill mesh

### OPTIONAL EXTRAS

Pair of fully extractable telescopic guides

GT1T-1

Pair of partially extractable telescopic guides

GT1P-1

Pizza Shovel

PALPZ

Pizza Stone

PRTX

Stay clean liners (for main oven)

PC68

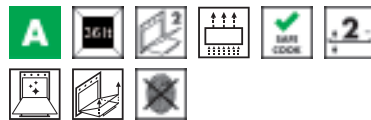

### UPPER AUXILIARY OVEN

4 functions inc upper & lower element



Variable grill

Air cooling system

**Closed door grilling**

Removable inner door glasses

2 cooking levels

Easy clean enamel interior

**Oven capacity: gross - 41 litres, net - 36 litres**

Conventional: 0.59kW/h

Nominal power: 5.60 kW

Power supply required: dedicated circuit fused at 30 Amp, or a 32 Amp circuit breaker



## DOUBLE OVENS



DOSF44X

# DOUBLE OVENS

## DUSF44X

60CM "CUCINA" DOUBLE UNDER COUNTER  
MULTIFUNCTION OVEN, FINGER FRIENDLY ST/STEEL

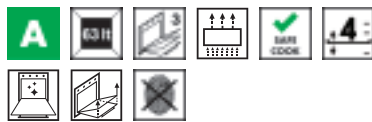

### LOWER MAIN OVEN

4 functions inc circulaire element with fan



Electronic clock/programmer

Air cooling system

**Closed door grilling**

4 cooking levels

Metal side supports

Easy clean enamel interior

Removable inner door glasses

**Oven capacity: gross - 70 litres, net - 63 litres**

Forced air convection: 0.79 kW/h

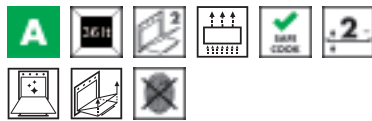

### UPPER AUXILIARY OVEN

4 functions inc upper & lower element



Variable grill

Air cooling system

**Closed door grilling**

2 cooking levels

Easy clean enamel interior

Removable inner door glasses

**Oven capacity: gross - 41 litres, net - 36 litres**

Conventional: 0.59kW/h

Nominal power: 5.60 kW

Power supply required: dedicated circuit

fused at 30 Amp, or a 32 Amp circuit

breaker

### STANDARD ACCESSORIES:

2 x Extra deep trays (40mm deep)

2 x Chrome shelves

2 x Grill mesh

### OPTIONAL EXTRAS

Pair of fully extractable  
telescopic guides

GTIT-1

Pair of partially extractable  
telescopic guides

GT1P-1

Pizza Shovel

PALPZ

Pizza Stone

PRTX

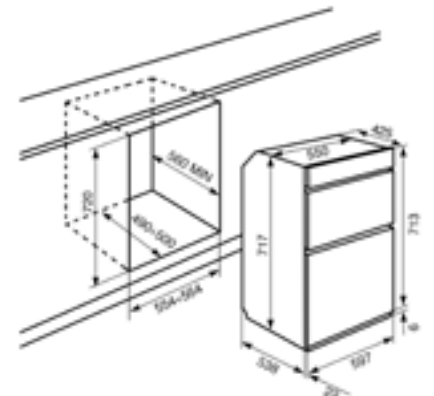

NB: Due to the restricted space remaining beneath the work surface above this oven unit, care must be taken when selecting a hob to ensure it will fit

## DOUBLE OVENS



DUSF44X

# OVENS

## SFP485X

60CM PYROLITIC MULTIFUNCTION OVEN,  
FINGER FRIENDLY ST/STEEL



8 functions Inc Circulaire with upper & lower element



Electronic programmer  
Air cooling system  
**Closed door grilling**  
Quadruple glazed removable door  
Easy clean enamel interior  
5 cooking levels  
Metal side supports  
Removable inner door glass  
**Rapid pre-heating**  
**Energy saving option - Ecologic**  
**Pyrolytic cleaning**  
Electronic display with child lock

Maxi plus oven GROSS capacity: 79 litres  
Maxi plus oven NET capacity: 72 litres  
Nominal power: 3.0kW  
**13 Amp power supply required**

STANDARD ACCESSORIES:  
Extra deep tray (40mm deep)  
Grill mesh  
Chrome shelf

OPTIONAL EXTRAS:  
Pair of fully extractable telescopic guides GT1T-1  
Pair of partially extractable telescopic guides GT1P-1  
Pizza stone PRTX  
Folding pizza shovel PALPZ



SFP485N  
Black

## SF485X

60CM MULTIFUNCTION OVEN,  
FINGER FRIENDLY ST/STEEL

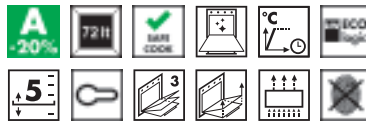

8 functions Inc Circulaire with upper & lower element



Electronic clock/timer  
Air cooling system  
**Closed door grilling**  
Easy clean enamel interior  
5 cooking levels  
Metal side supports  
Removable inner door glass  
**Rapid pre-heating**  
**Energy saving option - ecologic**  
**Vapor clean programme**  
Electronic display with child lock

Maxi plus oven GROSS capacity: 79 litres  
Maxi plus oven NET capacity: 72 litres  
Nominal power: 3.0 kW  
**13 Amp power supply required**

STANDARD ACCESSORIES:  
Extra deep tray (40mm deep)  
Grill mesh  
Chrome shelf  
Roof liner

OPTIONAL EXTRAS:  
Pair of fully extractable telescopic guides GT1T-1  
Pair of partially extractable telescopic guides GT1P-1  
Stay clean liners PC68  
Pizza stone with handles PRTX  
Folding pizza shovel PALPZ



SF485N  
Black

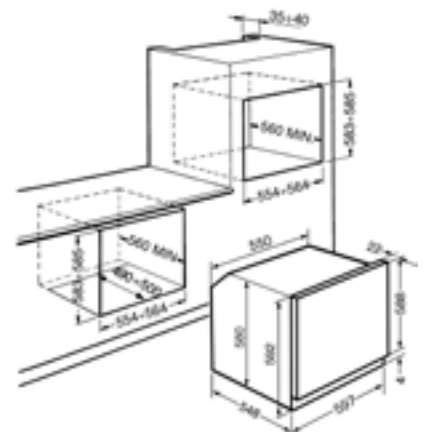

OVENS



SF485N

# OVENS

## SF478X

60CM MULTIFUNCTION OVEN,  
FINGER FRIENDLY ST/STEEL



9 functions Inc Circulaire with upper & lower element



- Electronic clock/timer
- Electronic programmer
- Double glazed door
- Removable inner door glass
- Air cooling system
- Closed door grilling**
- Easy clean enamel interior
- 5 cooking levels
- Metal side supports
- Vapor clean programme**

Maxi plus oven GROSS capacity: 79 litres  
Maxi plus oven NET capacity: 72 litres  
Nominal power: 3.0kW  
**13 Amp power supply required**

**STANDARD ACCESSORIES:**

- Extra deep tray (40mm deep)
- Grill mesh
- Chrome shelf
- Roof liner

**OPTIONAL EXTRAS:**

- Telescopic guides (total extraction) GT1T-1
- Telescopic guides (partial extraction) GT1P-1
- Pizza stone PRTX
- Pizza shovel PALPZ
- Stay clean liners PC68



SF478N  
Black

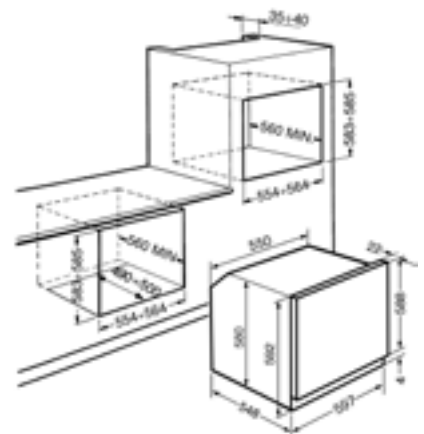



SF478X

# MICROWAVE

## SC445MCX1

60CM COMPACT COMBINATION  
MICROWAVE OVEN, FINGER-FRIENDLY  
ST/STEEL



45cm reduced height compact oven

6 functions Inc Circulaire element with fan

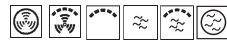

Electronic timer with end of cooking alarm  
Minute minder  
Air cooling system  
Closed door grilling  
Full fan cooking (can also be combined with  
microwave)  
Metal side supports  
3 cooking levels  
Stainless steel interior  
1 x 20W light

Oven GROSS capacity: 37 litres

Oven NET capacity: 34 litres

### STANDARD ACCESSORIES:

Glass tray  
Chrome shelf

Microwave output power: 1.00 kW

Grill power: 1.50 kW

Nominal power: 3.40 kW

30 Amp power supply required

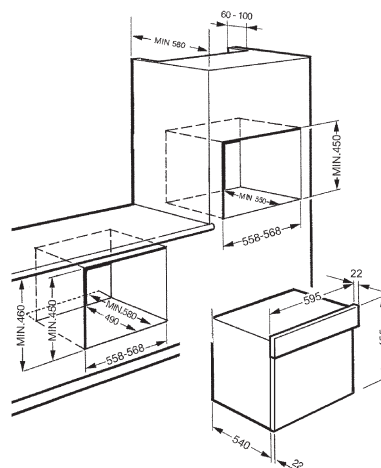

MICROWAVE



SC445MCX1

# MICROWAVE

## MP322X

60CM MICROWAVE OVEN WITH ELECTRIC GRILL, FINGER FRIENDLY ST/STEEL  
320MM DEPTH ALLOWS INSTALLATION IN WALL UNIT



6 functions Inc pizza

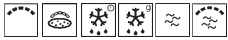

Side opening door

Controls positioned at the bottom

Electronic timer

Tilting grill

Quartz grill: 1.2 kW

Microwave output power: 850 W

22 litre capacity

Surfaceplus ceramic base

Air cooling system

Automatic calculation of defrosting by time or weight

Quick start option

Child safety lock

STANDARD ACCESSORIES:

Chrome grill support

Set of Cucina Selection control knobs

OPTIONAL EXTRAS:

KITMP38 – thinner bar to reduce height to 38cm

KITPLATE – crisper

NB: This model has interchangeable aesthetics.

It comes fitted with "Classic" controls, and Cucina Selection controls are provided as

standard accessories.

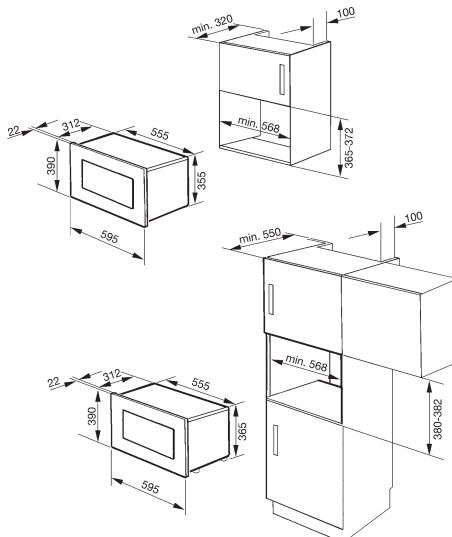

## M120X-1

60CM MICROWAVE OVEN WITH ELECTRIC GRILL, FINGER FRIENDLY ST/STEEL

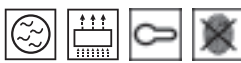

4 functions Inc Grill



Electronic timer

Delay start

End of cooking acoustic alarm

Quartz grill: 1.0 kW

Microwave output power: 800 W

20 litre capacity

St/steel interior

Cooling system

Automatic calculation of defrosting by time or weight

Quick start option

Child safety lock

Memory function

STANDARD ACCESSORIES:

Chrome grill support

Kit for build in installation

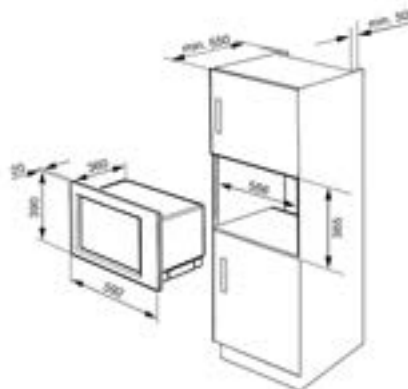



MP322X

**SRV596GH5**

90CM GAS HOB, ST/STEEL



5 burners  
 Rear left: 3.00 kW  
 Front left: 1.00 kW  
 Centre: Ultra-rapid 3-way burner: 5.00 kW (3.90 + 1.10kW)  
 Rear right: 1.60 kW  
 Front right: 1.60 kW

St/Steel base  
 "Contemporary" controls  
**Heavy duty cast iron pan stands**  
 Black burner caps

Automatic electronic ignition  
 Safety valves  
 Adaptable for LPG

Nominal power: 12.40 kW  
 Total connected load: <1.00 kW

OPTIONAL EXTRA:  
 Set of 6 new style Silver Cucina controls  
**6MPF2465X**

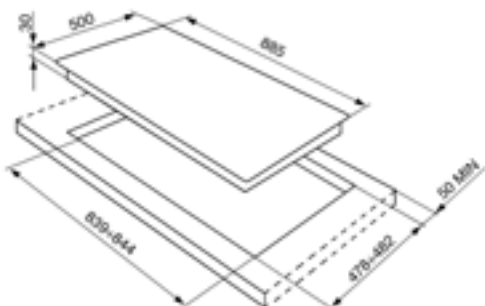

**SR275XGH**

70CM GAS HOB, ST/STEEL



5 burners  
 Rear left: 2.55 kW  
 Front left: 1.05 kW  
 Centre: Ultra Rapid burner 3.90 kW  
 Rear right: 1.65 kW  
 Front right: 1.65 kW

St/Steel base  
**New style Silver Cucina controls**  
**Heavy duty cast iron pan stands**  
 Black burner caps

Automatic electronic ignition  
 Safety valves  
 Adaptable for LPG

Nominal power: 10.80 kW  
 Total connected load: <1.00 kW

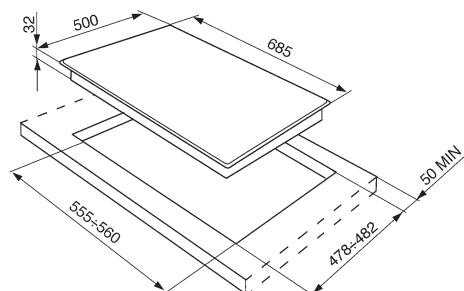

**SR264XGH**

60CM GAS HOB, ST/STEEL



4 burners in "diamond" configuration  
 Left: Ultra Rapid burner 3.90kW  
 Centre front: 1.05kW  
 Centre rear: 1.65kW  
 Right: 2.55kW

St/steel base  
 New style Silver Cucina controls  
 Heavy duty cast iron pan stands  
 Black burner caps

Automatic electronic ignition  
 Safety valves  
 Adaptable for LPG

Nominal power: 9.15 kW  
 Total connected load: <1.00 kW

**S64S**

60CM GAS HOB, ST/STEEL



4 burners  
 Rear left: 1.80 kW  
 Front left: 3.10 kW  
 Rear right: 1.80 kW  
 Front right: 1.05 kW

St/steel base  
 New style Silver Cucina controls  
 Enamelled pan stands  
 Black burner caps

Automatic electronic ignition  
 Safety valves  
 Adaptable for LPG

Nominal power: 7.75 kW  
 Total connected load: <1.00 kW



**S64SN**  
 Black with New style  
 Black Cucina controls

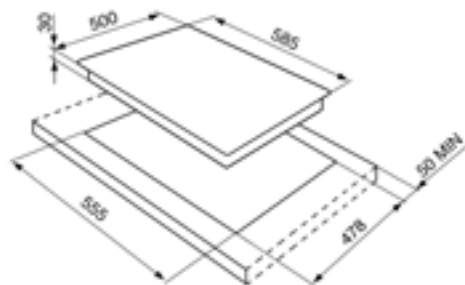
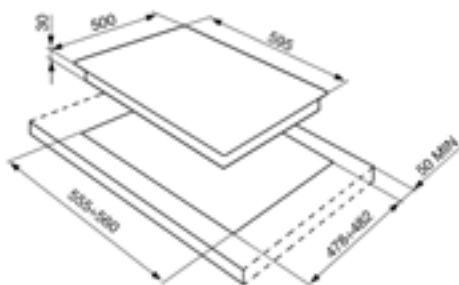

**SI3644B**

60CM TOUCH CONTROL INDUCTION HOB WITH ANGLED EDGE GLASS



4 full power induction zones  
 Front left: ø 210/100mm, 1.85kW – booster 2.3kW  
 Rear left: ø 180/100mm, 1.65kW – booster 2.3kW  
 Rear right: ø 210/100mm, 1.80kW – booster 2.3kW  
 Front right: ø 160/100mm, 1.25kW – booster 2.0kW

“Suprema” black ceramic glass  
 4 boosters  
 9 power levels  
 Electronic timer which can be used with all zones  
 Residual heat indicators  
 End of cooking acoustic alarm  
 Automatic safety cut-out  
 Child safety lock

Nominal power 7.2 kW  
 Power supply required: dedicated circuit fused at 30 Amp, or a 32 Amp circuit breaker

NB: Only pans with a ferrous (magnetic) base are suitable for induction hobs

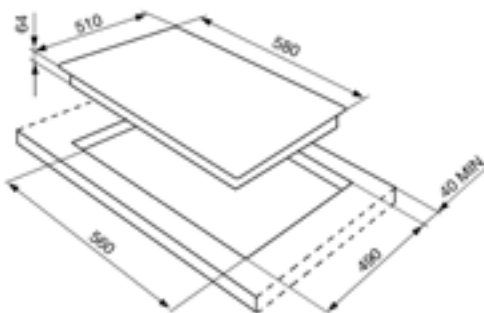

**SE2640TD2**

60CM TOUCH CONTROL CERAMIC HOB WITH STRAIGHT EDGE GLASS

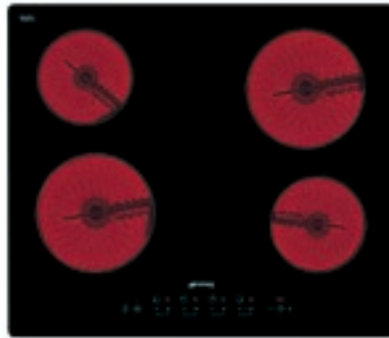

4 “High-light” radiant cooking zones  
 Rear left: ø 140mm, 1.20 kW  
 Front left: ø 180mm, 1.80 kW  
 Rear right: ø 180mm, 1.80 kW  
 Front right: ø 140mm, 1.20 kW

“Suprema” black ceramic glass  
 9 power levels  
 Independent timer  
 Residual heat indicators  
**Energy saving option**  
 End of cooking acoustic alarm  
 Automatic safety cut-out  
 Child safety lock

Nominal power: 6.20 kW  
 Power supply required: dedicated circuit fused at 30 Amp, or a 32 Amp circuit breaker

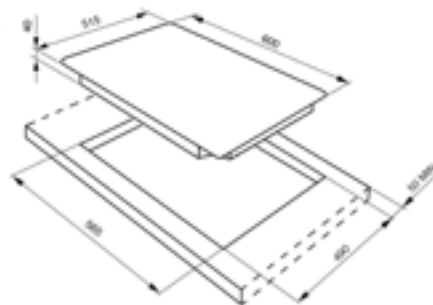

**S264C**

60CM SILVER CONTROL CERAMIC HOB WITH STRAIGHT EDGE GLASS

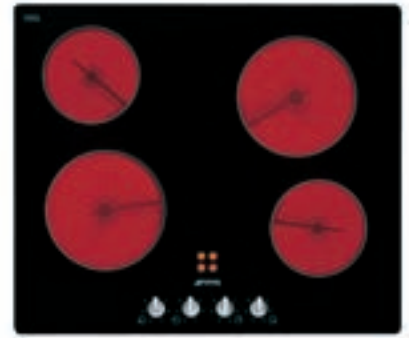

4 “High-light” radiant cooking zones  
 Rear left: ø 140mm, 1.20 kW  
 Front left: ø 180mm, 1.80 kW  
 Rear right: ø 180mm, 1.80 kW  
 Front right: ø 140mm, 1.20 kW

Front new style Silver controls to match Cucina ovens  
 “Suprema” black ceramic glass  
 6 power levels  
 Residual heat indicators  
 Automatic safety cut-out

Nominal power: 6.00kW  
 Power supply required: dedicated circuit fused at 30 Amp, or a 32 Amp circuit breaker

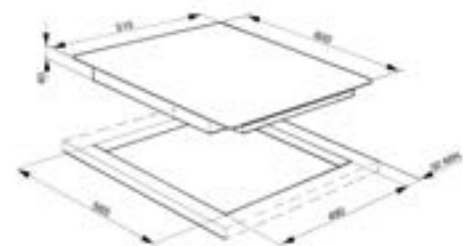

**S232XC**

30CM ELECTRIC HOB,  
ST/STEEL



2 plate electric hob  
Rear fast plate:  $\varnothing$  180mm,  
2.00 kW  
Front fast plate:  $\varnothing$  145mm,  
1.50 kW

New style Silver Cucina  
controls

Nominal power: 3.50 kW  
Power supply required:  
dedicated circuit fused at  
30 Amp, or a 32 Amp  
circuit breaker

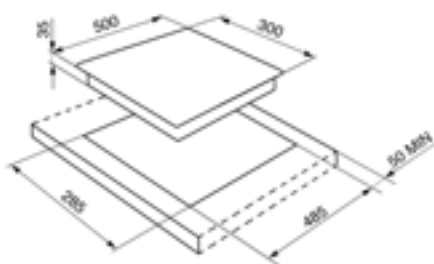

**SE435S**

60CM ELECTRIC HOB, ST/STEEL



4 plate electric hob  
2 fast plates  
Rear left:  $\varnothing$  145mm, 1.50 kW  
Front left:  $\varnothing$  180mm, 1.50 kW  
Rear right:  $\varnothing$  180mm, 2.00 kW  
Front right:  $\varnothing$  145mm, 1.00 kW

New style Silver Cucina controls

Nominal power 6.00kW  
Power supply required: dedicated circuit fused at  
30 Amp, or a 32 Amp circuit breaker

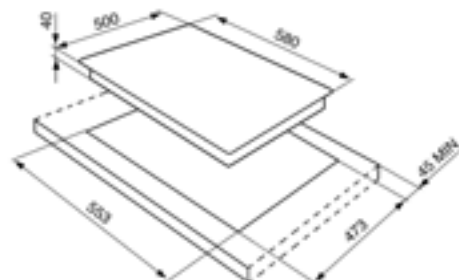

**CC92MX9**

90CM COOKER WITH DOUBLE OVEN AND GAS HOB, ST/STEEL



Photo shows legs & plinth fitted



**MAIN OVEN:**  
8 functions Inc Circulaire element with fan



Oven capacity: gross - 79 litres, net - 72 litres  
Digital electronic clock/programmer

Air cooling system  
**Closed door grilling**  
Easy clean enamel interior  
5 cooking levels  
Metal side supports

**Vapor clean programme**  
Conventional: 0.80kW/h  
Forced air convection: 0.69kW/h



**AUXILIARY OVEN:**  
4 functions Inc upper & lower element

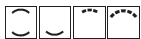

Oven capacity: 39 litres, net - 35 litres  
Variable grill

**Closed door grilling**  
Air cooling system  
Easy clean enamel interior  
Conventional: 0.59kW/h

**HOB:**  
5 burner gas hob  
Rear left: 1.80kW  
Front left: Rapid 3.0kW  
Centre: Ultra rapid 3.5kW  
Rear right: 1.80kW  
Front right: 1.00 kW  
Enamelled pan stands  
Automatic electronic ignition  
Safety valves  
Adaptable for LPG

Black feet and black plinth provided  
Nominal power: 4.30 kW  
Power supply required: dedicated circuit fused at 30 Amp, or a 32 Amp circuit breaker

**STANDARD ACCESSORIES:**  
**MAIN OVEN:**  
Extra deep tray (40mm deep)  
Grill mesh  
Chrome shelf

**AUXILIARY OVEN:**  
Roasting/grill pan  
Grill mesh  
Chrome shelf

**OPTIONAL EXTRAS**  
Splashback  
Pizza stone  
Pizza shovel  
Wok support  
Teppanyaki grill plate  
Pair of fully extractable telescopic guides  
Pair of partially extractable telescopic guides

**KIT90X**  
**PRTX**  
**PALPZ**  
**WOKGHU**  
**TBX6090**  
**GT1T-1**  
**GT1P-1**



NB: Height with plinth installed is fixed at 900mm









## GLASS SPLASHBACKS & UPSTANDS

A number of eye-catching glass splashbacks are included in the Smeg range, that are available in a wide choice of inspiring colours, finishes and sizes to enhance the diverse range of appliances.

The 8 colours available particularly complement the iconic Smeg 50's Retro appliances as well as Black, Cream and Stainless Steel products. There are also matching 140mm high upstands available which can be fitted on the wall behind the worktop. Upstands can be cut to size by the installer to ensure a perfect fit.

Splashbacks are a practical addition to any kitchen as they are easy to clean, with no grout lines to collect dirt or grease. They are also a very cost effective alternative to tiles that are simple and easy to install and result in a smooth and seamless finish.

The table below shows the various colours and dimensions available.

SPLASHBACKS				UPSTANDS
DIMENSIONS	60CM W X 75CM H	75CM W X 75CM H	90CM W X 75CM H	2 X 100CM W X 14CM H
GLASS COLOUR	MODEL NOS	MODEL NOS	MODEL NOS	MODEL NOS
BLACK 	SPG6075NE	SPG7575NE	SPG9075NE	UPGNE
CREAM 	SPG6075P		SPG9075P	UPGP
RED 	SPG6075R		SPG9075R	UPGR
PASTEL BLUE 	SPG6075AZ		SPG9075AZ	UPGAZ
LIME 	SPG6075VE		SPG9075VE	UPGVE
SILVER 	SPG6075S	SPG7575S	SPG9075S	UPGS
MATT WHITE 	SMG6075B	SMG7575B	SMG9075B	UMGB
MATT BLACK 	SMG6075NE	SMG7575NE	SMG9075NE	UMGNE

# HOODS

## KI90C-1

90CM ISLAND HOOD, ST/STEEL



1 high performance motor 250W  
3 speeds  
4 x 20W halogen lights  
3 aluminium grease filters  
Internal re-circulation possible  
Vent outlet ø 150mm  
Nominal power: 330W

Speed	Extraction rate IEC 61591 (m³/h)	Noise Level IEC 60704-2-13 dB(A)
I	260	45
II	405	56
III	660	68

**OPTIONAL EXTRAS:**

Charcoal filter                   KITFC161  
Simple ducting kit               SP150  
Comprehensive ducting kit    SP150FLAT

## KSE91X-1

90CM CHIMNEY HOOD, ST/STEEL

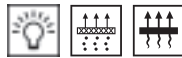

1 high performance motor, 115W  
3 speeds  
2 x 20W lights (front position)  
3 grease filters (dishwasher safe)  
Upper section glass aesthetic  
Internal re-circulation possible  
Vent outlet: ø 150mm  
Nominal power: 195W

Speed	Extraction rate IEC 61591 (m³/h)	Noise Level IEC 60704-2-13 dB(A)
I	240	44
II	340	52
III	437	54

**OPTIONAL EXTRAS:**

Charcoal filter                   KITD4C x 2  
Simple ducting kit               SP150  
Comprehensive ducting kit    SP150FLAT

**MODELS AVAILABLE**

90cm width                        KSE91X-1  
70cm width (2 filters)         KSE71X-1  
60cm width (2 filters)         KSE61X-1

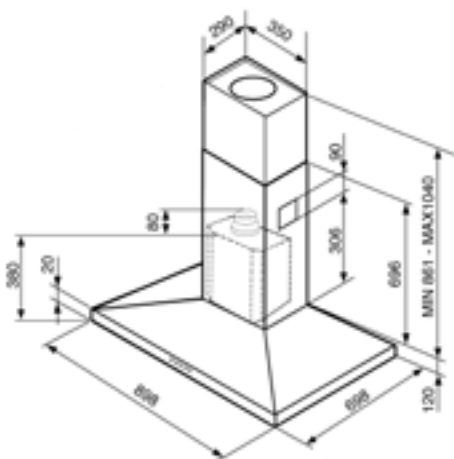

KSE71X-1  
70cm width (2 filters)



KSE61X-1  
60cm width (2 filters)

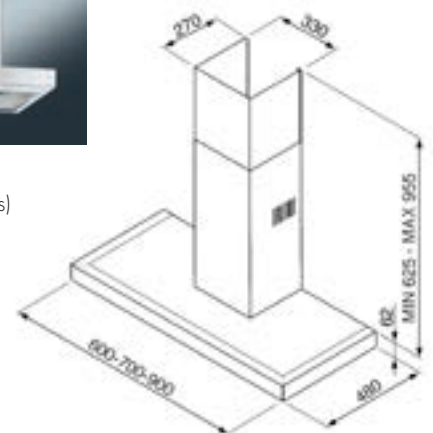

## HOODS



KSE91X-1

# HOODS

## KSED92X

90CM CHIMNEY HOOD, ST/STEEL



1 high performance motor, 195W  
3 speeds  
2 x 40W lights  
3 metal grease filters  
Internal re-circulation possible  
Vent outlet:  $\varnothing$  120mm  
Nominal power 275W

Speed	Extraction rate IEC 61591 (m <sup>3</sup> /h)	Noise Level IEC 60704-2-13 dB(A)
I	255	45
II	280	49
III	350	58

**OPTIONAL EXTRAS:**

Charcoal filter **FLT2**  
Simple ducting kit **SP215**  
Comprehensive ducting kit **SP217**

## KSED62X

60CM CHIMNEY HOOD, ST/STEEL

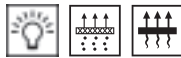

1 high performance motor, 195W  
3 speeds  
2 x 40W lights  
2 metal grease filters  
Internal re-circulation possible  
Vent outlet:  $\varnothing$  120mm  
Nominal power 275W

Speed	Extraction rate IEC 61591 (m <sup>3</sup> /h)	Noise Level IEC 60704-2-13 dB(A)
I	255	45
II	280	49
III	350	58

**OPTIONAL EXTRAS:**

Charcoal filter **FLT2**  
Simple ducting kit **SP215**  
Comprehensive ducting kit **SP217**

**MODELS AVAILABLE**

60cm width **KSED62X**  
70cm width **KSED72X**



**KSED72X**  
70cm width

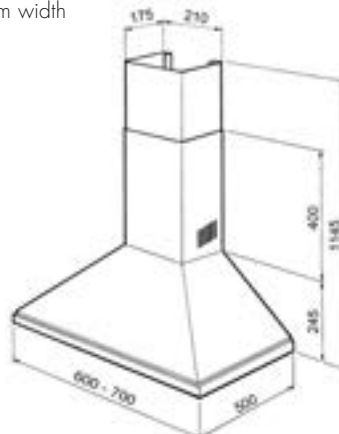
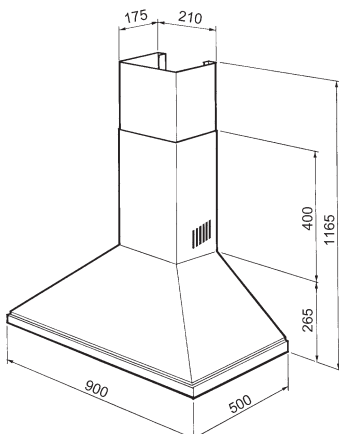

## KSET61

60CM TELESCOPIC HOOD, ST/STEEL EFFECT

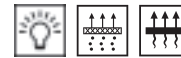

1 high performance motor, 160W  
2 speeds  
2 x 40W lights  
2 metal grease filters  
Internal recirculation possible  
Vent outlet  $\varnothing$  120mm  
Nominal power 240W

Speed	Extraction rate IEC 61591 (m <sup>3</sup> /h)	Noise Level IEC 60704-2-13 dB(A)
I	233	45
II	332	54

**OPTIONAL EXTRAS:**

Charcoal filters **KITC3C x 2**  
Simple ducting kit **SP215**  
Comprehensive ducting kit **SP217**

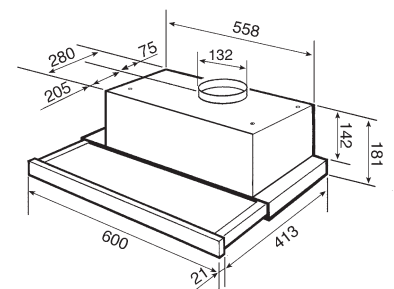

# HOODS

## KSEI62

60CM INTEGRATED HOOD, SILVER GREY



1 high performance motor, 150W  
3 speeds  
2 x 40W lights  
1 metal grease filter  
Internal re-circulation possible  
Vent outlet ø 120mm  
Nominal power 230W

Speed	Extraction rate IEC 61591 (m³/h)	Noise Level IEC 60704-2-13 dB(A)
I	135	54
II	175	61
III	270	65

**OPTIONAL EXTRAS:**

Charcoal filter                   KITFC31  
Simple ducting kit               SP215  
Comprehensive ducting kit    SP217

## KSEC61X

60CM STANDARD HOOD

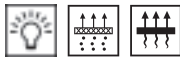

1 high performance motor, 125W  
3 speeds  
2 x 40W lights  
2 metal grease filters  
Internal re-circulation possible  
Vent outlet ø 120mm  
Nominal power 205W

Speed	Extraction rate IEC 61591 (m³/h)	Noise Level IEC 60704-2-13 dB(A)
I	116	39
II	142	43
III	240	56

**OPTIONAL EXTRAS:**

Charcoal filter                   KITC2R  
Simple ducting kit               SP215  
Comprehensive ducting kit    SP217

**MODELS AVAILABLE**

St/steel                               KSEC61X  
Black                                   KSEC61NE



**KSEC61NE**  
Black

## KI52-1

52CM CANOPY HOOD, SILVER GREY

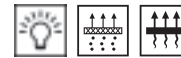

1 high performance motor, 125W  
3 speeds  
2 x 28W lights  
1 metal grease filter  
Internal re-circulation possible  
Vent outlet ø 150mm  
Nominal power 181W

Speed	Extraction rate IEC 61591 (m³/h)	Noise Level IEC 60704-2-13 dB(A)
I	165	51
II	225	56
III	300	63

**OPTIONAL EXTRAS:**

Charcoal filter                   KITFC155  
Simple ducting kit               SP150  
Comprehensive ducting kit    SP150FLAT

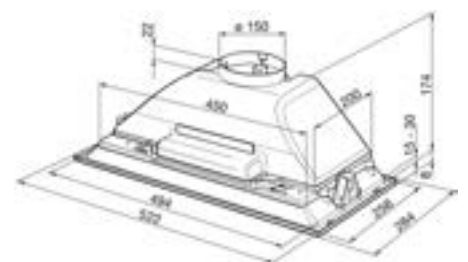
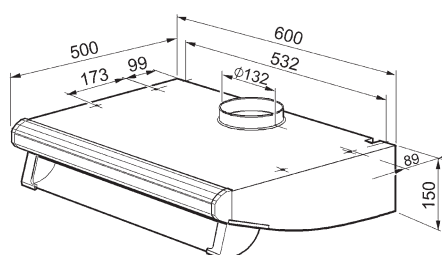
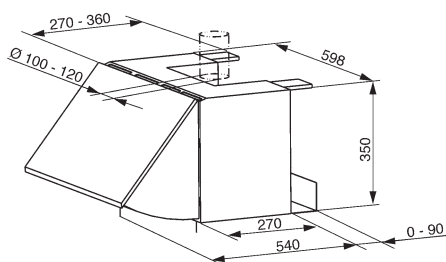

**SS55PTLH3**

AMERICAN SIDE BY SIDE REFRIGERATOR-FREEZER WITH SOFT-TOUCH HOME BAR, ST/STEEL EFFECT



Gross capacity: 600 litres  
 LCD display and soft-touch control panel  
 Ice and water dispenser  
 Internal water filter  
**Soft-touch home bar**  
 Holiday function  
 Child lock function  
 Noise level: 40 dB(A) RE 1 pW

REFRIGERATOR:  
 Fresh food capacity: 358 litres  
 "Extra Fresh" zone with soft-touch control  
 2 drawers with humidity control  
 4 glass shelves  
 Chrome wine rack  
 4 temperature sensors  
 Comprehensive door storage

FREEZER: **\*\*\*\***  
 Frozen food capacity: 173 litres  
**Completely frost free**  
 Fast freeze  
 2 drawers  
 4 glass shelves  
 4 temperature sensors  
 Comprehensive door storage

Energy efficiency class: A+  
 Energy consumption: 461 kW/h per year  
 Climatic class: N  
 Freezing capacity: 12kg/24h  
 Thaw time: 17 h

Nominal power: 0.9kW

**SS55PTE3**

AMERICAN SIDE BY SIDE REFRIGERATOR-FREEZER, ST/STEEL EFFECT



Gross capacity: 600 litres  
 LED display and soft-touch control panel  
 Ice and water dispenser  
 External water filter  
 Holiday function  
 Child lock function  
 Noise level: 40 dB(A) RE 1 pW

REFRIGERATOR:  
 Fresh food capacity: 365 litres  
 2 drawers with humidity control  
 4 glass shelves  
 Chrome wine rack  
 4 temperature sensors  
 Comprehensive door storage

FREEZER: **\*\*\*\***  
 Frozen food capacity: 173 litres  
**Completely frost free**  
 Fast freeze  
 2 drawers  
 4 glass shelves  
 4 temperature sensors  
 Comprehensive door storage

Energy efficiency class: A+  
 Energy consumption: 464 kW/h per year  
 Climatic class: N  
 Freezing capacity: 12kg/24h  
 Thaw time: 17 h

Nominal power: 0.9kW



SS55PTLH3

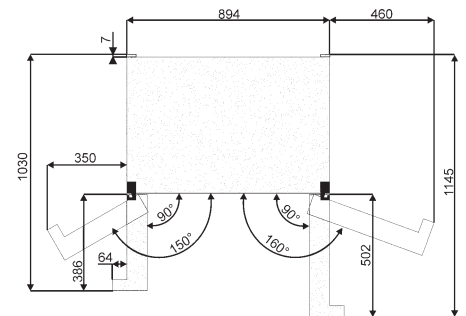

SS55PTLH3  
 SS55PTE3



# REFRIGERATION

## CR325P1

IN COLUMN COMBINED REFRIGERATOR & FREEZER



Gross capacity: 271 litres  
 Reversible doors  
 Sliding rail fitting  
 Electronic thermostat  
 Noise level: 37 dB(A) RE 1 pW

REFRIGERATOR  
 Fresh food capacity: 201 litres  
 Automatic defrost  
 Fan  
 4 adjustable glass shelves  
 Glass fruit and vegetable cover  
 2 fruit and vegetable containers  
 Comprehensive door storage

FREEZER **\*\*\*\***  
 Frozen food capacity: 72 litres  
 3 drawers

Energy efficiency class: A+  
 Energy consumption: 292 kW/h per year  
 Climatic class: SN-ST  
 Freezing capacity: 3.5kg/24h  
 Thaw time: 15 h

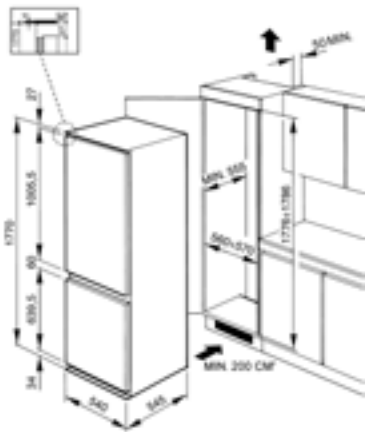

CR325P1

## CR5050AP

IN COLUMN COMBINED REFRIGERATOR & FREEZER



Gross capacity: 277 Litres  
 Reversible doors  
 Sliding rail fitting  
 Noise level: 39 dB(A) RE 1 pW

REFRIGERATOR  
 Fresh food capacity: 162 litres  
 3 adjustable glass shelves  
 Glass fruit and vegetable cover  
 2 fruit and vegetable containers  
 Comprehensive door storage

FREEZER **\*\*\*\***  
 Frozen food capacity: 95 litres  
 4 drawers  
 Ice cube tray

Energy efficiency class: A+  
 Energy consumption: 296 kW/h per year  
 Climatic class: SN-ST  
 Freezing capacity: 4.5kg/24h  
 Thaw time: 19 h

Nominal power: 1.4kW

Nominal Power: 1.4kW

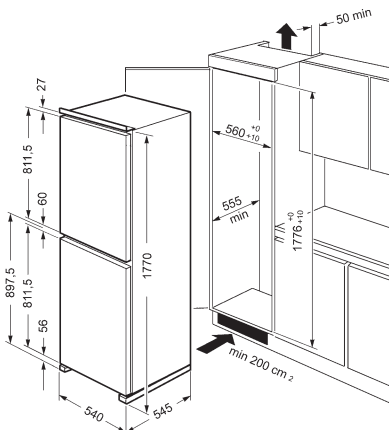

CR5050AP

## UKFL164AP

IN COLUMN LARDER REFRIGERATOR



Gross capacity: 146 litres  
Reversible door  
Noise level: 43 dB(A) RE 1 pW

REFRIGERATOR

Fresh food capacity: 145 litres  
Automatic defrost  
3 adjustable glass shelves  
1 fixed glass shelf  
2 fruit & vegetable containers  
Comprehensive door storage

Possible combination with UKV144AP1 freezer

Energy efficiency class: A+  
Energy consumption: 120 kW/h per year  
Climatic class: ST  
Nominal power: 0.50kW

## UKFL167AP

IN COLUMN REFRIGERATOR WITH ICE-BOX



Gross capacity: 131 litres  
Reversible door  
Noise level: 42 dB(A) RE 1 pW

REFRIGERATOR

Fresh food capacity: 114 litres  
Automatic defrost  
2 adjustable glass shelves  
1 fixed glass shelf  
2 vegetable containers  
Comprehensive door storage

FREEZER **\*\*\*\***

Frozen food capacity: 17 litres  
Ice cube tray

Energy efficiency class: A+  
Energy consumption: 175 kW/h per year  
Climatic class: ST  
Freezing capacity: 2kg/24h  
Thaw time: 12h  
Nominal power: 0.80kW

## UKV144AP1

IN COLUMN FREEZER

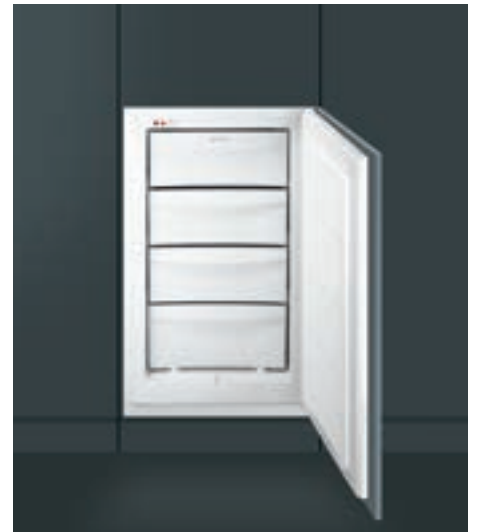

Gross capacity: 103 litres  
Reversible door  
Noise level: 40 dB(A) RE 1 pW

FREEZER **\*\*\*\***

Frozen food capacity: 86 litres  
4 drawers  
Fast freezing function and button  
Acoustic alarm

Possible combination with UKFL164AP larder Refrigerator

Energy efficiency class: A+  
Energy consumption: 196 kW/h per year  
Climatic class: N-ST  
Freezing capacity: 11kg/24h  
Thaw time: 15h  
Nominal power: 0.80kW

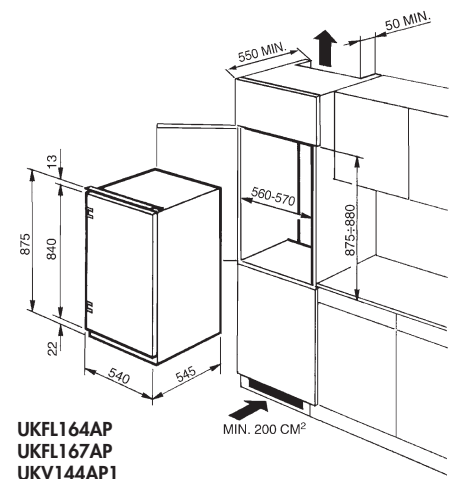

# REFRIGERATION

## LF1700PC

UNDERWORKTOP LARDER REFRIGERATOR



Gross capacity: 144 litres  
Reversible door  
Noise level: 40 dB(A) RE 1 pW

REFRIGERATOR

Fresh food capacity: 143 litres  
Automatic defrost  
3 adjustable glass shelves  
Fruit and vegetable compartment  
Further door storage

Energy efficiency class: A+  
Energy consumption: 123 kW/h per year  
Climatic class: SN-ST  
Nominal power: 0.70kW

## FR1650PC

UNDERWORKTOP FREEZER



Gross capacity: 96 litres  
Reversible door  
Noise level: 41 dB(A) RE 1 pW

FREEZER **\*\*\*\***

Frozen food capacity: 86 litres  
3 Storage drawers  
Fast freezing function

Energy efficiency class: A+  
Energy consumption: 186 kW/h per year  
Climatic class: SN-ST  
Freezing capacity: 8kg/24h  
Thaw time: 17 hours  
Nominal power: 0.90kW

## RF1500PC

UNDERWORKTOP REFRIGERATOR WITH ICE-BOX



Gross capacity: 130 litres  
Reversible door  
Noise level: 41 dB(A) RE 1 pW

REFRIGERATOR

Fresh food capacity: 105 litres  
Automatic defrost  
2 adjustable glass shelves  
Fruit and vegetable storage compartment

FREEZER **\*\*\*\***

Frozen food capacity: 21 litres  
Ice cube tray

Energy efficiency class: A+  
Energy consumption: 189kW/h per year  
Climatic class: N-ST  
Nominal power: 0.80kW

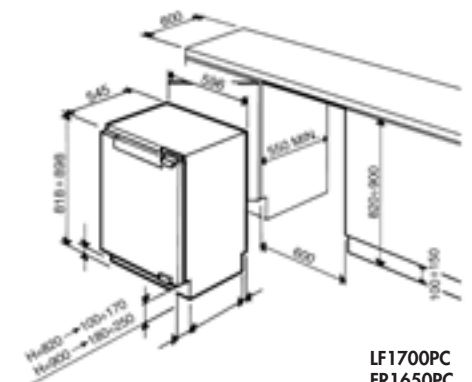

LF1700PC  
FR1650PC  
RF1500PC



# DISHWASHERS

## D1607C

60CM FULLY INTEGRATED HORIZONTAL DISHWASHER



MODEL FEATURES:



PROGRAMME & OPTIONS:



7 place settings  
 10 programmes: Soak, Plate warming, Quick, Crystal, Auto 40° - 50°C, ECO, Normal, Auto 60° - 70°C, Strong & Fast, Super  
 5 temperatures (38° 45° 55° 65° 70°)  
 Consumption (based on 280 cycles):  
 Water: 2800 litres per annum  
 Energy: 211 kWh per annum  
 Noise level: 46 dB (A) RE 1 pW

5 Buttons:  
 On/Off  
 Programme selection  
 Option for FlexiTabs  
 Delay Timer 9h  
 Additional programmes

Lights:  
 Salt  
 Rinse aid

Orbital spray system  
 Total Acquastop  
 Concealed heating element  
 Maximum plate diameter: 32cm  
 Average wash time approximately 100 mins  
 Adjustable water softener  
 Self balancing door hinges  
 Graphite basket with anti-drip device  
 St/steel filter

Energy efficiency: A  
 Drying performance: A  
 Nominal power: 1.9kW

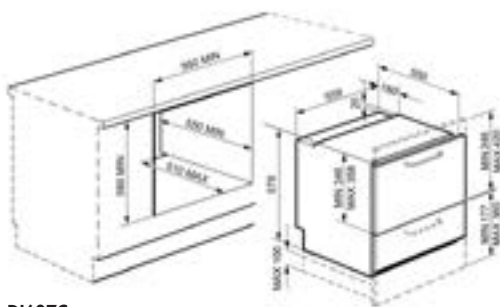

D1607C

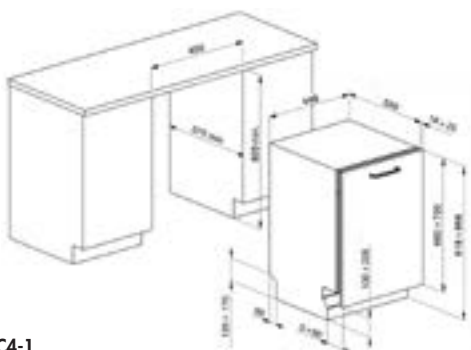

DIC4-1

## DIC4-1

45CM FULLY INTEGRATED DISHWASHER



MODEL FEATURES:



PROGRAMME & OPTIONS:



10 place settings  
 5 programmes: Soak, Rapid 27min, ECO, Normal, Super  
 4 temperatures (45° 50° 65° 70°)  
 Consumption (based on 280 cycles):  
 Water: 2660 litres per annum  
 Energy: 236 kWh per annum  
 Noise level: 46 dB (A) RE 1 pW

2 Buttons:  
 On/Off  
 Programme selection

Lights:  
 Salt  
 Rinse aid

SwingWash spray system  
 Partial Acquastop with double hose  
 Concealed heating elements  
 Maximum plate diameter: 30cm  
 Average wash time approximately 100 mins  
 Adjustable water softener  
 Self balancing door hinges  
 Graphite baskets  
 St/steel filter

Rear levelling foot adjustable from the front

Energy efficiency: A+  
 Drying performance: A  
 Nominal power: 1.4kW

Maximum furniture door weight 7.5kg  
 Minimum furniture door weight 2.5kg

**WDF12C7-1**

60CM FREESTANDING WASHER/DRYER, WHITE



FEATURES



SPECIAL PROGRAMMES



Electronic display includes 24h delay timer  
 6 buttons: Start/pause, drying, confirm options, options selector, spin speed selector, temperature selector  
 On/off & programme control  
 Door opening release

Electronic display shows programme selected and progression

15 washing programmes including  
 Special programmes; mix, shirts, gym, night, softener and **super fast 15 min.**  
 Customised options; variable temperature, spin speed, option selector, and FlexiTime  
 2 drying programmes  
 Variable spin speed up to 1200rpm  
 Clean programme

**Max washing capacity: 7Kg dry laundry**  
**Max drying capacity: 4Kg**  
 Condenser drying  
 St/steel drum and polypropylene tank  
 Self clean detergent drawer  
 Extra large 300mm porthole  
 Automatic variable load

Consumption (per cycle):  
 For washing only: water: 47 litres, energy: 1.19kW/h  
 For complete 7Kg wash + 2 sessions of 4Kg drying: water: 103 litres, energy: 5.44kW/h  
 Nominal power: 2.00kW

Energy efficiency class: B  
 Washing performance: A

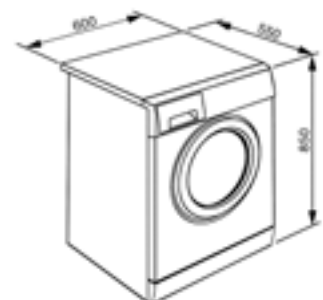

**WDI12C7**

60CM FULLY INTEGRATED WASHER/DRYER



FEATURES



SPECIAL PROGRAMMES



Electronic display includes 24h delay timer  
6 buttons: Start/pause, drying, delay timer, confirm options, options selector, spin speed selector  
On/off & programme control  
Door opening release

Electronic display shows programme selected and progression

12 washing programmes including Special programmes; mixed fabrics, super fast 15 min.  
Customised options; variable temperature, spin speed, and option selector  
2 drying programmes  
Variable spin speed up to 1200rpm  
Clean programme  
**Max washing capacity: 7Kg dry laundry**  
**Max drying capacity: 4Kg**  
Condenser drying  
St/steel drum and polypropylene tank  
Self clean detergent drawer  
Extra large 300mm porthole  
Automatic variable load  
Total Acquistop

Consumption (per cycle):  
For washing only: water: 47 litres, energy: 1.19kW/h  
For complete 7Kg wash + 2 sessions of 4Kg drying: Water 103 litres, energy: 5.44kW/h  
Nominal power: 2.00kW

Energy efficiency class: B  
Washing performance: A

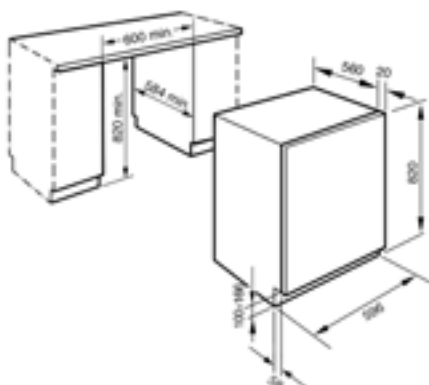

**WMI12C7**

60CM FULLY INTEGRATED WASHING MACHINE



FEATURES



SPECIAL PROGRAMMES



Electronic display includes 24h delay timer  
6 buttons: start/pause, child lock, delay timer, confirm options, option selector, spin speed On/off & Programme control  
Door opening release

Electronic display shows programme selected and progression

15 washing programmes including Special programmes; mixed 30°C and super fast 15 min  
Customised options; variable temperature, spin speed, and option Selector  
Variable spin speed up to 1200rpm  
**Max 7Kg of dry laundry**  
St/steel drum and polypropylene tank  
Self clean detergent drawer  
Extra large 300mm porthole  
Automatic variable load  
Total Acquistop

Consumption (based on 220 cycles)  
Water: 10340 litres/ per annum  
Energy: 218kWh/ per annum  
Noise level washing phase: 56 dB(A) RE 1 pW  
Noise level spinning phase: 70 dB(A) RE 1 pW  
Nominal power: 2.00kW

Energy efficiency class: A+  
Spin drying performance: B

# SINKS

## CUR150

1.5 BOWL SINGLE DRAINER REVERSIBLE ST/STEEL INSET SINK



1.5 bowl single drainer inset sink  
 Bowl depth: 1x190mm 1x130mm  
 Bowl width: 1x340mm 1x 165mm  
 Drain: 2x3.5"

STANDARD ACCESSORIES:  
 Overflow  
 Drain  
 Gaskets  
 Fixing Clips  
 Dishwasher Drain Tap

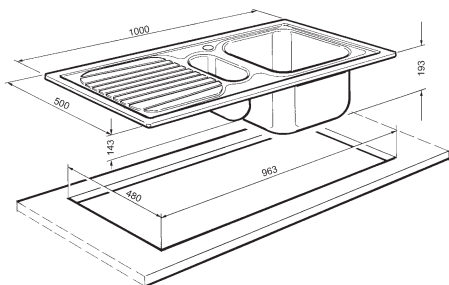

## CUR100

SINGLE BOWL SINGLE DRAINER REVERSIBLE ST/STEEL INSET SINK



Single bowl single drainer inset sink  
 Bowl depth: 1x190mm  
 Bowl width: 1x340mm  
 Drain: 2x3.5"

STANDARD ACCESSORIES:  
 Overflow  
 Drain  
 Gaskets  
 Fixing Clips  
 Dishwasher Drain Tap

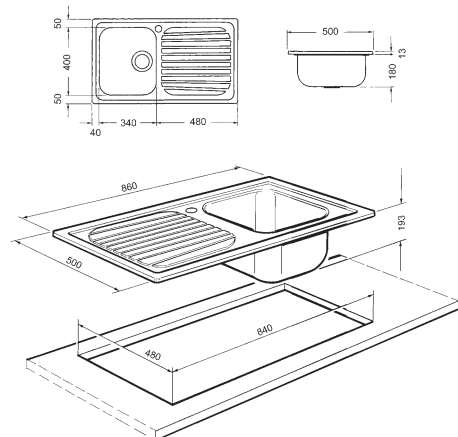

# TAPS

## PALERMO

SINGLE LEVER MIXER TAP



Single lever mixer  
Chrome finish  
Swivel spout  
Aerator  
Ceramic disc cartridge  
Braided stainless steel connection hoses  
Minimum water pressure 0.5 bar

## RIMINI-2

DUAL FLOW MIXER TAP



Dual flow mixer  
Chrome finish  
Swivel spout  
Spout with anti-splash  
Quarter turn ceramic disc valve  
Copper connection tails  
Minimum water pressure 0.5 bar

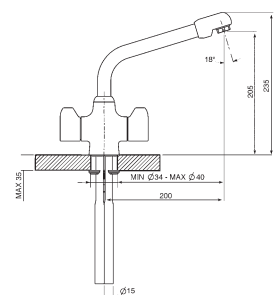
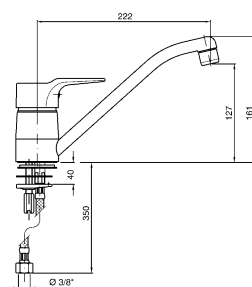

## Quality, Environmental and Occupational Health & Safety Management Systems

All Smeg factories are ISO9001, ISO14001 and OHSAS 18001 certified, ensuring that the highest standards of quality are continually maintained whilst actively responding to all environmental issues relating to manufacture. The materials and components used to produce smeg products undergo strict quality control testing, and care is taken to source recyclable materials wherever possible. These management systems enable Smeg to provide complete assurance that all products meet superior standards whilst respecting the environment. The workforce is not forgotten – the occupational health and safety assessment scheme promotes a safe and healthy working environment, aids legislative compliance and helps improve overall performance.



UNI EN ISO 9001



UNI EN ISO 14001



OHSAS 18001

Whereas every effort has been made to ensure that the information contained in our literature is correct at time of going to print, this brochure should not be regarded as an infallible guide to current specification, nor does it constitute an offer for sale of any particular product.



This catalogue is printed entirely on FSC® (Forest Stewardship Council®) certified paper that has been produced with cellulose sourced from forests that are managed responsibly, in accordance with rigorous environmental, social, economic and cultural standards.  
<http://www.fsc.org/>

# COOKING FUNCTIONS

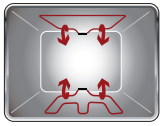

**UPPER AND LOWER ELEMENT ONLY:**

A traditional cooking method best suited for single items located in the centre of the oven. The top of the oven will always be hottest. Ideal for roast, fruit cakes, bread etc.

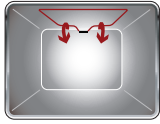

**LOWER HEATING ELEMENT ONLY:**

Ideal for foods that require extra base temperature without browning, e.g. pastry dishes, pizza. Also suitable for slow cooking of stews and casseroles.

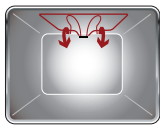

**GRILL ELEMENT / HALF GRILL:**

For rapid cooking and browning of foods.

Best results can be obtained by using the top shelf for small items, the lower shelves for larger ones, such as chops or sausages. For half grill heat is generated only at the centre of the element, so is ideal for smaller quantities.

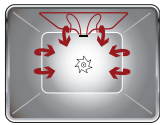

**FAN WITH GRILL ELEMENT:**

The fan reduces the fierce heat from the grill, providing an excellent method of grilling

various foods, chops, steaks, sausages etc. giving even browning and heat distribution, without drying out the food. The top two levels recommended for use, and the lower part of the oven can be used to keep items warm at the same time, an excellent facility when cooking a grilled breakfast. Half grill (centre portion only) is ideal for small quantities of food.



**MICROWAVE:**

Penetrating straight into the food, microwaves cook very quickly and with considerable energy savings. Suitable for cooking without fat, they are also able to thaw and heat food without altering its original appearance and aroma. The microwave function can also be combined with conventional functions with all the resulting advantages. Ideal for all types of food.

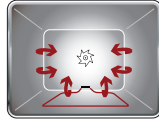

**FAN WITH LOWER ELEMENT:**

This combination completes cooking more quickly of foods that are ready on the surface, but require more cooking inside, without further browning.

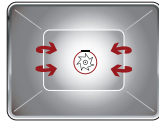

**CIRCLAIRE:**

The combination of the fan and circular element around it gives a hot air cooking method. This provides many benefits including no preheat if cook time is more than 20 minutes, no flavour transfer when cooking different foods at the same time, less energy, and shorter cook times. Good for all types of food.



**CIRCLAIRE WITH UPPER AND LOWER ELEMENTS:**

The use of the fan with both elements allows food to be cooked quickly and effectively, ideal for large joints that require thorough cooking. It offers a similar result to rotisserie, moving the heat around the food, instead of moving the food itself, enabling any size or shape to be cooked.

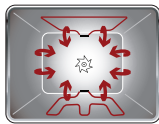

**FAN WITH UPPER AND LOWER ELEMENTS:**

The elements combined with the fan aim to provide more uniform heat, a similar method to conventional cooking, so pre-heat is required. Most suitable for items requiring slow cooking methods.



**MICROWAVE + GRILL ELEMENT:**

To achieve a combined cooking with grill that cooks the outside whilst assuring an internal cooking thanks to the microwave function.

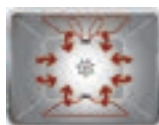

**PIZZA FUNCTION:**

The simultaneous operation of these three elements ensures an optimum cooking facility when used with the Smeg pizza stone.

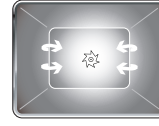

**DEFROST:**

Both symbols refer to the same function.

The circulation of air enables quicker thawing of frozen food, without the use of any heat. Ideal for use prior to cooking of ready-made dishes, or cream filled products etc.



**FAN:**

As above but with thermostat set a '0'.



**SNOWFLAKE:**

With the switch on this symbol, no heating is possible even if the thermostat is turned.



**ECO:**

The combination of the grill, fan and lower element is particularly suitable for cooking small quantities of food.



**PYROLITIC CLEANING:**

Pyrolytic cleaning at 500°C destroys all the dirt deposits inside the oven. The Eco pyrolytic cleaning function can be selected when the oven has a lighter build up of dirt. This function has a maximum duration of 1.5 hours.



**VAPOR CLEAN**

The Vapor Clean function makes cleaning simple, by using steam generated using a customised programme.



**DEFROST BY TIME:**

The circulation of air enables quicker thawing of frozen food, without the use of any heat. The microwaves power will be automatically varied to achieve the best thawing results.



**DEFROST BY WEIGHT:**

The circulation of air enables quicker thawing of frozen food, without the use of any heat. The defrosting time will be calculated based on the food's type and weight and the microwaves power will be automatically varied to achieve the best thawing results.

# SYMBOLS

## GENERAL



Product **energy rating**, measured from A+++ to D / G depending on the product family.



Appliances with this symbol can reduce energy consumption by a further 10% - 20% from the standard A energy rating.



**Finger-friendly stainless steel** finish keeps stainless steel looking as good as new.



**Child lock**, some models are fitted with a device to lock the programme/cycle so it cannot be accidentally changed.



**Eco-logic** option allows you to restrict the power limit of the appliance real energy saving.

## OVENS



The **capacity** indicates the amount of usable space in the oven cavity in litres.



Smeg ovens incorporate **safe cook**, the system for closed door grilling to keep cooking smells inside the oven and ensure a safe cooking environment.



The **rapid preheat** function can be used to reach the selected temperature in just a few minutes.



All Pyrolytic ovens have a **cooler touch door** which allows the outer glass door to become no hotter than 55°C.



The oven cavity has a **number different cooking levels** for maximum flexibility.



The **inner door glass** can be removed with a few quick movements for cleaning.



**Microwave energy** shortens cooking times drastically and produced notable energy savings.



**Air cooling system** to ensure a safe surface temperatures.



The **enamel interior** of all Smeg ovens have a special antacid lining which helps keep the interior clean by reducing the amount of cooking grease adhering to it.



**Quadruple glazed** doors keep surface temperatures as low as possible and are featured on all Pyrolytic ovens.



**Triple glazed** and **double glazed doors** are featured on several Smeg appliances.



A simple **13 amp supply** is required to connect any Smeg single pyrolytic oven.



**Combination microwave** ovens can be used either as a microwave, or as a traditional oven, or alternatively the two methods can be combined.



**All glass inner door**, a single flat surface which is simple to keep clean.



The complete base of the microwave can be used for cooking, so no turntable is required.

## HOBS



**Heavy duty cast iron pan stands** for maximum stability and strength.



All ceramic hobs have a **timer** which automatically ends cooking after a preset time.



**Time elapsed** shows how long the cooking zone has been in use



Powerful **ultra rapid burners** offer up to 5kw of power.



**Power booster** option allows the zone to work at full power when very intense cooking is necessary.



Easy to use **touch controls** allow the appliance to be programmed at the touch of a button.

## COOKER HOODS



Extracting through **charcoal filters** or directly to the exterior lessens strong cooking odours considerably.



Model has **filters** to help remove grease from the steam emanating from the pans during cooking.



All cooker hoods feature **lights** to illuminate the cooking area or add to the ambience of the kitchen.

## REFRIGERATION



The **fast freezing** function brings the temperature of the compartment down when activated a few hours prior to usage.



**LED interior lighting** is a more energy efficient and long lasting way of illuminating the interior of the appliance.



The **Frost free** system prevent ice from forming so that no defrosting is required.



The **automatic defrost** system works by automatically defrosting at regular intervals eradicating the need to defrost altogether.





The **power saving mode** allows you to disable the refrigerator and keep the freezer working.

## SYMBOLS



### DISHWASHERS

 **Orbital wash system** distributes water evenly throughout the 60cm dishwasher cavity, directing water with precision to ensure an excellent wash.

 The **SwingWash system** ensures optimum water distribution throughout 45cm dishwasher tanks to deliver excellent wash results.

  The **auto programme** regulates the length of a cycle depending on the need for a pre-wash and the number of rinses required.

 The **rapid 27 mins quick programme** takes just 27 minutes to wash a load at 38° C, suitable for lightly soiled dishes.

   The symbols show the **number of plate settings** of the dishwasher.

 The **normal programme** is suitable for normal degrees of dirt for everyday use.

 Dish warming, this cycle is for clean dishes that provides a final hot rinse to make it possible for the dishes to be dried and then used immediately for serving hot food.

 The **soak programme** provides a rinse to prevent dirt from drying.

 The **quick time** option can reduce the length of the wash cycle up to 55%.

 The **crystal cycle** is designed especially for delicate dishes with light dirt.

 The **Strong & Fast** programme takes less than 1 hour to eliminate the most stubborn dirt and dried on residues.

 **Total acquastop** is an electronic device which monitors water levels in the machine to detect leaks in the hose and switch off the water supply immediately if necessary.

 The **super programme** is suitable for removing stubborn dirt.

 The **1/2 load** allows you to wash a reduced load saving energy, water and time.

 The **Ultraclean** programme performs a final 10 minute rinse at a high temperature of 70C eliminating virtually all bacteria.

 **Eco**, this economic wash programme uses a low amount of water and energy in order to provide the most environmentally friendly cleaning option.

### LAUNDRY

 The **FlexiTime** option allows the user to reduce the time of the cycle selected, providing extra flexibility and control.

 **Super fast 15 min**: a programme designed to wash small amounts of laundry fast, ideal for washing lightly soiled garments.

 A **cleaning programme** has been created to maintain the performance of washer/dryers. The display shows automatically when cleaning is required.

 Drum has maximum capacity of **7kg of dry laundry**.

 **Delay timer**, can be set to run the programme at a convenient time or to take advantage of off-peak energy periods.

 **Shirts**, a cycle to wash shirts in a short time with the utmost care, using a delicate spin for easy ironing.

 **Hand wash**, this specific programme for delicate fabrics uses slower rotations of the drum to ensure the utmost care for clothing.

 Prewash adds a stage before the main wash, useful for washing heavily soiled garments.

 **Intensive**, during this cycle the maximum temperature reaches 60°C in the extended washing stage, providing an intensive clean.

 **Wool**, this cycle is designed for delicate wool items with light or normal soiling suitable for machine washing.

 **Easy Iron**, this is an option which can be selected to ensure the finished laundry is left with less creases to make ironing easier.

 **Night**: an ideal programme for those who want to take advantage of off-peak energy periods, this cycle is particularly quiet due to slower rotations of the drum.

 The **Extra rinse** option: can be added to the selected programme when more thorough cleansing of special fabrics is needed.

 **LCD display**, to show programmes, functions and options selected and the time to the end of the cycle.

 **Total acquastop**, the product is built with 3 levels of anti-flood devices to ensure protection against water leakage.

 **Gym**, a cycle designed for washing lightly soiled garments, ie sports wear, this is a fast wash which is also kind to fabrics.

 **Mixed fabrics**, this cycle is designed for lightly soiled laundry in a mix of cottons and synthetics, or can be used just to refresh stored items.

 **Delicates**, this cycle is designed for delicate items with light or normal dirt by using a gentle wash programme.

 **Synthetic**, this cycle is designed for mixed synthetic items with light or normal dirt to be washed together at the same time.



**Smeg (UK) Limited**

3A Park Square, Milton Park, Abingdon  
Oxon OX14 4RN  
[www.smeguk.com](http://www.smeguk.com)

**Information line**

Tel. 0844 5579907 Fax. 0844 5579337

**Trade enquiries**

Tel. 0844 5570070 Fax. 0844 5574355

**Service & Spare Parts**

Tel. 0844 5579907 Fax. 0844 5579336